

# INSTALLATION GUIDE

ENG

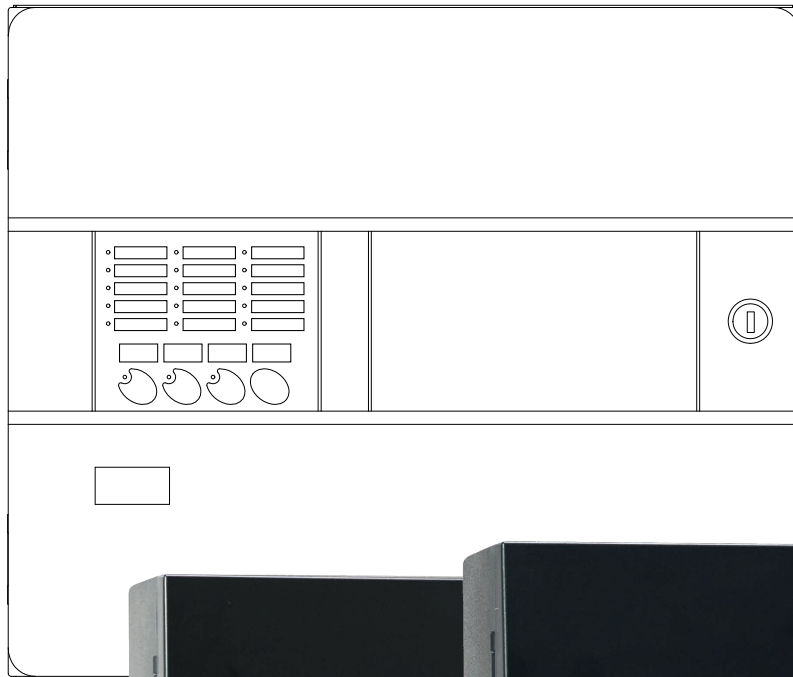





## Revision control

Revision	Comment	Date
a	First edition	29/11/2019
b	Typographical errors and regulatory references	05/12/2019
c	Specification table corrections and graphical corrections	16/12/2019
d	Lay out remake and revision	16/06/2020



## Conditions of use

Before installing the CAD-250 control panel, you must check that a series of criteria are met.

If these criteria are not met, the control panel may be damaged, problems may arise during system start-up or the functioning of the system may be adversely affected.

The CAD-250 control panel is certified to work under certain conditions; exceeding the working ranges of the control panel or inadequate conditions can lead to the warranty being voided.

# CONTENTS

ENG

<b>1. INTRODUCTION</b> .....	8
1.1. ABOUT THIS MANUAL.....	8
1.3. DISCLAIMER.....	8
1.3. STANDARDS AND COMPLIANCE.....	5
1.4. ADDITIONAL INDICATIONS.....	9
1.5. GENERAL SAFETY WARNINGS .....	9
1.6. REQUIRED DOCUMENTATION AND DESIGN.....	10
1.7. EXPLICIT DEFINITIONS .....	10
1.8. MAIN FEATURES OF THE CONTROL PANEL.....	11
1.9. ARCHITECTURE .....	11
1.10. INSPECTION.....	14
1.11. REQUIREMENTS .....	15
1.11.1. Assembly notes.....	15
1.11.2. Installation notes .....	15
1.11.3. Detection loop wiring.....	15
<b>2. ASSEMBLY GUIDE</b> .....	16
2.1. CABLE ENTRIES.....	16
2.2. ATTACHMENT .....	18
<b>3. CONNECTION GUIDE</b> .....	20
3.1. INTERNAL PARTS.....	20
3.2. INSERTABLE LANGUAGE CARD.....	22
3.3. MAIN BOARD PROTECTION.....	23
3.4. MAIN BOARD .....	24
3.5. CONNECTING TO THE MAINS .....	26
3.6. CONNECTING THE BATTERIES .....	27
3.7. LOOP CARDS .....	28
3.8. ADDRESSABLE LOOPS .....	30
3.8.1 Loop continuity.....	31
3.8.2 Connecting devices .....	31
3.8.3 Addressable loop .....	32
3.8.4 Loop check .....	33

3.9. SOUNDER OUTPUT .....	34	6. MAINTENANCE .....	58
3.9.1. Cancelling sounder outputs .....	34	6.1. LOG .....	58
3.9.2. Checking the sounder line .....	34	6.2. PERIODIC TESTS .....	58
3.9.3. Polarised sounder connection .....	35	6.2.1. Test Mode .....	58
3.9.4. NON-polarised sounder connection.....	35	6.3. CLEANING.....	59
3.10. 24 V AUXILIARY OUTPUT .....	36	<b>7. TROUBLESHOOTING .....</b>	<b>60</b>
3.11. CONNECTING TO THE FAULT RELAY.....	36	7.1. PRIMARY CONTROLS.....	60
3.12. CONNECTING TO THE ALARM RELAY .....	36	7.2. EVENTS SCREEN.....	62
3.13. FINAL CONNECTION CHECKS.....	37	<b>8. TECHNICAL SPECIFICATIONS .....</b>	<b>66</b>
3.14. COMMUNICATIONS CARD (OPTIONAL).....	37	<b>ANNEX 1: TOTEM INSTALLATION.....</b>	<b>68</b>
<b>4. START-UP .....</b>	<b>42</b>	<b>ANNEX 2: COMPATIBLE DEVICES and CONSUMPTION.....</b>	<b>76</b>
4.1. MAIN PANEL.....	42	<b>ANNEX 3: AUTONOMY AND LOOP CALCULATION .....</b>	<b>79</b>
4.2. GENERAL LEDS.....	42		
4.3. PRIMARY CONTROLS.....	43		
4.4. INITIAL START-UP.....	43		
<b>5. QUICK CONTROL PANEL CONFIGURATION.....</b>	<b>44</b>		
5.1. ADMINISTRATOR ACCESS .....	44		
5.2. ADMINISTRATOR SCREEN.....	45		
5.3. CONFIGURATION .....	46		
5.3.1. Control panel description .....	46		
5.3.2. Contact phone .....	46		
5.3.3. Installer information .....	46		
5.3.4. Date selection.....	46		
5.4. LOOP AUTOSEARCH .....	47		
5.5. DEVICES .....	48		
5.5.1. Information and configuration of the devices.....	49		
5.6. SECTORISATION.....	50		
5.7. MANOEUVRES .....	52		
5.8. SOFTWARE UPDATE .....	55		
5.9. PANEL TEST.....	56		
5.10. ETHERNET PORT CONFIGURATION.....	57		

# 1. INTRODUCTION

## 1.1. ABOUT THIS MANUAL

The purpose of this manual is to provide the user with all of the descriptions regarding procedures and technical details necessary to carry out the assembly, connection and start-up of CAD-250 fire alarm control panels.

For each step in the assembly, connection and start-up process of the CAD-250 control panel, a detailed description with drawings, diagrams and graphics are included, which will make it easier for these instructions to be understood.

The accuracy of the contents of this manual is the most important aspect and on which all efforts have been focused; nevertheless, the manufacturer reserves the right to change the information without prior notice.

## 1.2. DISCLAIMER

The manufacturer or distributors of this range of fire alarm panels cannot accept any responsibility for any misinterpretation of an instruction or guidance note or for full system compliance.

The manufacturer's policy is of continuous improvement and we reserve the right to make changes to the product specifications at our discretion and without prior notice.

Incorrect assembly, improper installation, poor configuration of the unit or the state of the detection wiring are not the responsibility of the control panel manufacturer.



**STORE THIS MANUAL.** It contains important instructions regarding installation and use. It is possible that you may need to consult it in the future.

**KEEP THE BOX.** It contains a printed template to facilitate assembly. You may need the packaging to send the control panel to the technical service or to move the unit to another location.

## 1.3. STANDARDS AND COMPLIANCE



The distinctive CE on this control panel indicates its compliance with the applicable directives and regulations of the European Community.

Directive	Standard	Description
2014/30/EU		Electromagnetic Compatibility Directive
2014/35/EU		Low Voltage Directive
305/2011/EU		Construction Products Directive
	EN54-2	Fire detection and fire alarm systems.
	EN54-4	Power supply equipment

## 1.4. ADDITIONAL INDICATIONS



**2011/65/EU (RoHS 2)**, European standard on the restriction of the use of certain harmful substances (lead, mercury, cadmium, hexavalent chromium, polybrominated biphenyls, polybrominated diphenyl ethers) in small and large household appliances, computer and telecommunications equipment, consumer electronic devices, lighting fixtures, electrical and electronic tools, toys, leisure and sports equipment, medical devices, control and surveillance instruments, including industrial control instruments, vending machines and other equipment not included in the previous categories.



**2012/19/EU (WEEE)**, European standard on the recycling of non-disposable products, such as unclassified municipal waste within the area of the European Union. When purchasing an equivalent new unit, return this product to your local supplier or dispose of it at the collection points designated for this purpose in order to facilitate its appropriate recycling.



## 1.5. GENERAL SAFETY WARNINGS

**ONLY STAFF THAT ARE DULY QUALIFIED MUST INSTALL OR CONFIGURE THIS UNIT.**



Read this manual carefully before beginning to install the panel.

**MAKE SURE** you have the appropriate tools

Not paying attention to this warning may cause irreversible damage to the unit, the facility to malfunction or safety risks for people.

If you have any queries regarding the assembly, installation or configuration of the control panel, please contact your normal distributor or customer service before continuing to install the unit.



The installation must be carried out in accordance with the applicable standards issued by the competent authority of the corresponding country. Consult local, national and business standards

Do not use the panel or its components beyond their performance specifications



The ambient operating temperature must be within the range of -5°C to 40°C



The relative humidity must be within the range of 5% and 95% without condensation

The control panel must always be connected to a protective earth.



The installation of the system on CAD-250 control panels must include a method to isolate or disconnect the input voltage supply. The isolation or disconnection device must be located close to the system and be clearly labelled. The isolation or disconnection device must disconnect both the active and the neutral pole, but without losing continuity to earth.

Consider the incorporation of protection for the inputs against overvoltages, depending on the type of location and risk expected.

All signal and interconnection cables must be armoured and the mesh must only be connected at the points specified by this manual.

All ducts and the cable protection must be connected to the protective earth, trying to avoid earth loops and contact with the cable shield.

The access doors and entry points must be kept closed when the system is connected in normal operation.

## 1.6. REQUIRED DOCUMENTATION AND DESIGN

For the correct and complete installation, start-up, installation and maintenance, consult the following information and the annexes they reference:

Document	Description
MC 383 en 2020	Advanced configuration guide for the CAD-250 control panel
MU 379 en 2020	CAD-250 control panel User Manual
MS 419 en 2020	CAD-250 PC software for panel set up

As required, the procedures will be shown in one or more diagrams, depending on the complexity of the task.

Check that the manual version corresponds to the unit you are going to install.

Detnov pays special attention to the compatibility of the components and the integrity of the system components in the long term; however, check any compatibility notes between versions to ensure the greatest reliability and the best user experience.

The features, specifications and information related to the product described in this manual refer to the date of this document (on the cover) and may be modified due to system design, installation and configuration regulations and standards.

The most up-to-date information and the approvals for this are available on our website [www.DETNOV.com](http://www.DETNOV.com).

This guide does not describe the advanced features related to the configuration or operation of the control panel, as they are included in other manuals.







## 1.7. EXPLICIT DEFINITIONS

The procedures described in this manual include warnings and cautions to advise the user to adopt methodical and safe working practices during installation, start-up and configuration.

Please follow the warnings in this manual, as misuse or improper installation may result in incorrect assembly or even death.

These warnings alert you to serious fire and electrocution risks (areas with an electrical risk that exceeds the safety level), the risk of damage to elements of the control panel that are sensitive to static current or short circuits if the procedures, recommendations, regulatory references or advice for facilitating the assembly, connection or installation processes are not followed.

The definitions are classified according to the following levels:

Word	Definition
 <b>WARNING!</b>	Risk of personal injury
	Risk for the product and system
	Check according to the applicable regulations
	There is no risk and no observations or comments to facilitate the action
	Go to the technical support service
	Recommended action
	Action not recommended or incorrect











## 1.8. MAIN FEATURES OF THE CONTROL PANEL

The **CAD-250** is an addressable control panel with advanced configuration and functional features, designed to work with **DETNOV** addressable sensors, modules and addressable buttons. Its modular design provides the user with an extremely powerful and completely flexible system.

### Basic configuration (single panel):

**10" TFT COLOUR SCREEN** (1024 x 600 pixels). The colour touchscreen allows the user to interact easily with the control panel.

**USER-FRIENDLY MULTILINGUAL INTERFACE.** The graphical interface was designed for intuitive and user-friendly browsing and allows important information to be identified quickly in each case, such as alarms or events.

-  **2** sounder outputs.
-  **1** alarm output.
-  **1** fault output.
-  **8** loops and **2000** devices (250 per loop).
-  **1** Ethernet connection.
-  **1** Class A USB 1 ports for configuration with a pen drive and 1 Class B for configuration from SC250 software.
-  **64** network nodes.
-  **1 GHZ PROCESSOR**, high-speed microprocessor core.
-  **512 MB RAM**. It allows all information to be processed quickly.
-  **8 GB FLASH** of internal static memory stores the software, image databases, etc.
- 1.000.000** events in the history log.

## 1.9. ARCHITECTURE

The modular design of the CAD-250 control panel allows up to 3 modular components to be combined in a single structure of up to 4 sections or cabinets.

This feature provides CAD-250 control panels with extraordinary versatility and power. As such, nodes or single control panels can be generated with a capacity of:

- 32** loops
- 8000** devices
- 2000** programmable zones
- 250** areas
- 1000** groups
- 250** virtual controls or relays
- 2500** special modes

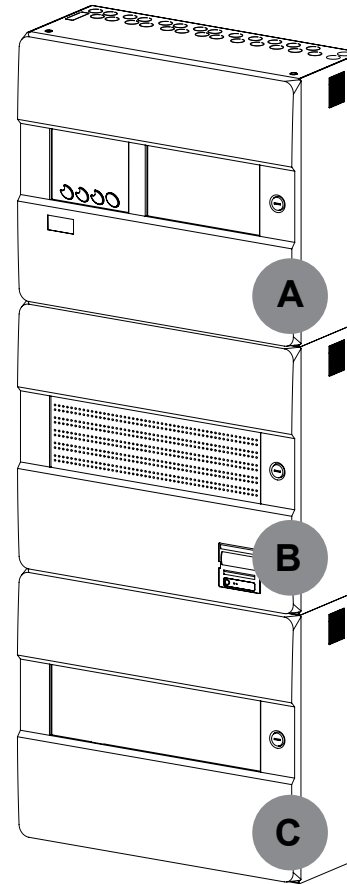

Item	Ref.	Description
A	CAD-250	Main cabinet with interface Expands up to + 8 loops The ref. does not include the loops
B	CAD-250-BLED	Cabinet with 250 dual LEDs for zones Expands up to + 8 loops The ref. does not include the loops
C	CAD-250B	Blind cabinet to expand up to + 8 loops The ref. does not include the loops

## System composition

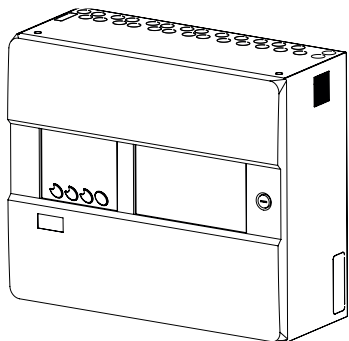

1 x CAD-250

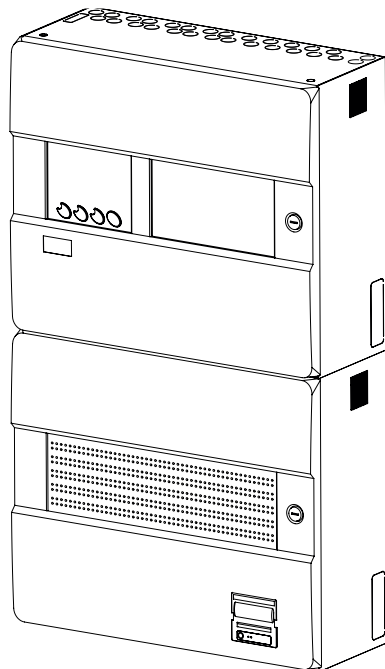

1 x CAD-250 +  
1 x CAD-250LBLED

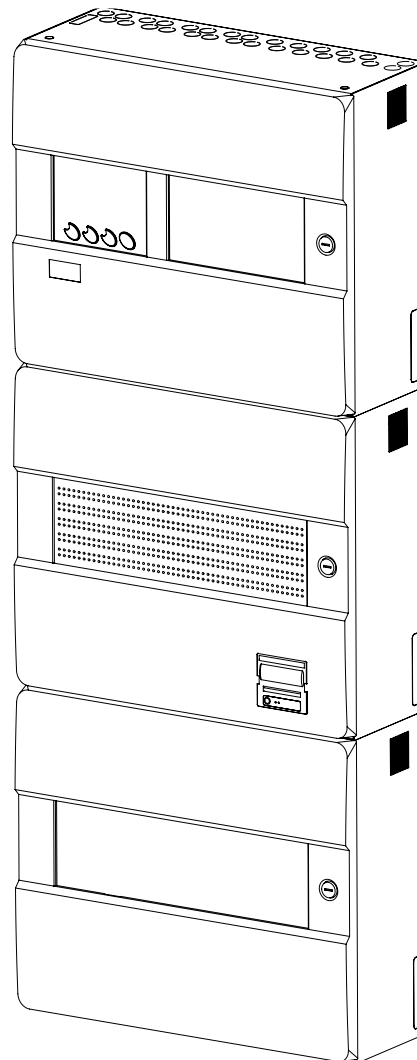

1 x CAD-250 +  
1 x CAD-250LBLED +  
1 x CAD-250 B

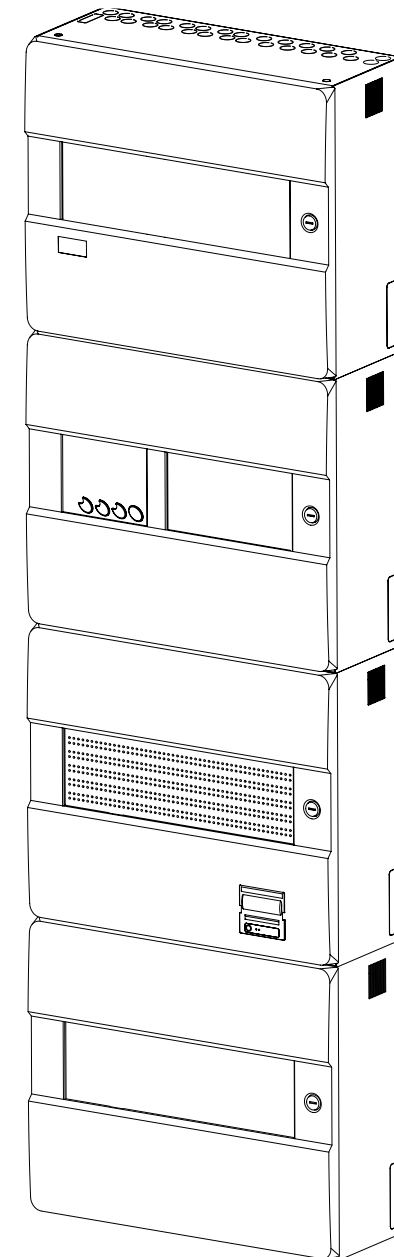

1 x CAD-250 +  
1 x CAD-250LBLED +  
2 x CAD-250 B

Each option of the main control panel or expansion control panels includes:

Main board, which provides the following options:

- 2 monitored sounder outputs
- 2 voltage-free relay outputs on the board
- 1 auxiliary output of 24 V 500 mA
- Capacity for the installation of 4 cards of 2 loops ref. TBUD-250
- 1 power supply
- Space for BTB-1224 batteries

### OPTIONS

- 1 network card, ref. TMB-250, per network node (control panel set) or
- 1 fibre optic network card, TMBFI-250, per network node (control panel set)



## Network system composition

Architecture with TMB-250 network card. RS485 standard communication.

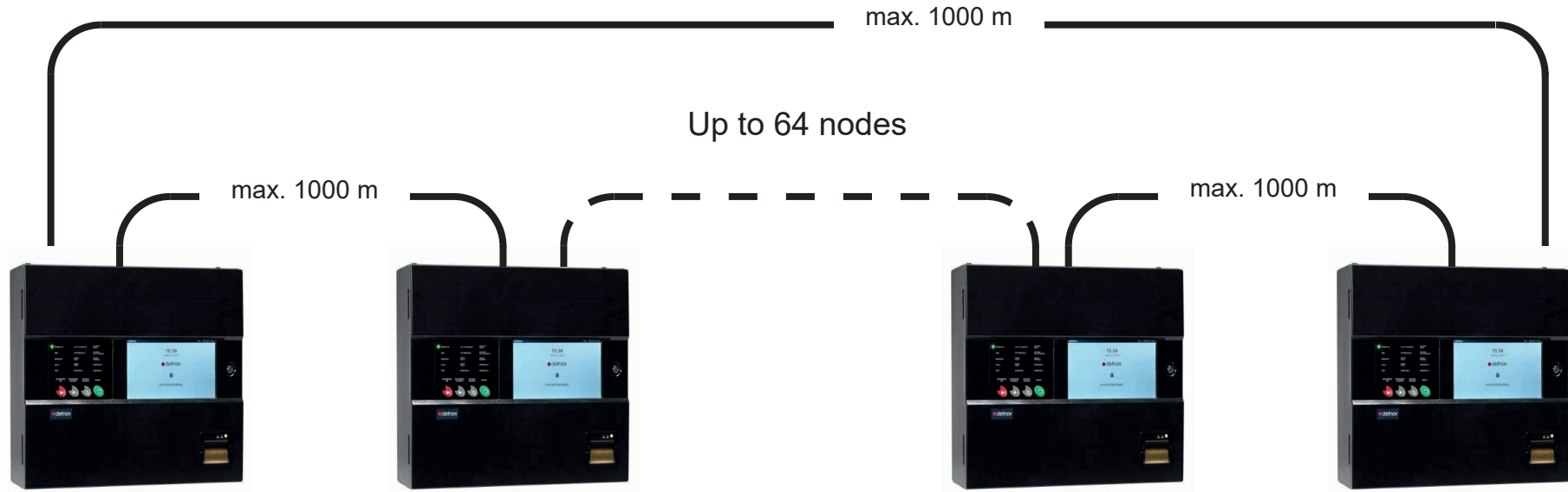



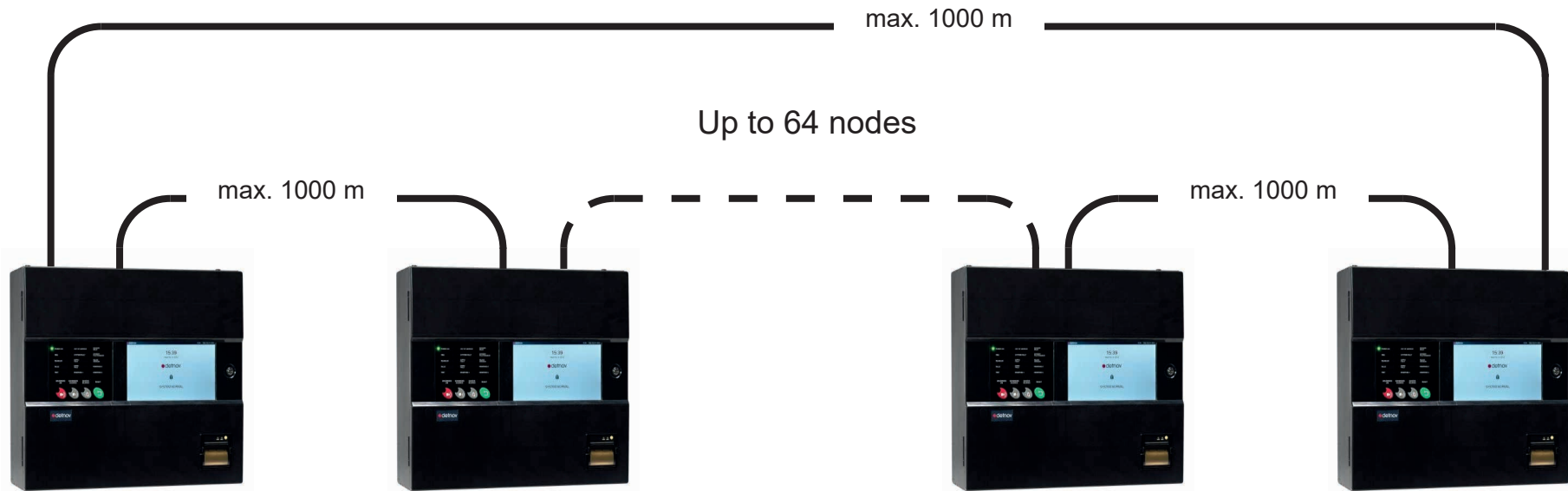





Architecture with TMB-250FI-250 network card. Communication via single-mode fibre cable.

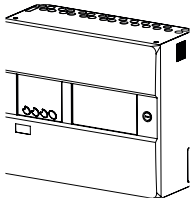

It is possible to create hybrid cable/fibre architectures. Depending on the information requirements of the system, it may be advisable to structure the network from the Ethernet port.

## 1.10. INSPECTION

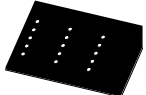
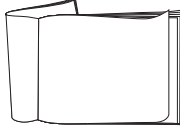
Before unpacking the equipment, check that the packaging is not dented or damaged in any way. After unpacking the control panel, before proceeding to install it, check that it is not damaged in any way. Check that the equipment contains the following:

Ref.	Units	Description	Contents
CAD-250	1	Addressable control panel	
	1	Accessories bag	
	2	Keys	
11234720	2	End-of-line sounder monitoring element. 4K7 1/4w 5%	
24001501	1	20 x 5 500 mA fuse	
	1	20 x 5 500 mA fuse	
24001001	1	20 x 5 10 A fuse	 Main power supply
39310018	1	Battery cable	
55325001	1	Insertable language kit	
55325000	1	Quick guide manual	
39310020	1	Battery jumper cable	

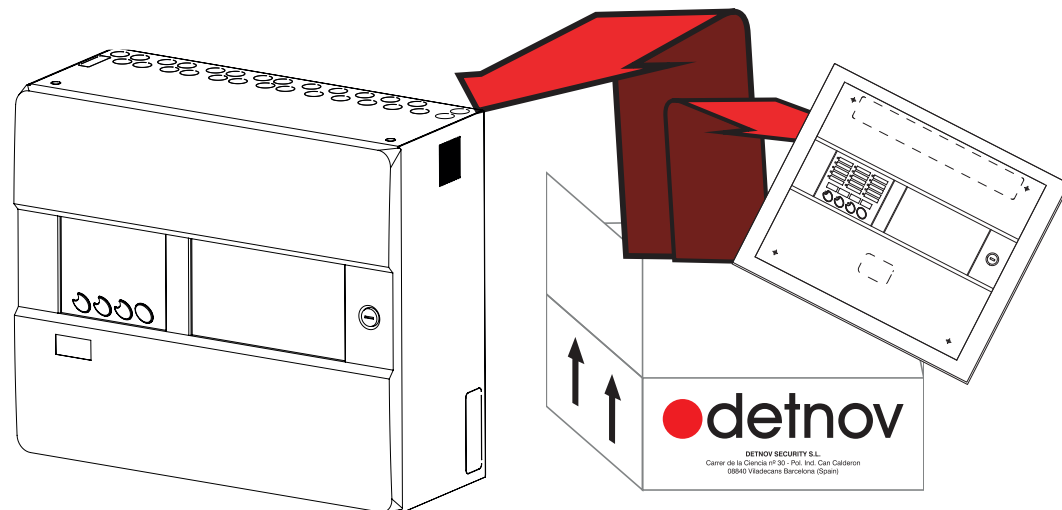

If the control panel is damaged or any of these elements are missing, do not continue with the installation and contact your distributor.

### 1.10.1. Damage to the unit

If the unit is damaged, any accessory is missing or you have queries regarding the explanations in this manual:

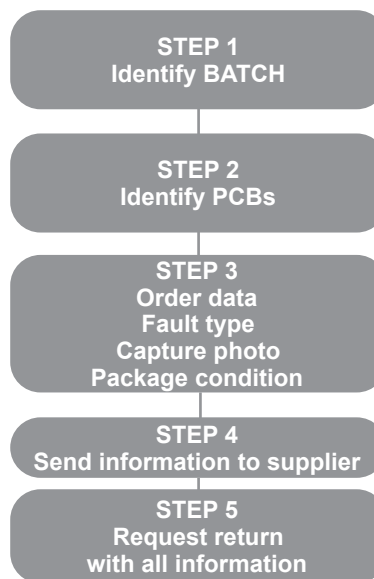

1. Note down the production batch reference number that you can find on the package or inside the box.

2. If the fault comes from the internal circuits, note down the reference numbers that you will find on one of the boards.

3. Note down all relevant details and attach images to your complaint: date of reception of the product, photos of the damage or fault, conditions of the package, etc.

4. Send the data to your supplier.

5. If necessary, send the product to your supplier using the original packaging.

## 1.11. REQUIREMENTS

### 1.11.1. Assembly notes

**KNOWLEDGE:** Make sure you have the necessary mechanical and electrical knowledge to assemble this panel on the wall and implement the necessary connections to your mains network.

**TOOLS:** To assemble the control panel, you will need:

- An electric drill.
- A Phillips or Pozidrive screwdriver.
- A small flat screwdriver for the terminals.
- Insulating tape.
- Measuring tape.
- Cutter.
- 4 lag screws 5.5-6 mm in diameter and 40 mm in length.
- 4 DNP8 wall plugs (8 mm in diameter).

### 1.11.2. Installation notes

Once the control panel is assembled and connected to the mains network, you can carry out an initial start-up and configuration. The detection control panel must only be installed in a dry, clean and well-lit area with restricted access.

Prevent electrical/electromagnetic and mechanical interferences, such as installing the panel close to fluorescent lights, electrical power lines, surfaces that vibrate or are unstable and thin partition walls

### 1.11.3. Detection loop wiring

The wiring must be checked by a certified installer to make sure that all connections work properly and there are no earth faults.

**EN  
UNE  
ISO** All wiring must comply with applicable local standards. Observe the requirements of the **UNE 23007-14** standard for wiring and interconnection of a fire alarm system.



If the zone to be protected is a classified area affected by directive 94/9/EC, ATEX, be sure to design the installation and use equipment that meets the classification requirements.



Danger of electric shock. Disconnect all power from the panel before carrying out any work

A loop cable transmits data, so choosing the right cable is important. Observe the following:

- The loop cable must not exceed 2 km, including possible branches (not recommended).
- Only twisted pair and shielded cables must be used. The cables must circulate through ducts that are separated from other circuits to prevent problems of interference.
- The screen must always be earthed at a single point. Use the connection points described for the mesh.
- The mesh must have continuity throughout the loop ring path.
- Although for a standard facility the cross section of the loop cable is usually 1.5 mm<sup>2</sup>. Calculate the exact cross section required for your facility.
- The sheath for the cable intended for fire detection applications is normally red.
- The cables specified for the loop circuits are also suitable for alarm, auxiliary alarm and input/output transmission lines.
- All cable sections must be circular so that the cable is secured effectively, using cable glands.

## 2. ASSEMBLY GUIDE

This section will explain how to attach the control panel securely in its final location. Before fixing the control panel to the wall, read this section carefully and plan how you will install it in order to prevent future faults or unnecessary actions.

### 2.1. CABLE ENTRIES

The CAD-250 has various cable entries. The entry covers can be removed easily using pliers.



Do not remove more covers than those you will use to prevent any openings on the box. Close them before connecting the power supply to the control panel. Otherwise, you will leave zones exposed that have voltage risks.

To remove a cover, bend it with pliers several times until it comes off.

#### 1 ENTRIES FOR CABLE GLANDS

The upper part of the box has 28 pre-cut entries with a diameter of 24 mm in order to use cable glands. These holes are useful when the cables come through tubes or in a hose.

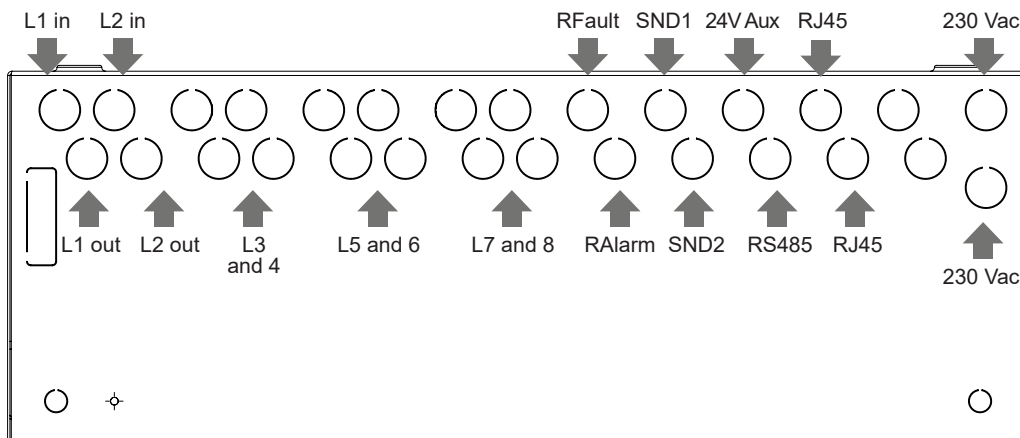

### 2 REAR CABLE ENTRY

The back of the box has a large rectangular shape in the upper area. Use this entry when the cables to enter come directly out of the wall on which you are going to install the control panel.

### 3 SIDE CABLE ENTRY

The control panel has two rectangular cuts in the lower area on the right and left sides. These entries are practical if you are using a conduit to guide the cables.

### 4 CABLE ENTRY FOR ASSEMBLING VARIOUS SECTIONS

The upper and lower faces have two small rectangular cuts on the left side that allow the passage of the expansion cables in case of a tower-type device (up to a **maximum of 4 cabinets** can be installed, see section 1.9.).

### 5 ADDITIONAL REAR INPUT

The back has a rectangular shape in the lower area, which may be useful, for example, if you install the control panel in a cabinet.

### 6 LOWER INPUT

The lower face has a rectangular shape, which is useful, for example, for connecting an external power supply with the UNE EN54-4 certification.

### 7 CABLE ENTRY FOR THE MAIN POWER SUPPLY

Do not cross the main power supply cable over the control card. To do this, use the cable entry on the right to insert the cable to connect to the mains network, as it is closest to the control panel's AC connector.

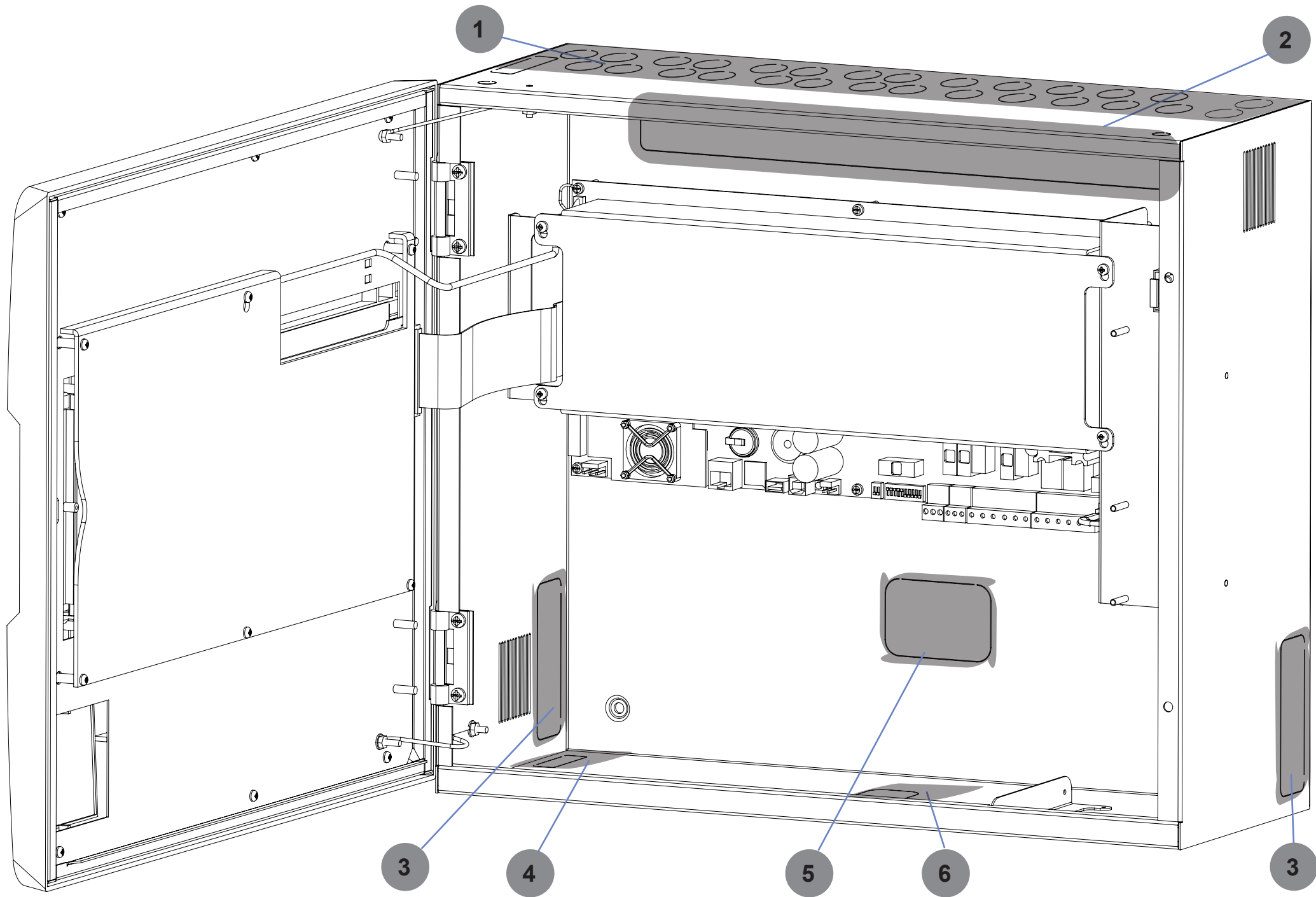

## 2.2. ATTACHMENT

STEP 1  
Remove template

STEP 2  
Place template,  
check level

STEP 3  
Drill holes in the wall

STEP 4  
Fit the wall plugs

STEP 5  
Attach the control  
panel

The CAD250 control panel's cardboard packaging contains a printed template that allows the fixing holes to be made in the wall and the positioning of the control panel to be checked easily. It will also prevent you from having to hold the control panel to carry out this task.

1. Take the template out of the cardboard box.
2. Place the template on the wall using a level for correct orientation with regards to the floor. Fix the template to the wall using insulating tape so that your hands are free.

 The fixing template shows the main screen of the unit. Place the template so that the upper part of the screen is at an approximate height of 1.5 metres from the floor.

3. Using the appropriate drill bit (for holes of 6 mm, use drill bit no. 12), drill the 4 holes.
4. Put the wall plugs in the holes, making sure they are secure.

 Use the recommended wall plugs and screws, as the control panel can weigh up to 40 kg (depending on the batteries installed). Take into account any cable or installation that can pass over, under or behind the unit.

5. Fix the rear box to the wall using all of the holes and screws. The box permits 6 mm screws (no. 12) (do **NOT** use countersunk screws).

 Tighten the screws until they are fully inserted into the hole. Prevent the control panel from moving due to the weight of the batteries and, therefore, the screws or wall plugs from becoming loose.

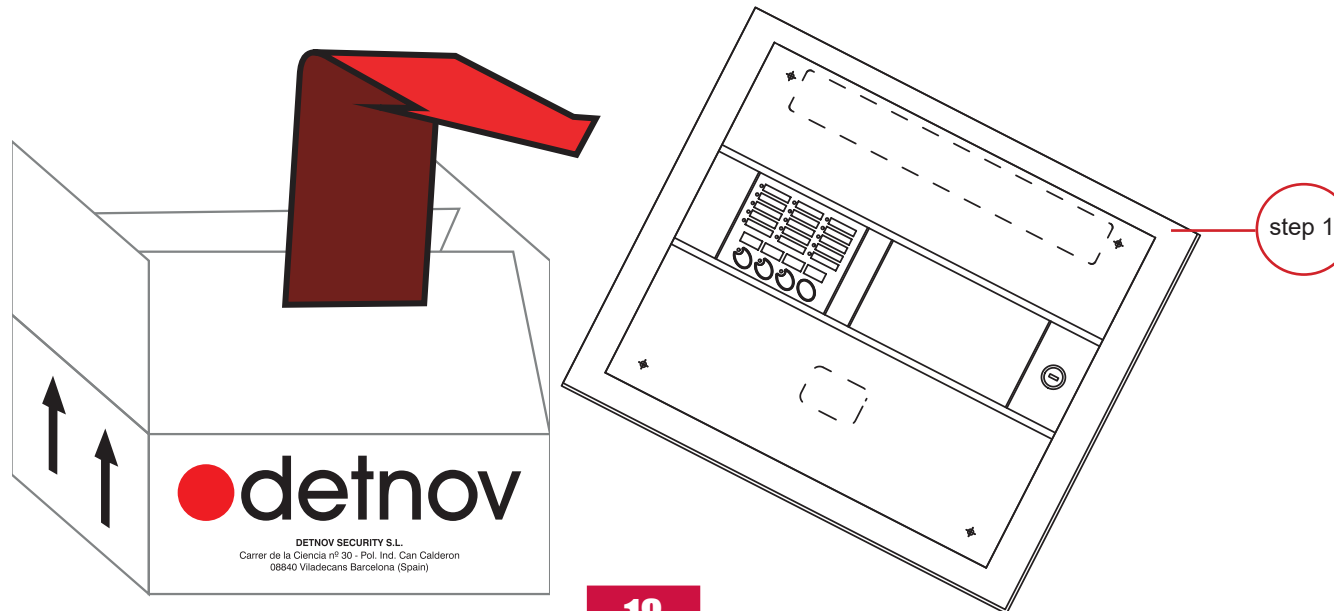

4x WALL  
PLUGS  
DNP8 (8 mm)

4x LAG SCREWS, 5.5 mm x 40 mm  
PHILLIPS/POZIDRIVE ROUND HEAD



step 4

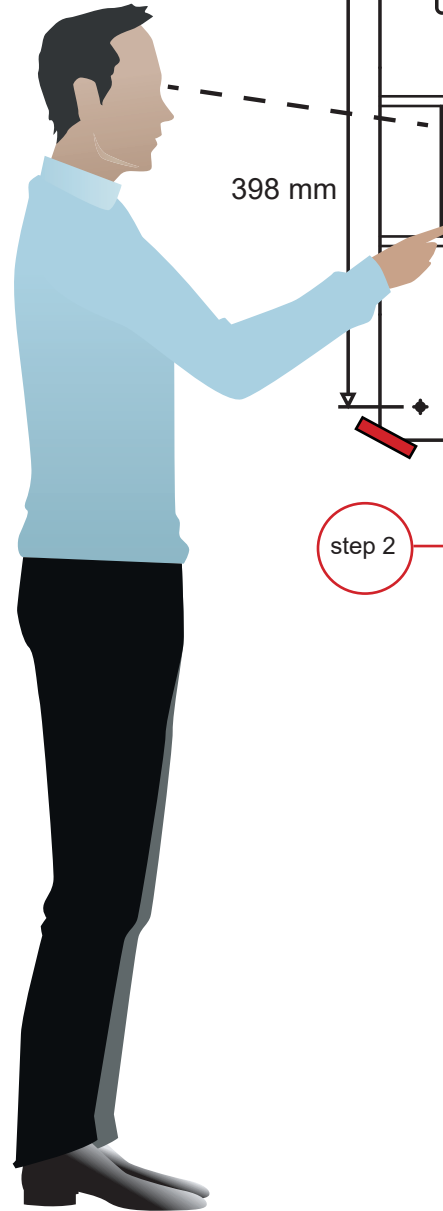

398 mm

step 2

1.5 metres

452 mm

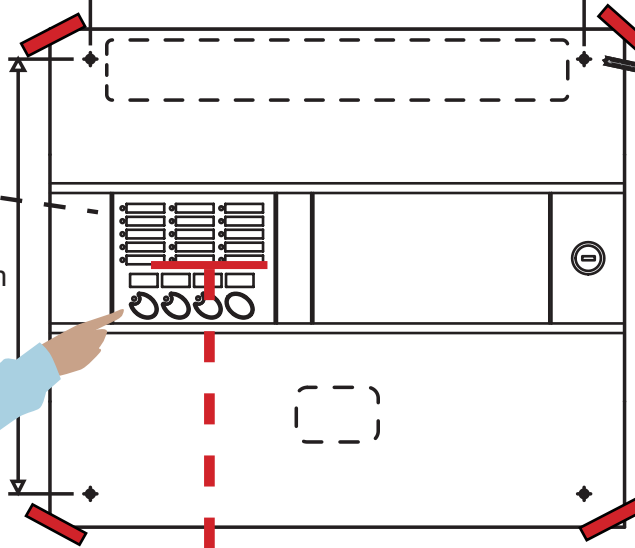

step 3

## 3. CONNECTION GUIDE

### 3.1. INTERNAL PARTS

Before making any type of connection, identify the internal parts of the control panel and familiarise yourself with their location.

To open the door, you will need to unlock its lock. Use the keys supplied with the CAD-250 control panel (see page 10).

 The person responsible for the facility must know where these keys are in order to access the interior of the control panel.

#### 1 AC AND FUSE MAIN CONNECTOR

This is the main current input to the control panel. The main input cable for the 230 Vac power supply must be connected to this power supply terminal block (power supply fuse) located on the upper right part of the box.

#### 2 MAIN BOARD PROTECTION

Protect the MAIN BOARD from contact with metal elements or from damage. To proceed with the placement of the loop cards, it is necessary to remove it and replace it once you have finished the installation.

#### 3 POWER SUPPLY

Convert the mains power (230 VAC) into direct current (24 V) and stabilise it. The control panel power supply is cooled passively, so it is important that its air circulation is not impeded. Do not place the surplus coiled cable on the upper area of the power supply support, instead leave the exact cable plus 10 cm.

#### 4 ADDITIONAL CARD SUPPORT

This board protects the power supply and serves as a support for the AC connector, as well as being the fixing point for ADDITIONAL CARDS. Additional cards are supplied with the necessary elements to fix and connect them.

#### 5 MAIN BOARD

The MAIN BOARD contains the main processor, CPU, fuses, electronics, expansion connectors and stores the loop cards.



Avoid any metal contact with any part of this card when it is powered or it could cause irreversible damage to the unit.

#### 6 BATTERY CONNECTOR

When you connect the battery cable terminal, make sure this connector has a specific connection position; do not force it as you could damage the main board.

#### 7 POCKET FOR THE INSERTABLE LANGUAGE CARD

This is where the language card is fitted. From the front, you will see, once you have inserted the card, the legends that accompany the LEDs and control keys and primary LEDs (see sections 3.2 and 4.2).

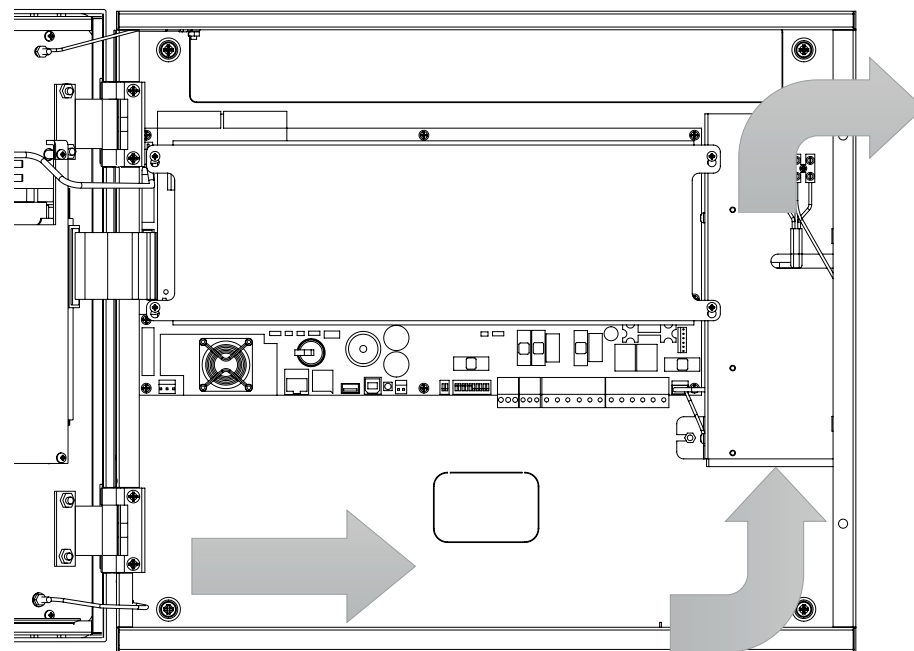

Ventilation airflow of the CAD250 cabinet



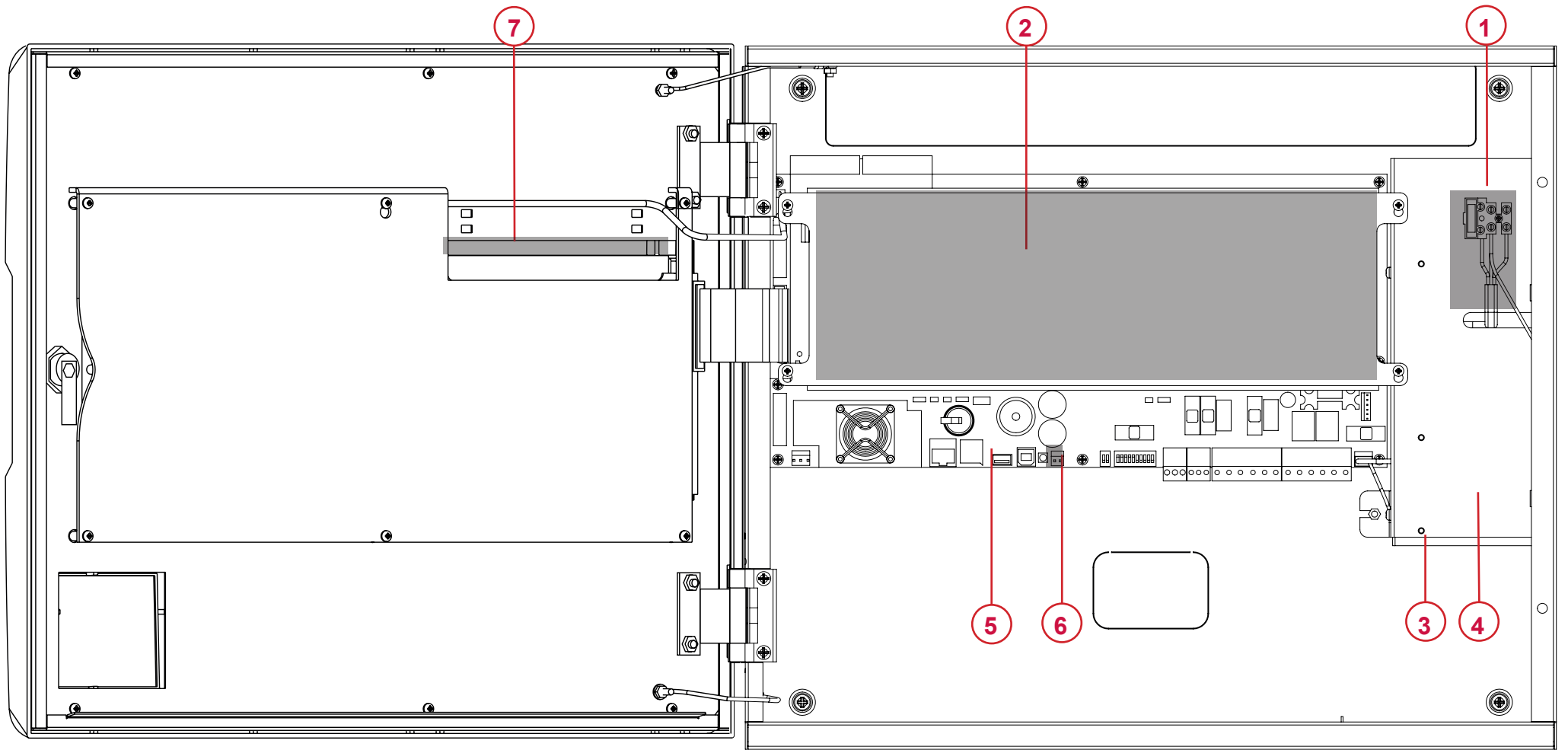

### 3.2. INSERTABLE LANGUAGE CARD

The CAD-250 control panel is prepared to operate in different languages, regardless of the internal language configuration of the control panel software, with a language card package supplied with the control panel.

Using these language cards, you can customise the language of the LEDs and PRIMARY CONTROLS (see sections 3 and 4.2), which, once installed, show the text associated with each LED and each CONTROL through transparent windows.

To place the language card into the CAD-250, follow the steps below:

1. Locate the pocket for the insertable language card on the inside of the door (see section 3).
2. Insert the card into the pocket from top to bottom.

 Exercise caution when inserting the language card, try not to strain or force the control cable of the panel interface, which is above the insertion mouth of the language card. Once you have inserted the language card, check that it is aligned by looking at the control panel from the front.

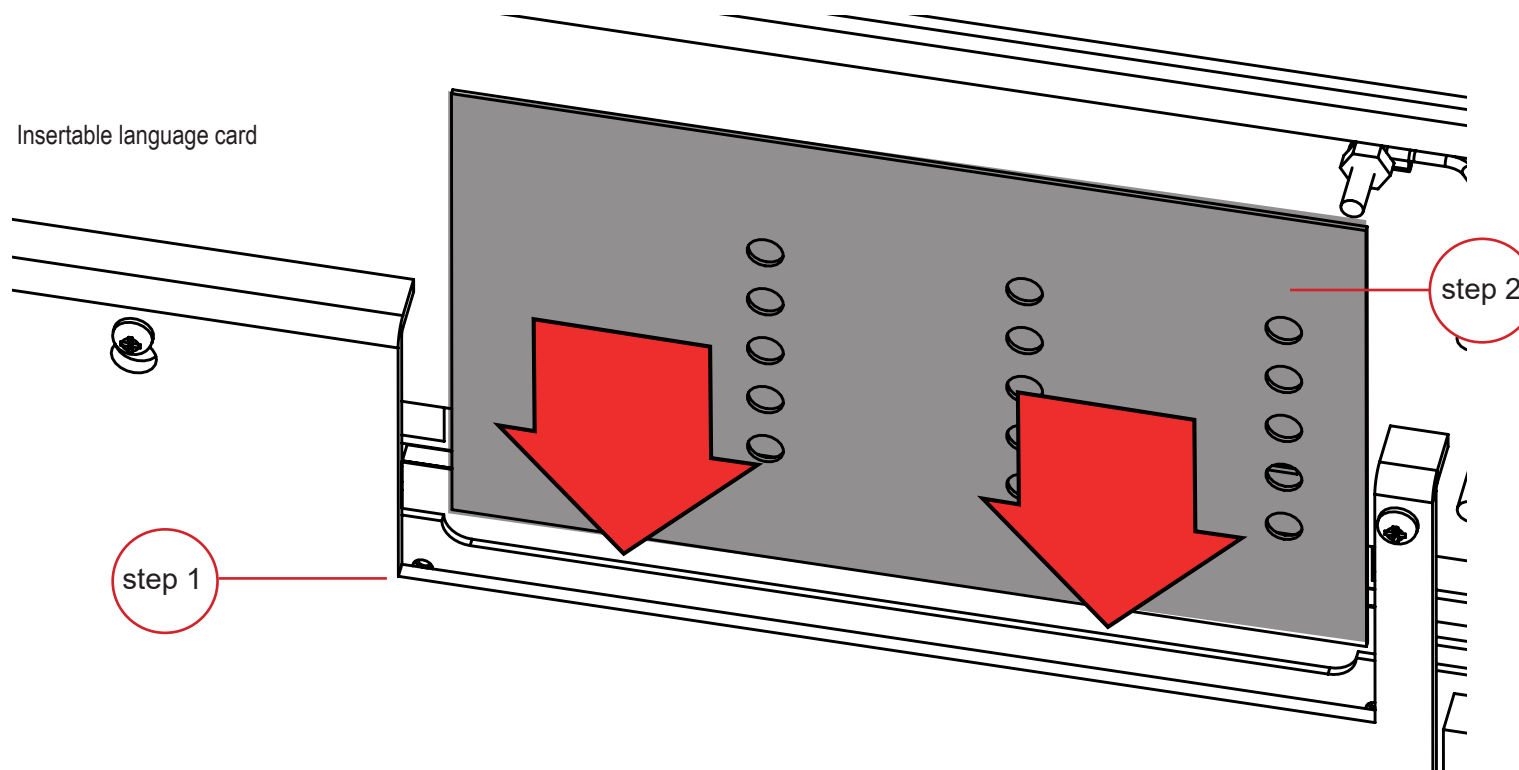

### 3.3. MAIN BOARD PROTECTION

To remove the MAIN BOARD protection, follow the steps below:

1. Locate the MAIN BOARD protection (see previous page).
2. Loosen the 4 screws that retain the protection using a Phillips screwdriver.
3. Move the protection UP slightly and PULL to remove it.





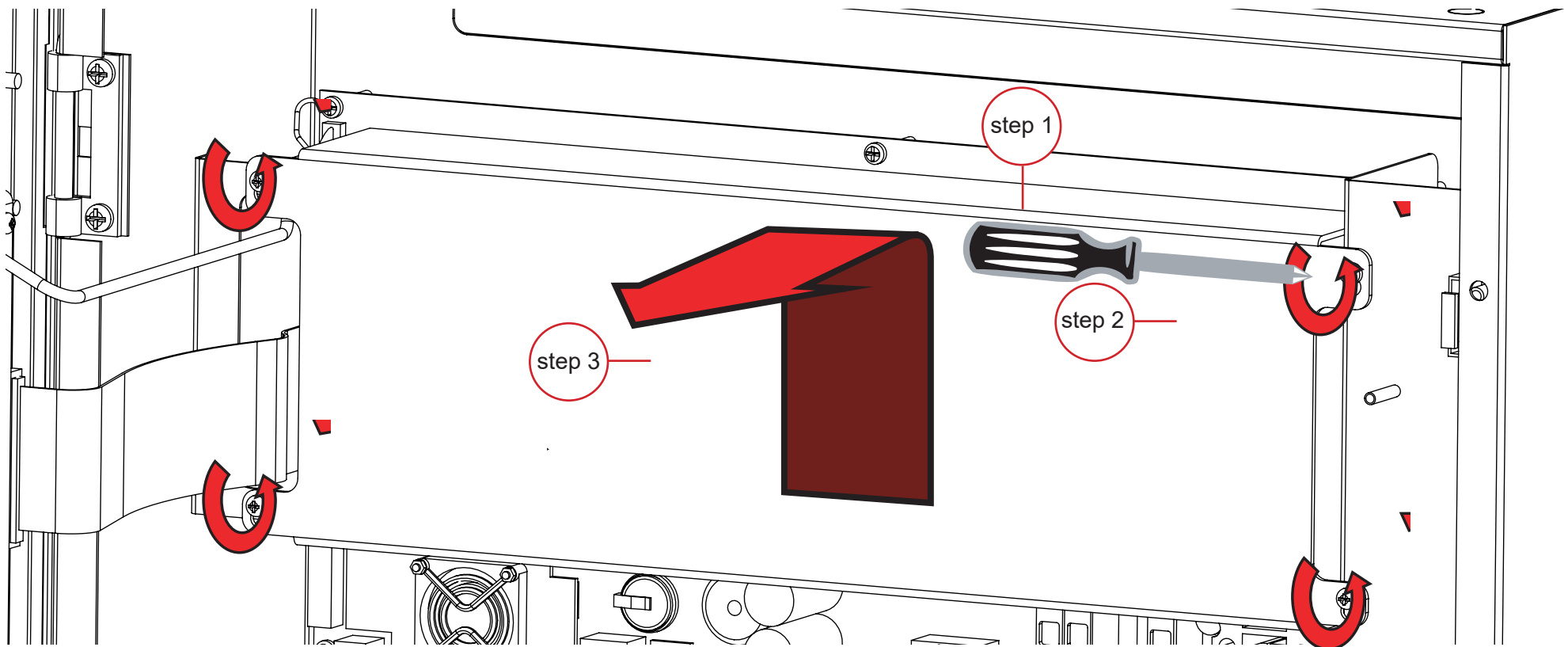

 It is not necessary to remove the screws that secure the MAIN BOARD protection. When reassembling the protection board, try not to press the retaining screws excessively, as this could damage their threads or impair the protection.







 Make sure you are not wearing any metal accessories (rings, bracelets, etc.) that could short circuit the electronics.

Removal of the main board protection



### 3.4. MAIN BOARD

Item	Ref.	Description	Comment
1		LOOP CARD	 Loop input, output and mesh connection. They are assembled from left to right. Up to 4 cards
2		MAIN PROCESSOR	
3		ETHERNET	 It connects the control panel to the network and allows: Automatic clock update, Connection to other control panels, Upload/download of databases and configurations Firmware update
4		SD READER	Card reader for factory use only
5		BATTERY	CR2031-type button cell for the internal clock.
6		USB TYPE A	 Allows databases, configurations or software updates to be uploaded/downloaded using a PEN DRIVE.
7		BUZZER	It sounds if there is an alarm, fault or event set as an alarm.
8		USB TYPE B	 Port for uploading/downloading databases and configurations of the control panel, updating the firmware from a PC that has the configuration software installed.
9		BATTERY STARTER SWITCH	It allows the control panel to be started without mains power if the battery has enough charge.
10		BAT	Power supply input connector of the control panel via the auxiliary battery. Only use the recommended batteries (see section 3.11).
11		SW2	 Establish the identification of the cabinet in the combined tower control panel.
12		BAT FUSE	10 A battery fuse
13		SW3	

Item	Ref.	Description	Comment
14		J32	Jumper for Buzzer off. Disconnects the internal buzzer ONLY in case of a SYSTEM FAULT.
15		J7	 Jumper for Earth Leakage Detection. Disconnects the fault generated by an earth leakage.
16		RS485	 External channel input reserved for future applications
17		RS485	 External channel output reserved for future applications
18		AUX FUSE	Auxiliary output protection fuse.
19		SND1 FUSE	Sounders output 1 protection fuse. 500 mA
20		24 VDC AUX.	24 V 500 mA auxiliary output connector
21		SND1	Monitored output 1 connector for sounders
22		SND2 FUSE	Sounders output 2 protection fuse. 500 mA
23		SND2	Monitored output 2 connector for sounders
24		R.ALARM	 Output contacts for alarm relay type C-NO-NC, voltage-free.
25		R.FAULT	 Output contacts for fault relay type C-NO-NC, voltage-free.
26		VIN	24 Vdc power supply input for the main base card.
27		GENERAL FUSE	General protection fuse for the base control card
28		EXPANSION	Connector for additional expansion card
29		EXPANSION INPUT CONNECTOR	Input connector for the configuration of various control panel sections
30		EXPANSION OUTPUT CONNECTOR	Output connector for the configuration of various control panel sections

3.4 Main board

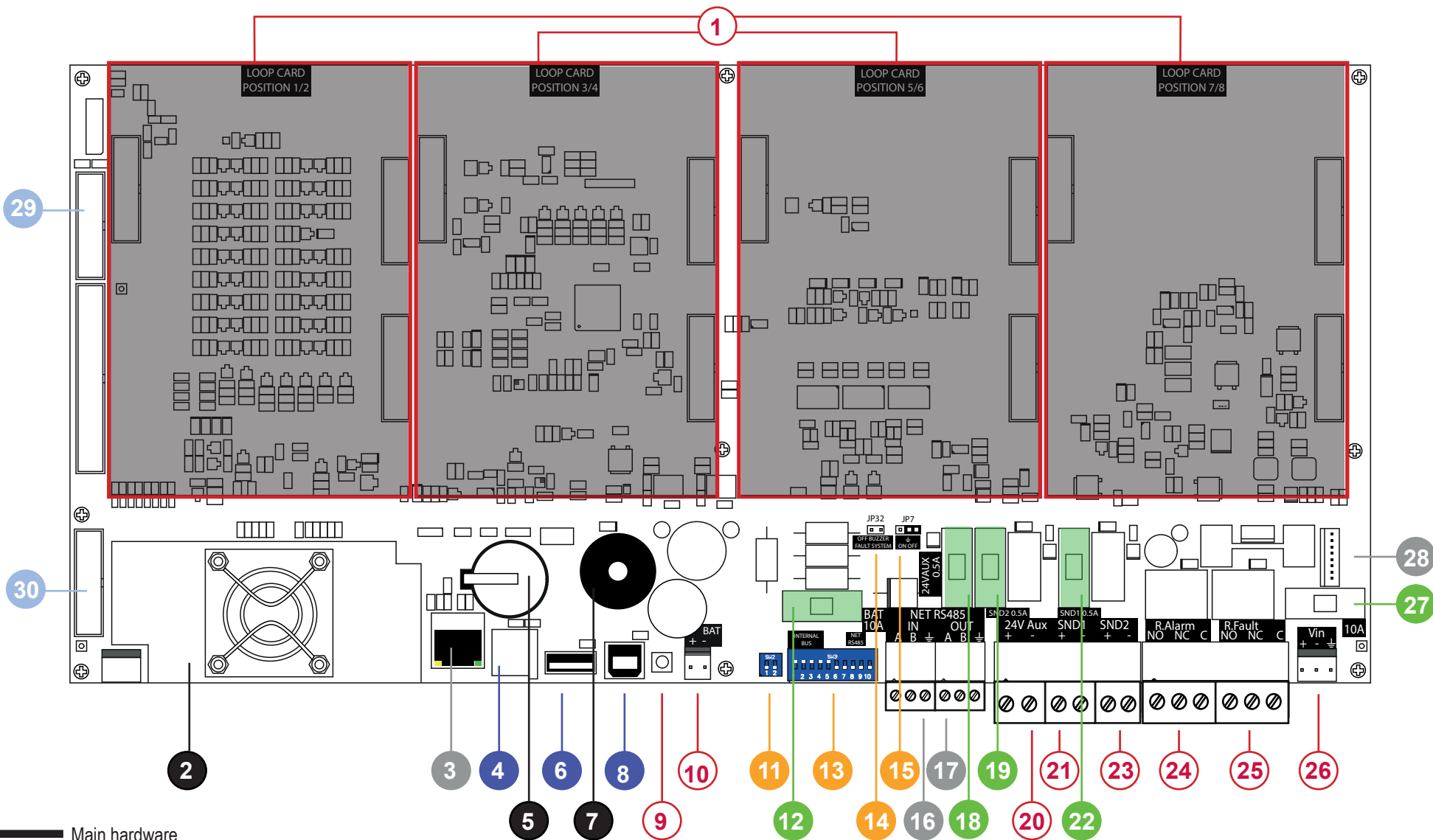

- Main hardware
- Main connectors
- Communication ports
- Update ports
- Configuration jumpers
- Fuses
- Expansion connectors

**IN THE CAD-250B AND CAD-250BLED CABINETS, THE SOUNDER AND RELAY OUTPUTS ARE NOT FUNCTIONAL.**  
**ONLY USE THE MASTER CABINET OUTPUTS ON CAB-250**

### 3.5. CONNECTION TO THE MAINS

**⚠ WARNING!:** Make sure the differential lever is in the open or disconnected position.

ENG

Although the consumption of the CAD-250 control panel is not too high, it is important to install a double pole differential to prevent short circuits.

To connect the CAD-250 to the MAINS, carry out the following steps:

1. Remove the fuse holder.
2. Pass the power cable through the most appropriate box input.
3. Connect the EARTH, N and L cables to the corresponding terminals on the CAD-250 strip connector.
4. Connect the N and L cables to the corresponding terminals on the DOUBLE POLE DIFFERENTIAL and the EARTH cable to the appropriate terminal.
5. Fit the fuse holder.

**⚠** Do not use the fuse holder as a switch. Only use an external double pole circuit breaker.

6. Check that the power that reaches the safety device is within the functional range of the control and indication unit (230 Vac)  
Raise the differential lever to close the circuit.
7. Using a multimeter, check the voltage supplied by the mains network.

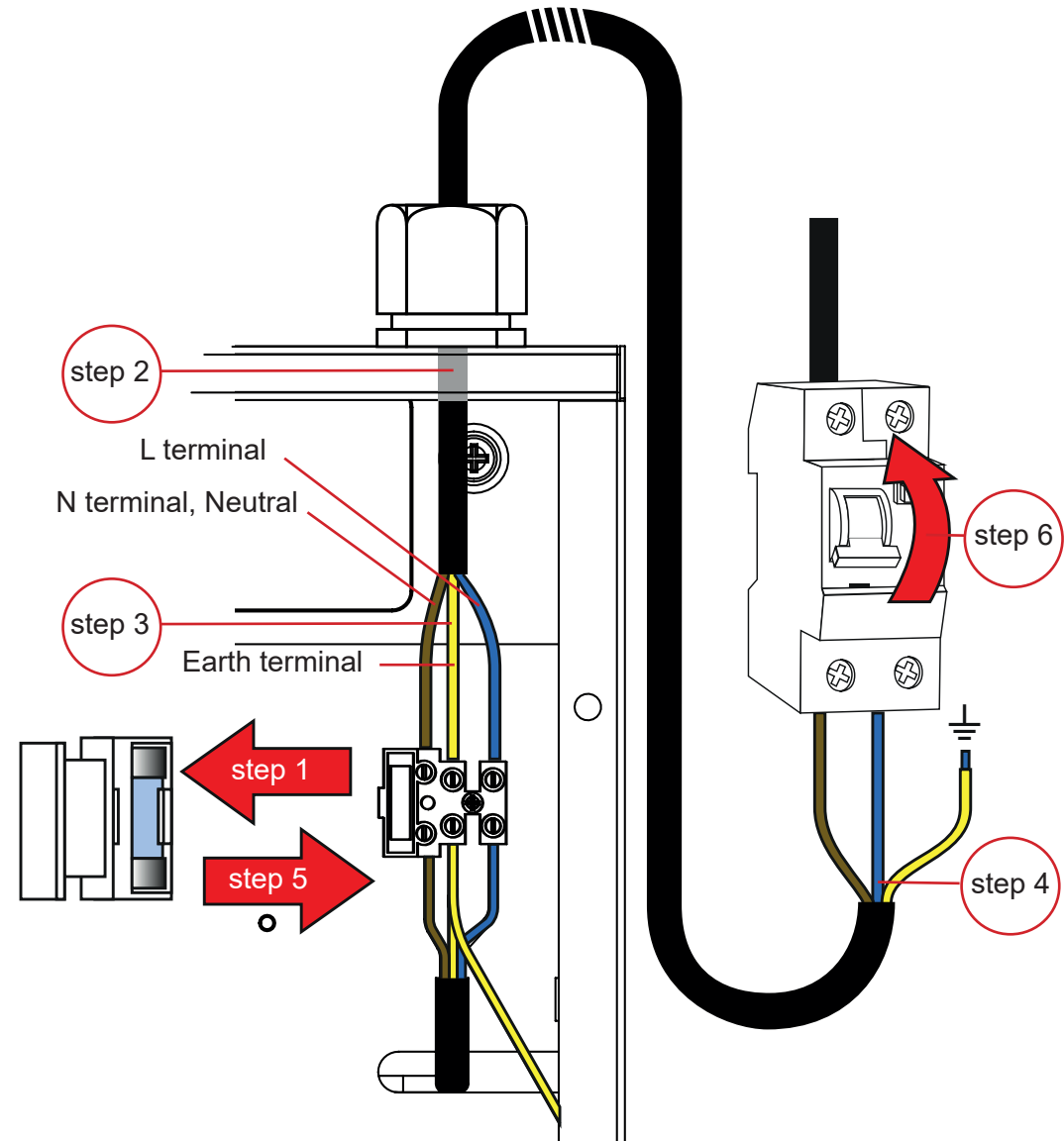

### 3.6. CONNECTING THE BATTERIES

For the CAD-250 control panel to operate correctly, it uses two 12 V lead-acid batteries connected to each other in series, providing a voltage of 24 V. The batteries are not supplied with the control panel.

The control panel box has enough space to house two 24 Ah batteries (the recommended batteries are YUASA NP24-12 or equivalent). The useful life of the batteries depends on the working conditions, especially the ambient temperature. Consult the manufacturer's specifications.

To install the batteries, carry out the following steps:

Only use batteries of the recommended capacity. A lower capacity will provide less autonomy when there is a mains network fault.

1. Put the batteries into the control panel so that the  $\oplus$  terminal of one of the batteries is next to the  $\ominus$  terminal of the other.
2. Locate the BATTERY CONNECTOR (see section 3.4).
3. Install the jumper between the closest  $\oplus$  and  $\ominus$  poles of the two batteries.

According to the model and charge capacity of the battery, the connection terminals on the batteries may differ.

4. Connect the BLACK cable to the  $\ominus$  terminal free of one of the batteries and the RED cable to the  $\oplus$  terminal free of the other battery.
5. Connect the pin in the correct position to the BATTERY CONNECTOR on the MAIN BOARD.



Once the control panel is started (see section) with the batteries connected, the control panel will check the status of the batteries. If the test is not correct, the message 'BATTERY FAULT' will appear on screen. Check the battery connections.

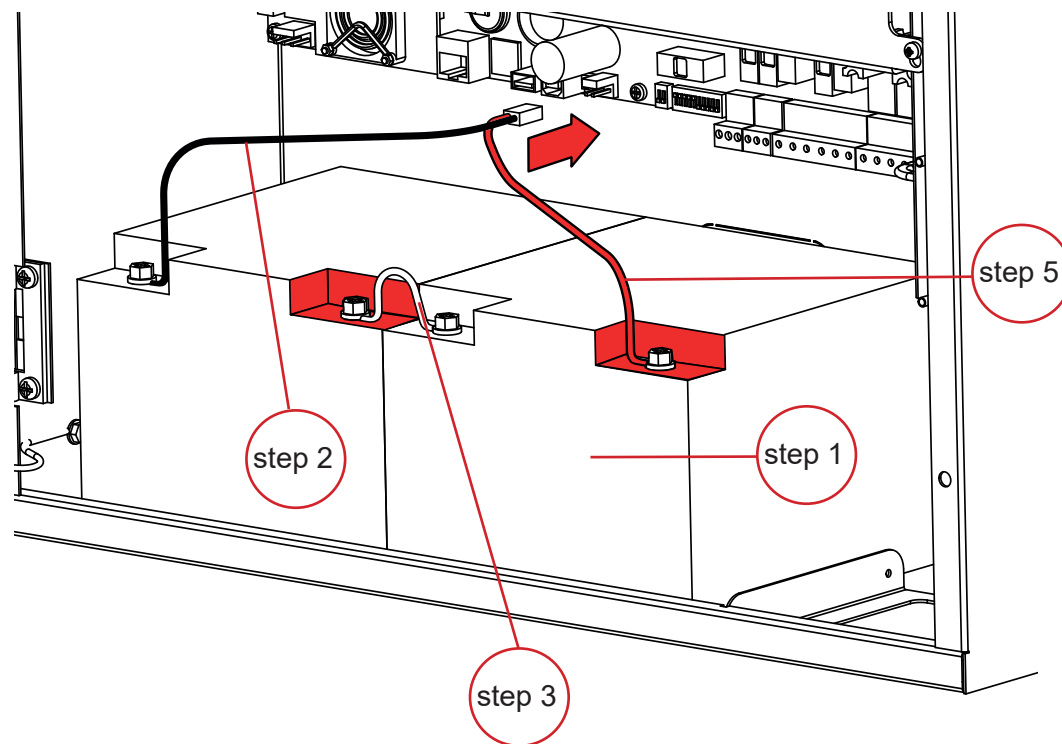
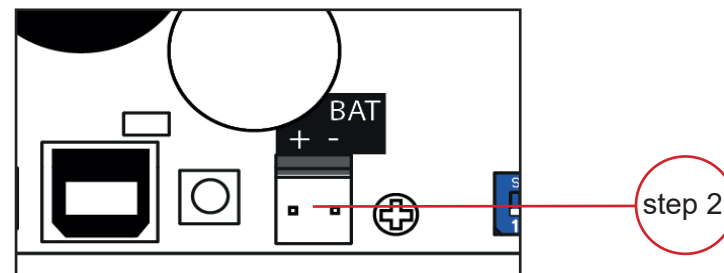

### 3.7. LOOP CARD(S)

Each loop card provides two addressable detection loops. This board is installed on the MAIN BOARD, always starting with the position marked as LOOP CARD POSITION (1/2) and successively occupying the positions to the right of the previous one. The board is fixed using four NYLON screws supplied with the loop card.

To install a loop card on the CAD-250 control panel, carry out the following steps:

**⚠** Make sure you are not wearing any metal accessories (rings, bracelets, etc.) that could short circuit the electronics and take the appropriate antistatic precautions for handling the loop card.

**NEVER** perform the loop assembly and connection operations when the system is powered. Check that the main supply voltage and batteries are disconnected.

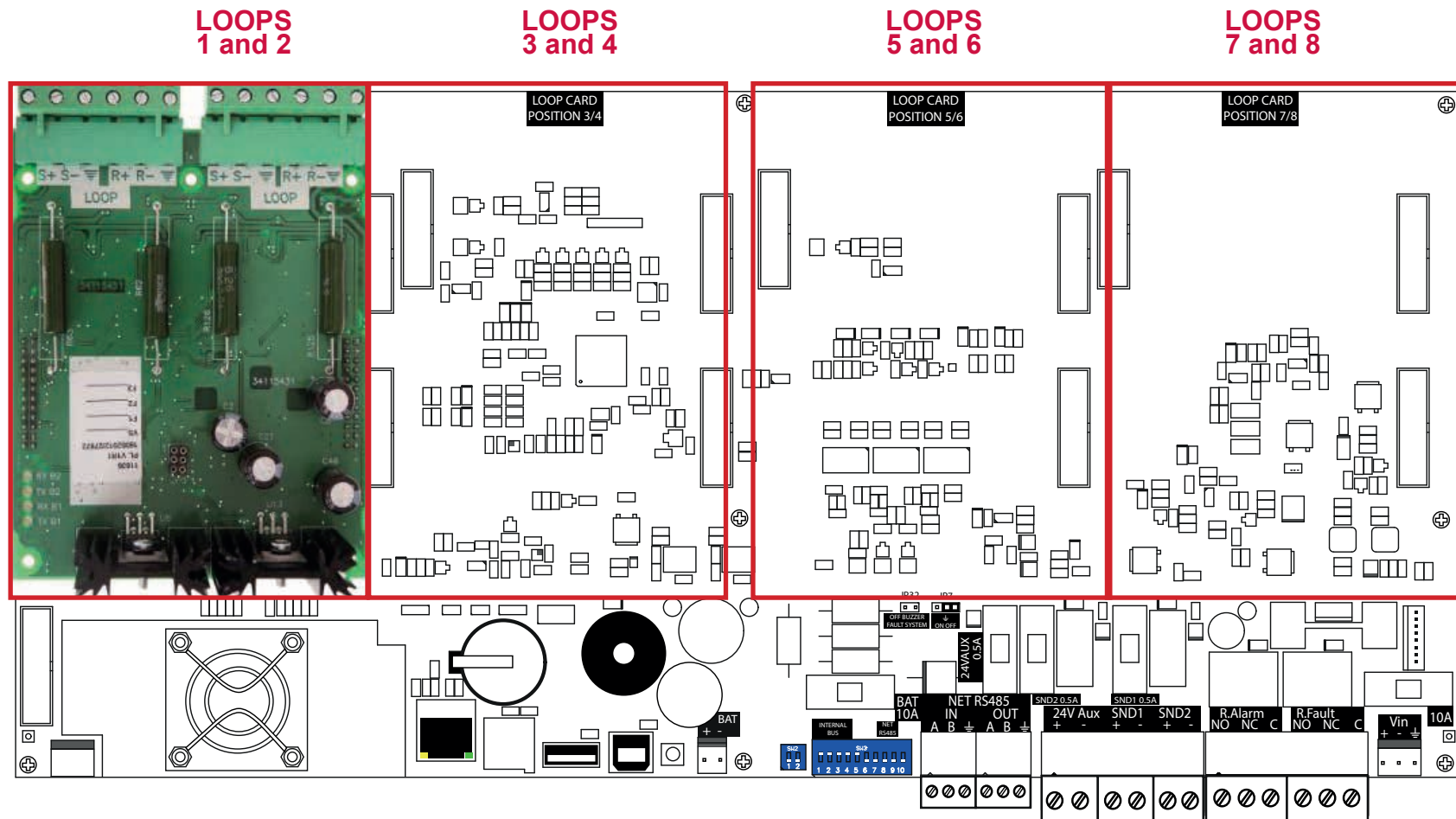



1. Locate the position for the loop card(s).
2. Insert the card into the slots starting with the one marked LOOP CARD POSITION (1/2).
3. Fix the card using the screws included with it.
4. Make the necessary connections (see section 3.7).
5. Remount the MAIN BOARD protection (see section 3.3).

 Check that the card is firmly inserted into the connection slots and use the NYLON SCREWS provided to secure it in place.

 Only use the NYLON SCREWS supplied with the loop card to prevent any damage to the MAIN BOARD, as metal screws can cause short circuits on the main board.

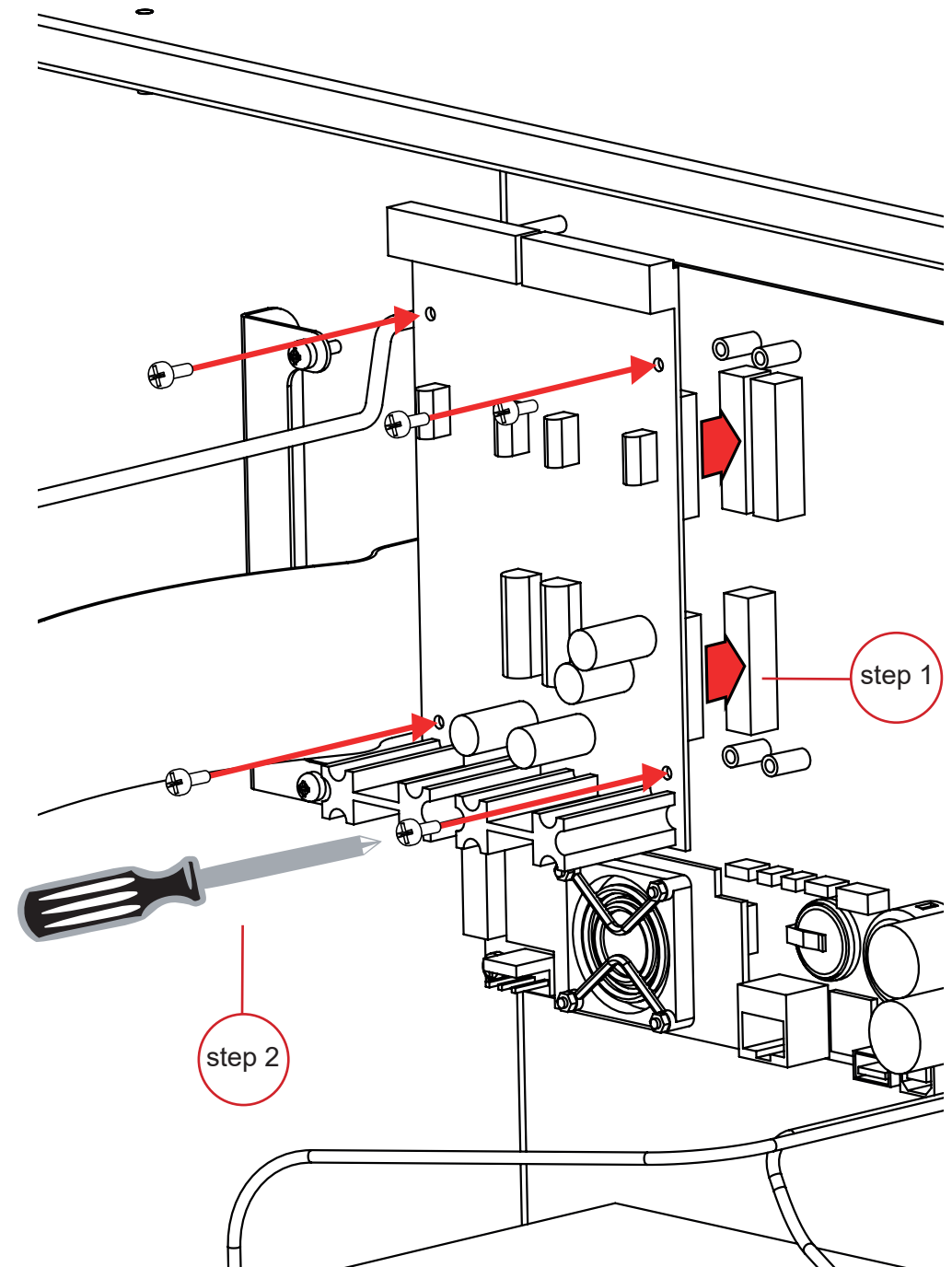

### 3.8. ADDRESSABLE LOOPS

Each loop card can support up to 250 DETNOV addressable devices (sounders, input/output modules, isolators or detectors). In general, all of these devices are powered by the loop itself.

It is possible to subdivide each loop into multiple zones without exceeding the total number of zones of 2000.

EN  
UNE  
ISO

In accordance with the UNE 23007-14 design standard, the maximum number of fire alarm initiation elements per zone is 32. Fire detection systems require the use of a loop topology to prevent a single fault from causing the loss of a significantly large sector



Although branches are tolerated by the system, their use is not advisable and should be restricted.

The cable recommended for the addressable loop is a twisted and shielded cable (between 20 and 40 turns/metre), with a capacity of less than 0.5  $\mu\text{F}$  and a maximum resistance of 44 ohms for the entire loop path. The maximum consumption of the devices connected to the loop must not exceed 400 mA.

The standard cross section is 1.5 mm<sup>2</sup> in diameter for a maximum loop length of 1,500 m, although this may be longer depending on the facility.

The connection terminals on the loop card permit a cross section of up to 2.5 mm<sup>2</sup> in diameter for a maximum distance of 2,000 m of length on the loop.

We recommend that the system wiring is done with two-conductor cables and that each cable is specific to a function.

Use heat-shrinkable terminals and/or sleeves on cable terminations to prevent potential short circuits.

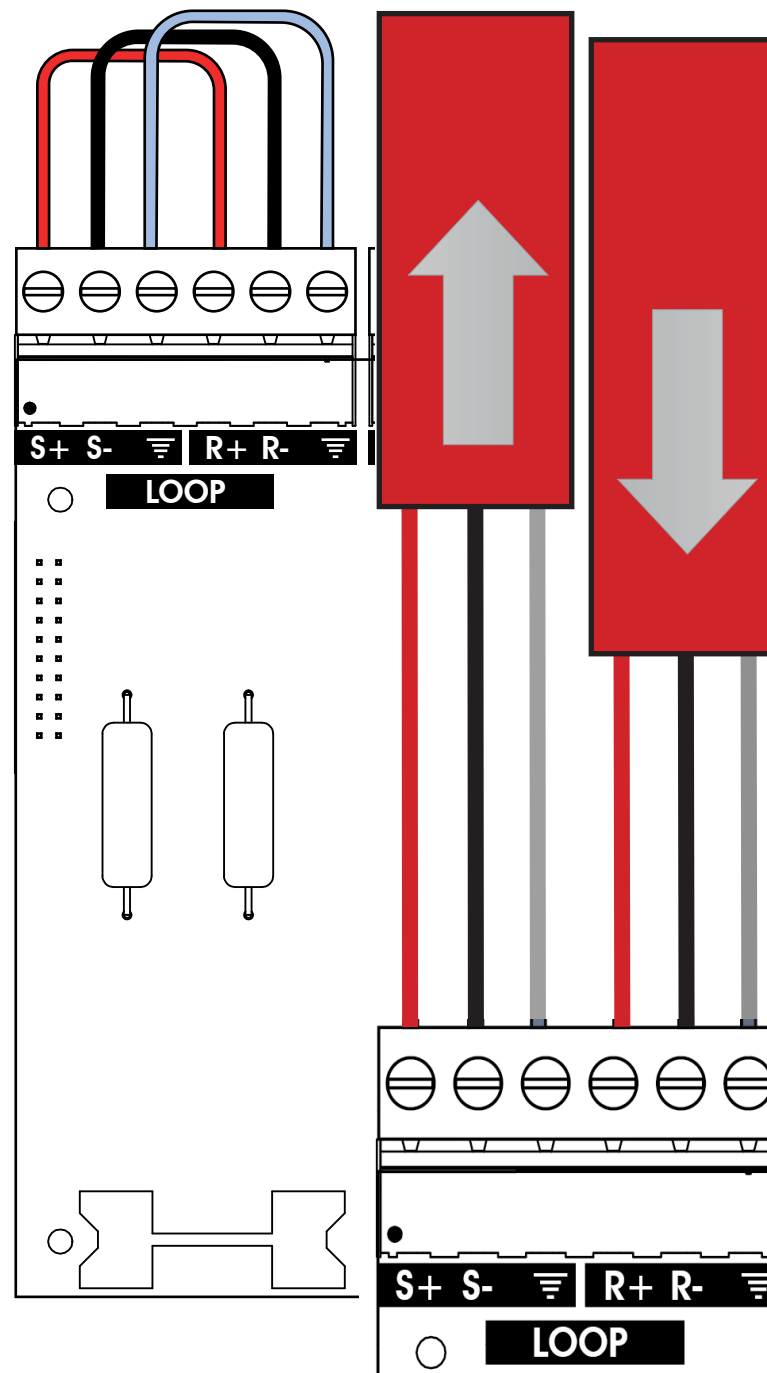

### 3.8.1. Loop continuity

The loop wiring must be implemented as a closed loop, therefore it is essential to ensure the return of the loop line to the control panel.

 Only connect the return of the earth connection to the control panel, never to an external earth connection.

To connect a loop to the loop card, carry out the following steps:

1. Identify the loop output terminals on the card.
2. Connect the positive S+ terminal to the positive loop output cable. Connect the S- terminal to the negative loop output cable.
3. Connect the mesh at the output end of the cable to the outgoing mesh connection terminal ( $\equiv$ )
4. Connect the mesh at the return end of the cable to the return mesh connection terminal ( $\equiv$ )
5. Put the MAIN BOARD protection back (see section 3.3).



### 3.8.2. Connecting devices to the main line

As extracted from section 3.6.1, the continuity of the loop wiring is of vital importance for the proper functioning of the facility and even more so if it is possible to avoid earth faults. In schematic terms, the connection must be similar to the following diagram.

 When opening the loop line to connect it to the + and - terminals of the device, ensure the connection of the two ends of the shield. To do so, wind them up and protect the joint with insulating tape in order to avoid any earth leakage of the mesh.

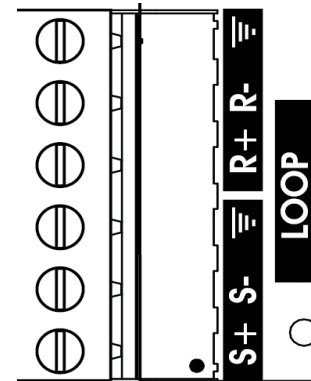
Then tape the entire cable in the shielding area so that the shielding cannot generate any earth faults.



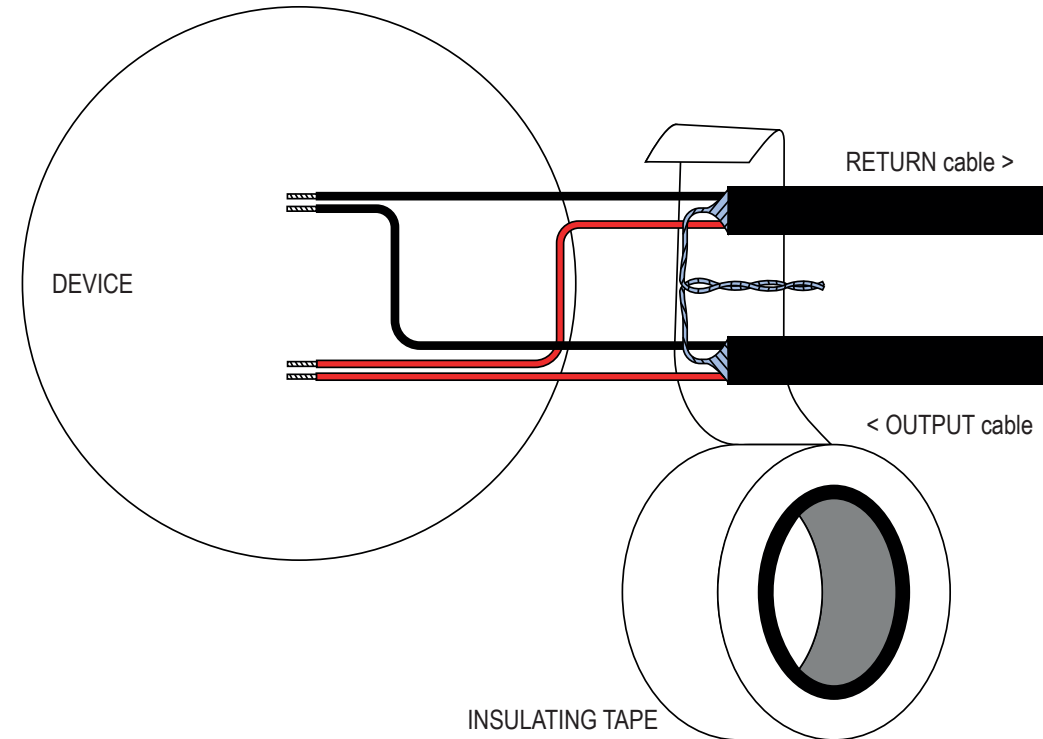

Item	Description
	Loop return mesh connection
R-	Loop return negative pole connection
R+	Loop return positive pole connection
	Loop output mesh connection
S-	Loop output negative pole connection
S+	Loop output positive pole connection



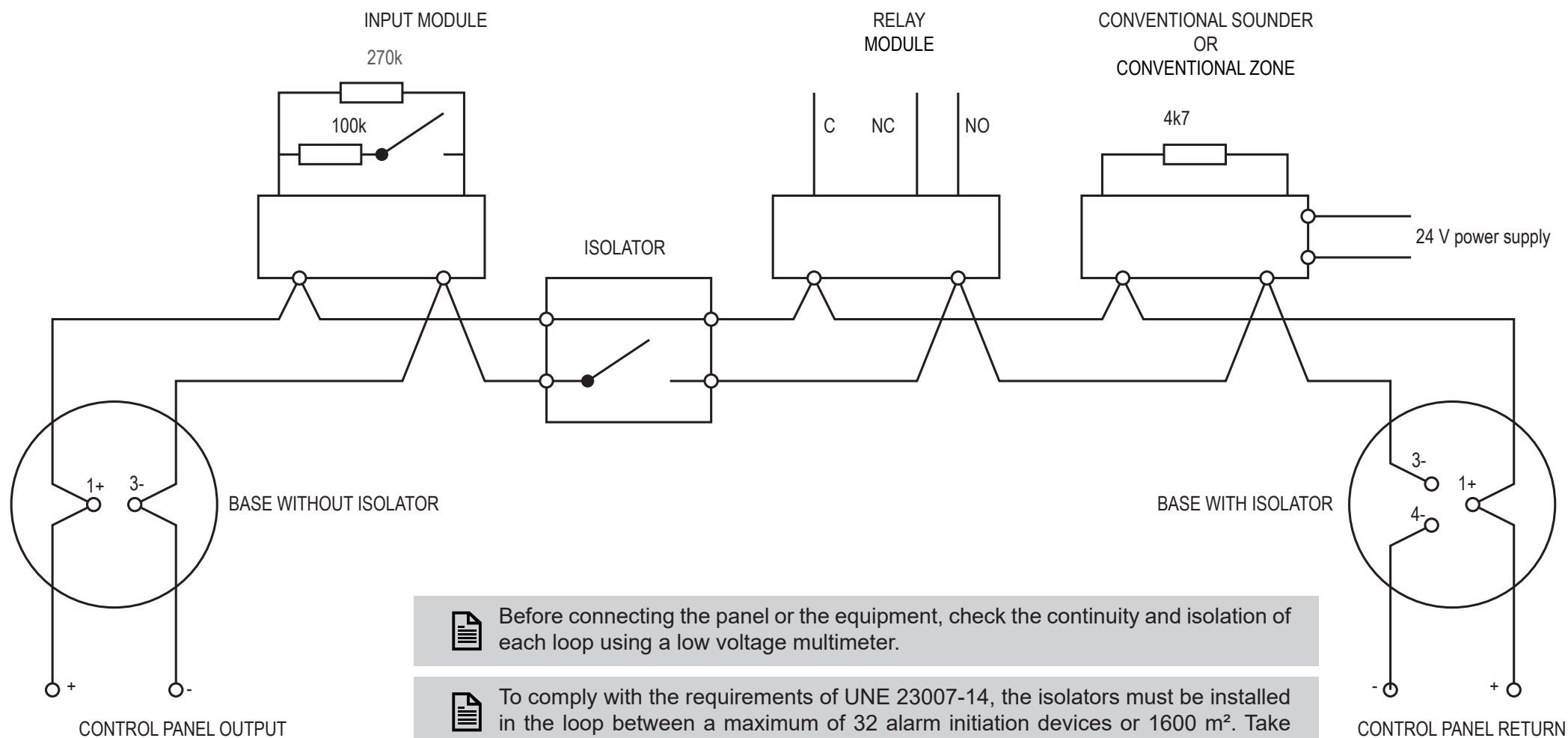

### 3.8.3. Addressable loop

The following illustration shows the typical connections of addressable and conventional equipment in an addressable loop:



 Before connecting the panel or the equipment, check the continuity and isolation of each loop using a low voltage multimeter.

 To comply with the requirements of UNE 23007-14, the isolators must be installed in the loop between a maximum of 32 alarm initiation devices or 1600 m<sup>2</sup>. Take into account that there are devices with a built-in isolator, so the installation of additional isolators may not be necessary.

 Respect the polarity when installing a device.

### 3.8.4. Checking the loop

To check the loop wiring, WITHOUT CONNECTING THE LOOP TO THE CONTROL PANEL, carry out the following steps:

**STEP 1**  
Disconnect it on the control panel

1. Disconnect the loop from the control panel at both ends.

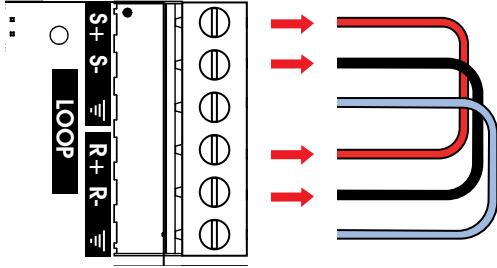

**STEP 2**  
Loop resistance test without isolators

2. If you do not use isolators and your facility does not use the connection in isolator mode, you can measure the resistance of both lines simultaneously. The measured value cannot exceed 44 ohms

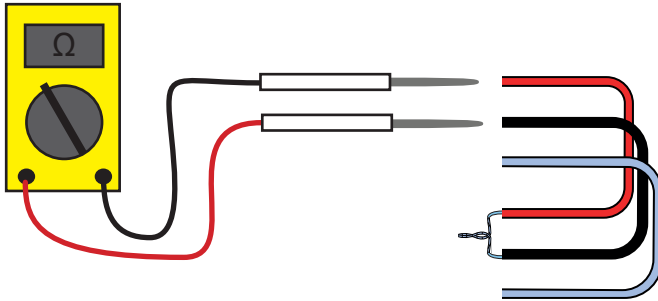

**STEP 3**  
Loop resistance test with isolators

3. If the detectors use isolators, you will only be able to measure the resistance of the positive pole. The measured value cannot exceed 22 ohms.

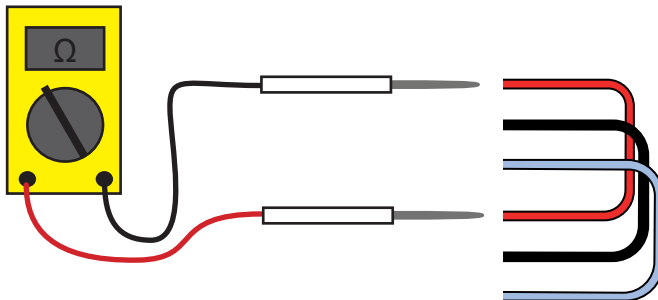

**STEP 4**  
Leakages between mesh and (+) and (-) poles

4. Use a multimeter to check that there are no leakages between the screen cable and the positive (+) of the cable or the negative (-) of the cable.

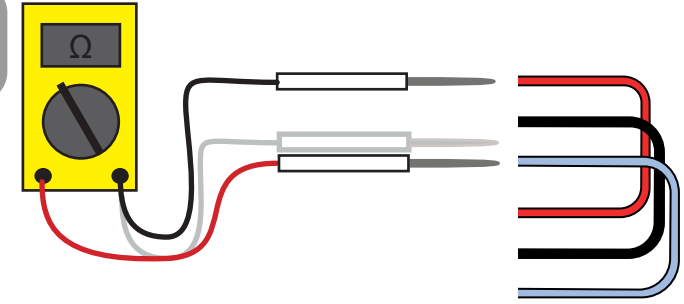

**STEP 5**  
Leakages between mesh and earth / L / N

5. If the measurement shows a resistive value of less than 1 megohm, it is possible that there is a leakage.

Check the mesh voltage with respect to the neutral or alternating voltage phase. Under no circumstances must it have voltage.

Any leakage must be resolved before continuing with the system start-up. The sectioning of the facility in sections of 50% of the run may help to effectively locate the problem.

No leakage of the mesh to earth, to the cabinet of the control panel or any other than the one established on the loop card is acceptable.

Once the previous checks have been carried out, reconnect the loop to the control panel and check that the control panel is not showing any fault.

## 3.9. SOUNDER OUTPUT

The MAIN BOARD has two sounder outputs. The sounder circuits are designed to operate with an end-of-line resistor (by default).

### 3.9.1. Connecting a polarised sounder

To connect a polarised sounder, carry out the following steps:

1. Locate the SND1 and SND2 connectors on the main board (see section 3.4).
2. Connect the + and - cables to the corresponding terminal on the MAIN BOARD.
3. Connect the sounders in parallel with the + and - cables of the main line.
4. Close the loop of 4k7 Ohms between the + and - cable at the end of the main line.



Do not forget to ALWAYS place the 4k7 ohm resistor at the end of the wiring to close the loop.

### 3.9.2. Connecting a NON-polarised sounder

If you are going to install non-polarised sounders, you must place a diode in each of the sounders in order to prevent them from sounding when the system is in standby.

To connect a polarised sounder, carry out the following steps, proceeding as in section 3.7.3 until step 2:

3. Connect a 1N4007-type diode to the + terminal of each of the sounders as shown in the drawing below.
4. Connect the sounders in parallel to the main line.
5. Close the loop of 4k7 Ohms between the + and - cable at the end of the main line.

Each output is protected with a 500 mA fuse, see section 3.4.

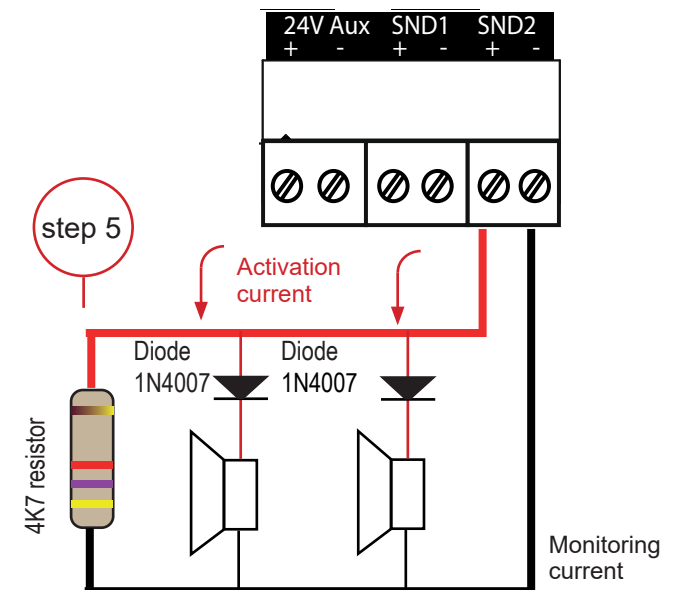
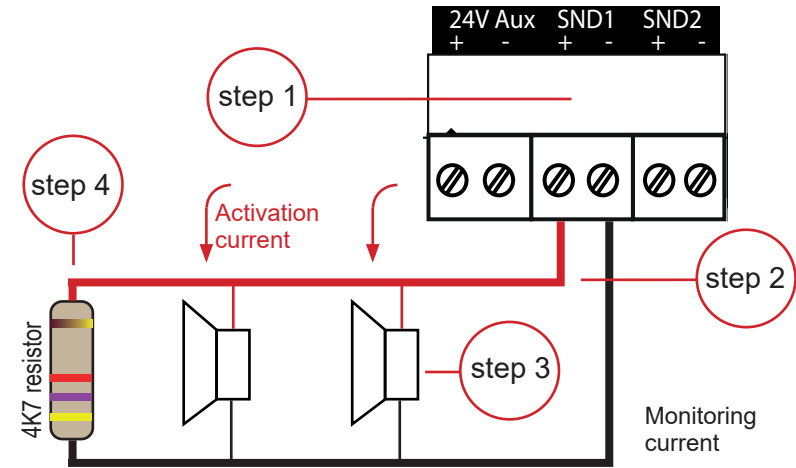

### 3.9.3. Cancelling sounder outputs

If you are going to use addressable sounders connected to the loop and you are not going to use the sounder outputs on the MAIN BOARD, carry out the following steps:

1. On the main board, locate the SND1 and SND2 connections (see section 3.4).
2. Connect the end-of-line monitoring resistor between the + and - terminals for the outputs of each sounder on the main board that you are not going to use.

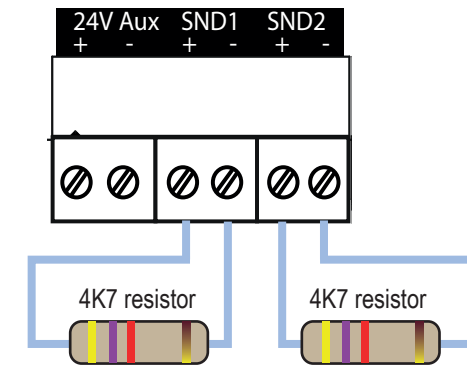

### 3.9.4. Checking the sounder line

To check the resistance of the sounder wiring line:

1. With the multimeter connected in reverse polarity, the reading should be 4k7.
2. With the multimeter connected in normal polarity, it must indicate a low value. This is due to the polarised diodes in series with the sounders.
3. Check the cable resistance to ensure activation of the sounders. The sounder circuit can provide a maximum current of 0.5 A. A resistance of more than 15 ohms could compromise the activation of the sounders.
3. Check that no voltage is diverted from the main low voltage line
4. Connect the sounder line to the corresponding SND1 or SND2 output.

The voltage output values for sounders being monitored and that are activated correspond to the following values:

$V_{snd \text{ monitoring}}$  = of -6 V to -7 V

$V_{snd \text{ activated}}$  = of 26 to 28 V

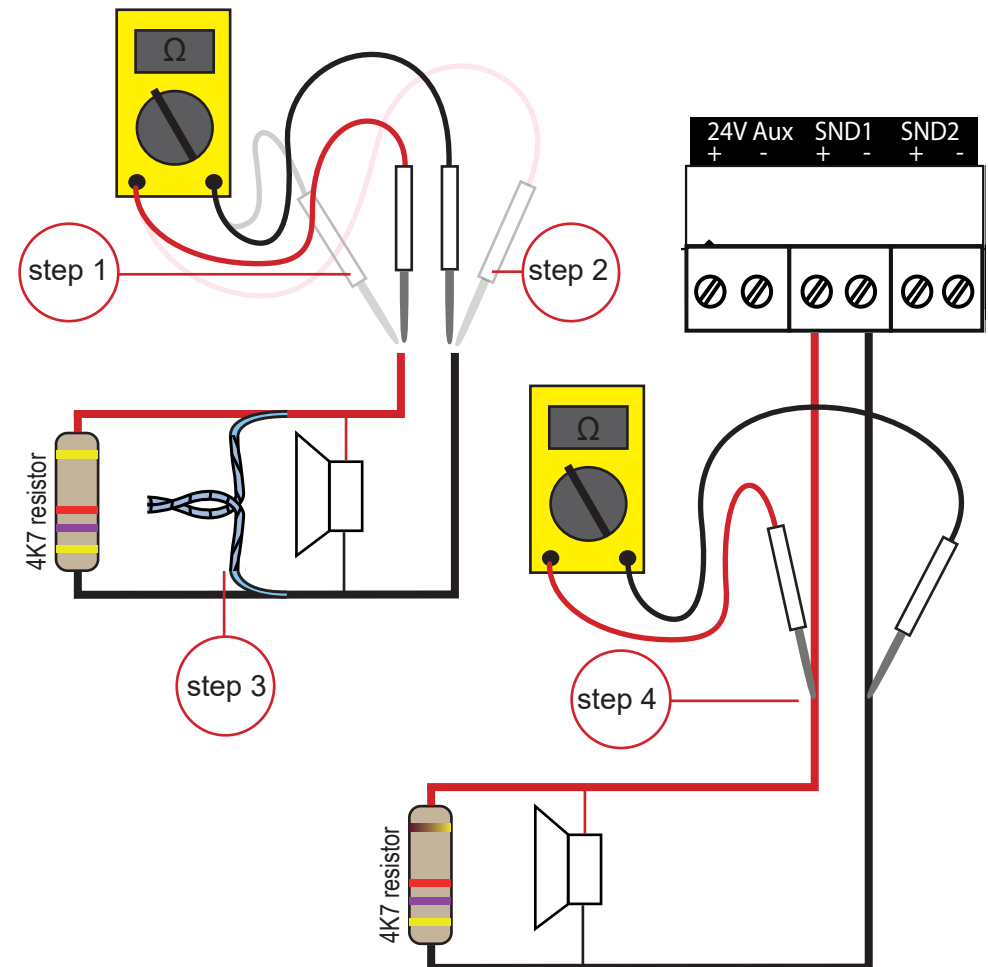

### 3.10. 24 V AUXILIARY OUTPUT

The MAIN BOARD has a 24 V AUXILIARY OUTPUT. This output can supply, for example, current to an external relay:

1. Check that:
  - the external line is not shorted or
  - earthed or diverted to any low voltage line or
  - no end-of-line elements or diodes have been connected.
2. On the main board, locate the 24 V AUXILIARY OUTPUT (see section 3.4).
3. Connect the + and - terminals to the corresponding cables. The maximum output current is 500 mA, see section 3.4 of this manual.

24 V auxiliary output

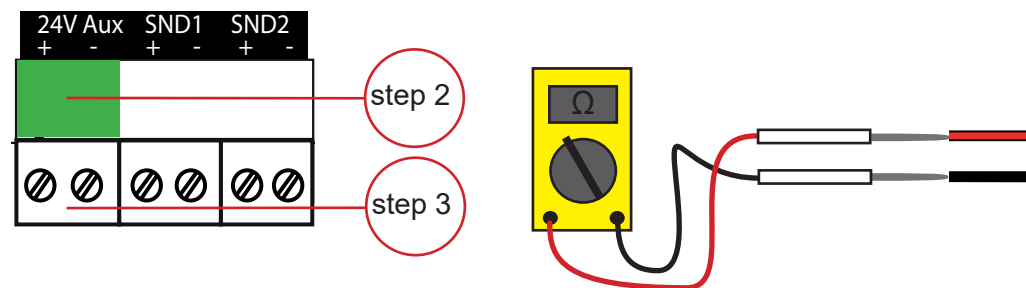



### 3.11. CONNECTING TO THE FAULT RELAY

The MAIN BOARD has a FAULT RELAY OUTPUT. This relay changes status when it detects a fault in the facility:

1. On the main board, locate the R.FAULT connector (see section 3.4).
2. Connect the main NO (Normally Open), NC (Normally Closed) and C (Common) cables to the corresponding terminals on the MAIN BOARD.

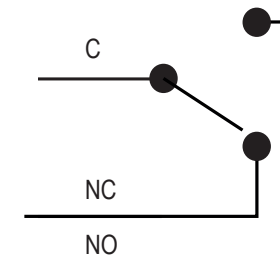
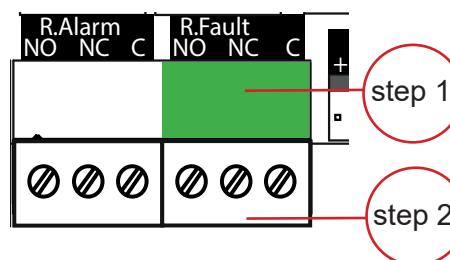
Connection to the fault relay



 The fault relay is ENERGISED. This means that, although the control panel may run out of power, both from the mains network and the battery, the relay will continue to indicate the fault status.



If you are going to use alarm or fault contacts to activate inductive loads, take the precaution of using a protection diode

### 3.12. CONNECTING TO THE ALARM RELAY

The MAIN BOARD has an ALARM RELAY output. This output activates when an alarm or an event configured as such is detected:

1. On the main board, locate the R.ALARM connector (see section 3.4).
2. Connect the main NO (Normally Open), NC (Normally Closed) and C (Common) cables to the corresponding terminals on the MAIN BOARD.

Connection to the alarm relay

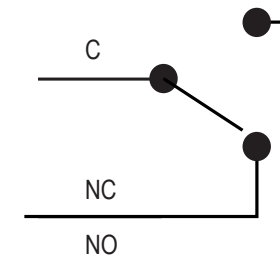
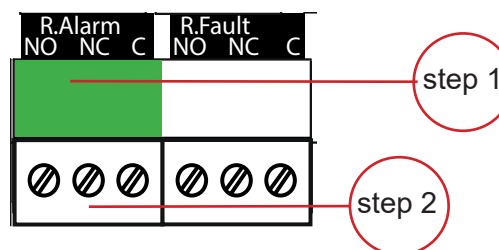



### 3.13. FINAL CONNECTION CHECKS

Before connecting the control panel to the mains network, make sure you check the following points:

**1 LOOP CONTINUITY:** Check the loop continuity with a voltmeter in case there are short circuits or points where the loop is open, as explained in section 3.7.3.

**2 CHECK THE LOOP RESISTANCE:** You can check the loop resistance by joining the R+ to R- ends and measuring via the S+ to S- ends.

The capacitance of the cable must be less than 0.5  $\mu$ F.

In normal conditions, this permits a loop length of 2000 metres with a shielded cable with a cross section of 2.5 mm<sup>2</sup> and a length of 1500 metres with a shielded cable of 1.5 mm<sup>2</sup>.

**3 END-OF-LINE RESISTOR ON THE LOOPS:** Check that the main cables of each loop have the end-of-line resistor (4k7) installed.

**4 END-OF-LINE RESISTOR ON THE SOUNDER CABLES:** Check that the main cables of the sounders connected to the MAIN BOARD have the end-of-line resistor (4k7) installed.

**5 MAIN BOARD CONNECTORS:** Check the MAIN BOARD connectors, ensuring that the cables connected to each terminal are not loose and the connectors are correctly and fully inserted.

**6 AUXILIARY OUTPUT:** Using a voltmeter, check that the voltage of the power supply is around 230 VAC and the battery voltage around 24 V.

#### 3.13.1. Use of ferrites

It is not normally necessary to use ferrites with the CAD-250 control panel.

In certain situations, it is inevitable that the loop cables pass near to power cables of industrial equipment or facilities where the recommended cables are not used. In these cases, it is advisable to install ferrites on the loop wiring.

The ferrites are installed on each cable, using one ferrite for the loop's output cable (S+ and S-) and another ferrite for the return (R+ and R-). They must be installed as near to the loop card as possible, just after the card terminal connector. The ferrite must be fixed with a cable tie.

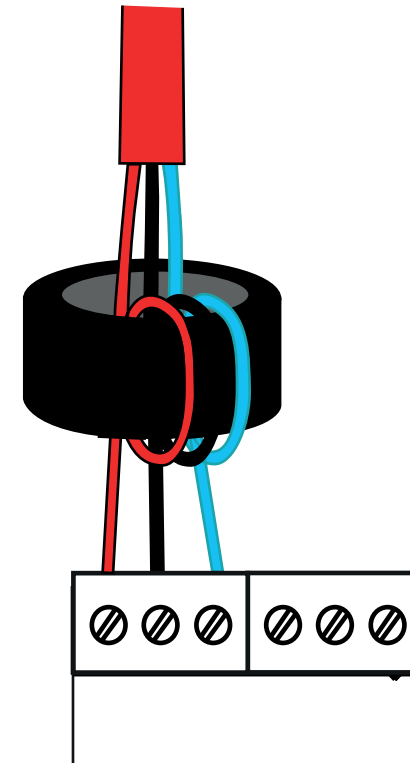

### 3.14. COMMUNICATIONS CARD (Optional)

The CAD-250 control panel permits the installation of two network card versions.

Ref.	Description
TMB-252	Network card for loop connection on CAD-250 control panels via isolated RS485 port for network connection of loop or bus control panels. Maximum distance between nodes of up to 1,000 metres
TMBFI-252	Network card for loop connection on CAD-250 control panels via fibre optic or isolated RS485 port for network connection of loop or bus control panels. Maximum distance between nodes of up to 1,000 metres

The network communications card allows you to extend the expansion possibilities for the CAD-250 control panel using the following ports (the available ports will depend on the model purchased):

No.	Ref.	Description
1	RS485 IN	Loop network connection input. Up to 64 nodes
1	RS485 OUT	Loop network connection output. Up to 64 nodes
2	RS485 MODBUS1	Not in use in applications on the CAD-250 control panel. The ModBus information will be obtained from the RJ45 connector on the main board, see the table in section 3.4
2	RS485 MODBUS2	Not in use in applications on the CAD-250 control panel. The ModBus information will be obtained from the RJ45 connector on the main board, see the table in section 3.4
3	RS232	Connection port for compatible devices. Future application
4	OUT RX TX	Loop network fibre optic output. Up to 64 nodes.
4	IN RX TX	Loop network fibre optic input. Up to 64 nodes.
5	RJ45	Not in use in applications on the CAD-250 control panel. The ModBus information will be obtained from the RJ45 connector on the main board, see the table in section 3.4

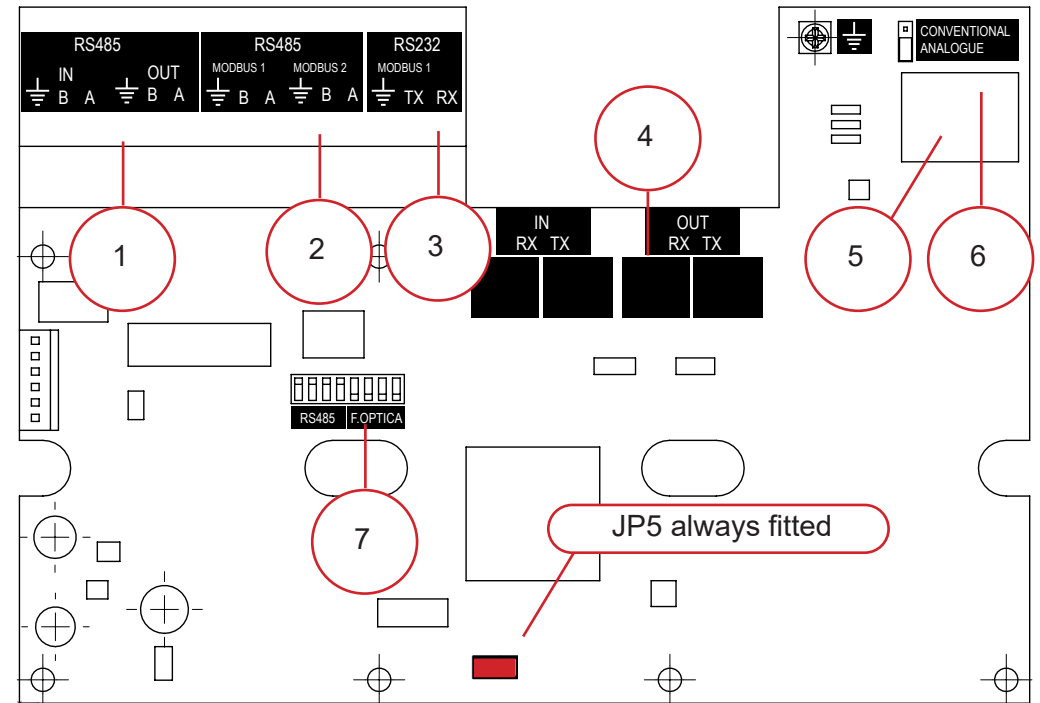

No.	Ref.	Description
6	CONVENTIONAL ANALOGUE	Control panel mode selection jumper. The lower jumper must always be connected in applications with CAD-250
7	RS485 / F.OPTICA	Dip Switch for mode configuration of the network input and output wiring

#### Installing the optional network card



If the control panel is connected to the mains network, put the differential lever into disconnected position (down) and disconnect the battery terminal (see section 3.5) to guarantee that no electrical flow reaches the control panel.

1. Locate the location for inserting the network card. (See section 3.4). It is assembled on the supply protection board with the help of 5 threaded spacers located on the power supply support.

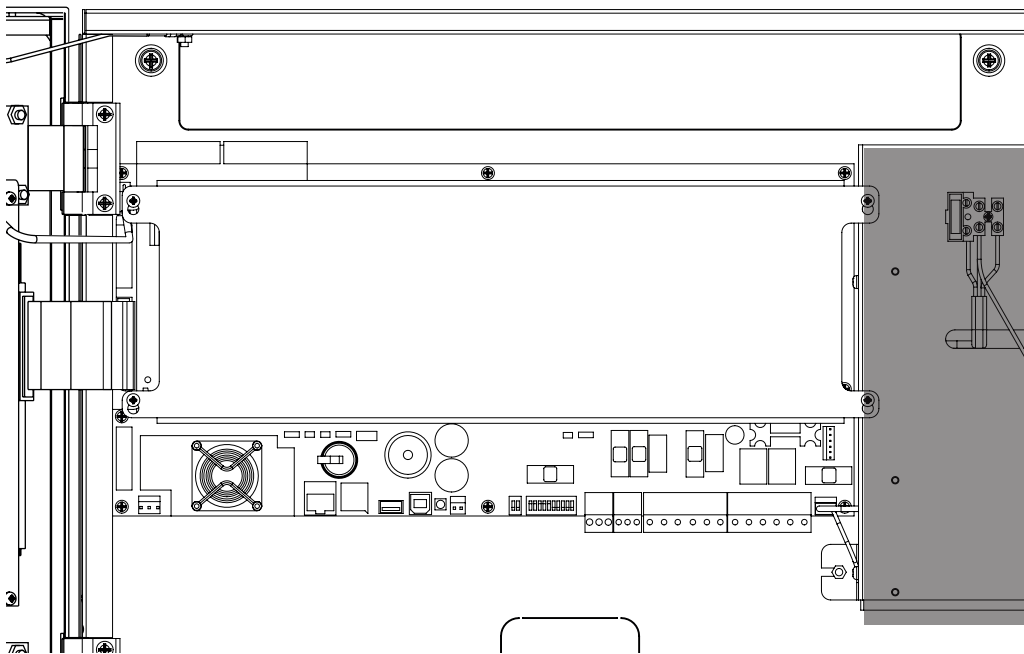

2. Locate the network card connector on the main board. See entry 28 in the table in section 3.4.

3. Secure the board with the 5 screws provided.

4. Connect the expansion cable, supplied with the network card, to the main board connector.



To install the network card, it is not necessary to remove the main board protection (see section 3.3), although you will find it easier to connect the card if you do remove it.



Only use the NYLON SCREWS supplied with the loop card to prevent any damage to the electronics, as metal screws can cause short circuits.

5. Connect the other end of the cable to the communications card.

Once the card is installed, connect the corresponding terminals and activate it, via the configuration menus, so that the control panel recognises it and you can thus access the new communication options of your control panel.

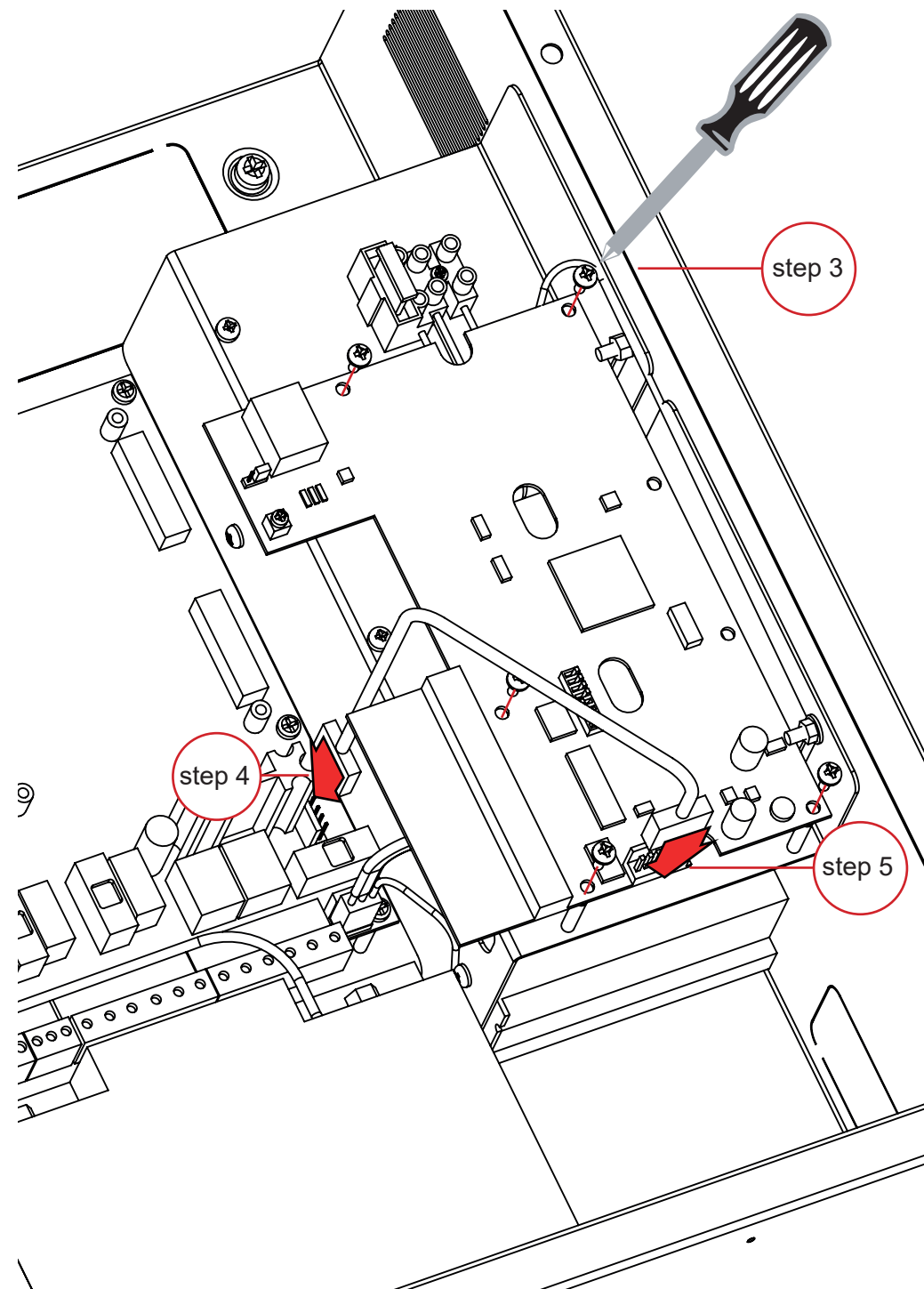





## Configuration table of inputs and outputs for the loop network

The architecture of networked control panels of the CAD-250 control panel must be a continuous loop; this is a requirement that may also be required by national or local regulations, e.g. EN54 13.

The network permits the use of the connection between nodes as follows:

- via standard cable for RS485
- via multimode fibre optic
- a combination of both

Conf	Description
 RS485   F.OPTICA	1 - 2 ON =>IN RS485 ON 3 - 4 ON =>OUT RS485 ON 5 to 8 OFF =>F.OPTICA OFF
 RS485   F.OPTICA	1 - 2 ON =>IN RS485 ON 3 - 4 OFF =>OUT RS485 OFF 5 - 6 ON =>OUT F.OPTICA ON 7 - 8 OFF =>IN F.OPTICA OFF
 RS485   F.OPTICA	1 - 2 OFF =>IN RS485 OFF 3 - 4 ON =>OUT RS485 ON 5 - 6 OFF =>OUT F.OPTICA OFF 7 - 8 ON =>IN F.OPTICA ON
 RS485   F.OPTICA	1 - 2 OFF =>IN RS485 OFF 3 - 4 OFF =>OUT RS485 OFF 5 - 6 ON =>OUT F.OPTICA ON 5 - 6 OFF =>IN F.OPTICA ON

### Cable connection



Do not use multipair cables, as their use contravenes the installation recommendations set out in UNE 23007-14 and may significantly reduce the maximum installation length between nodes due to capacitive effect.

The accepted maximum length between nodes with standard cable is 1000 m.

The use of standard shielded cable is only accepted for data with a characteristic impedance of 120 ohms.

We recommend the use of a standard cross section of 1.5 mm<sup>2</sup>.

The connection between nodes must respect the polarity and input and output criteria for each node. From the output connector of a node to the input connector of the following node. From terminal A of the output node to terminal A of the input node.

Make sure you have correctly selected the position of the configuration mini switches. See table in annex.

### Fibre optic connection

- Connector type: ST
- Fibre type: Multimode
- Wavelength: 820 nm
- Standard colour of the fibre sleeve: orange
- Maximum length: 1,000 m

Fibre networks are immune to electromagnetic interference, so they are ideal for industrial environments, infrastructures, and in general, where a high incidence of electrical noise is expected or it is impossible to avoid transmission lines passing close to noise sources.

Although fibre links perform very well in electromagnetic noise environments, this type of link is not immune to distortion or loss of the signal. Take into account the losses in hoses, fibre welds, connectors and/or quality of the fibre itself.

Fibre type	Max.	Typical
Optical Power Budget with 50/125 µm fibre	18.8	15.8
Optical Power Budget with 62.5/125 µm fibre	15	12

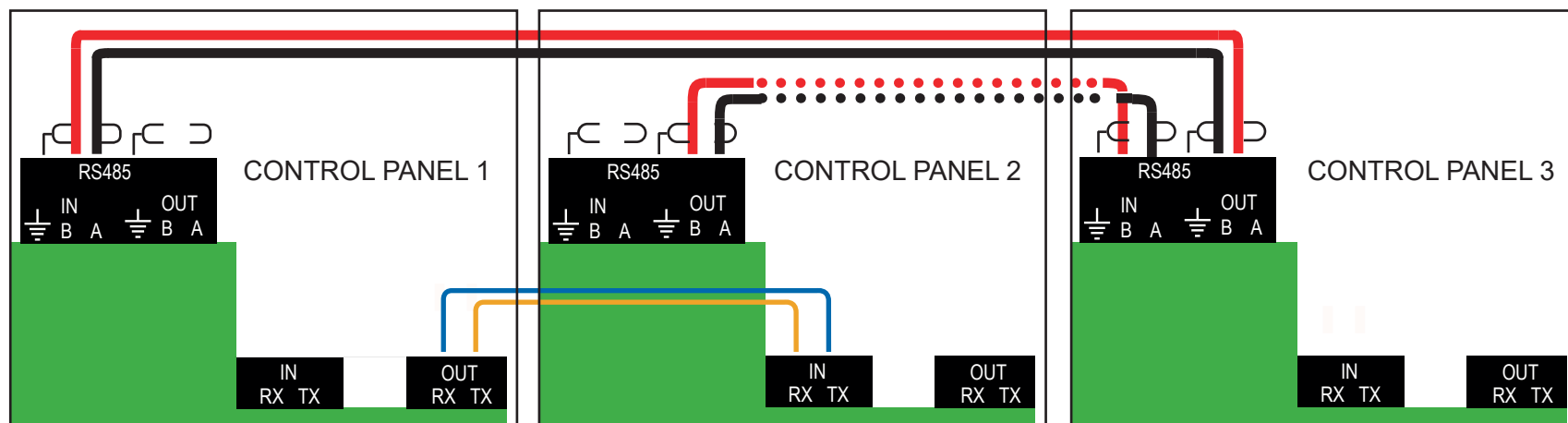
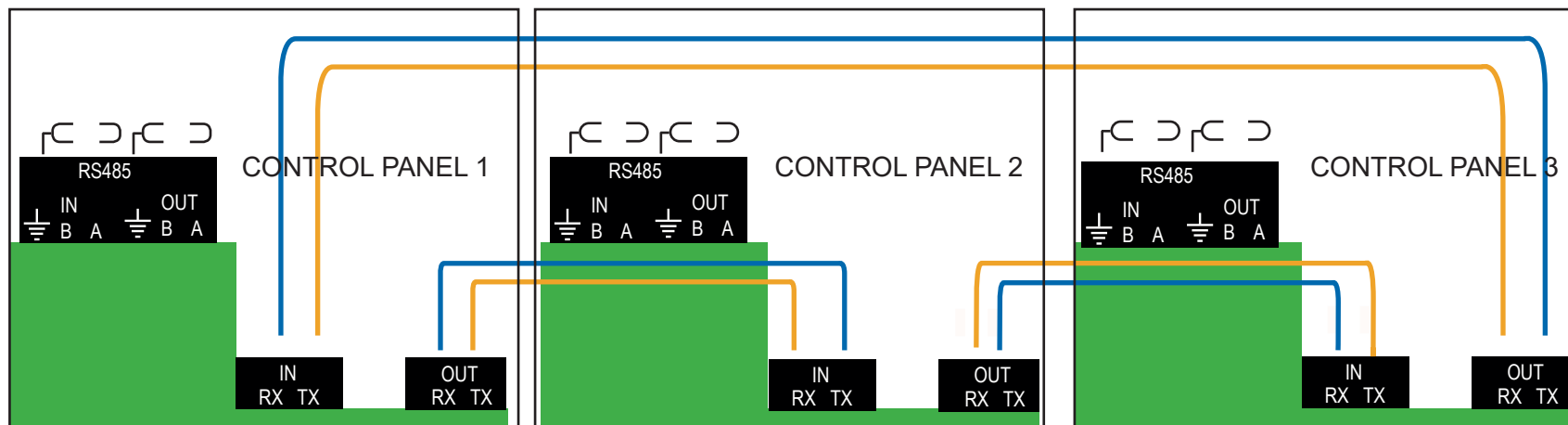
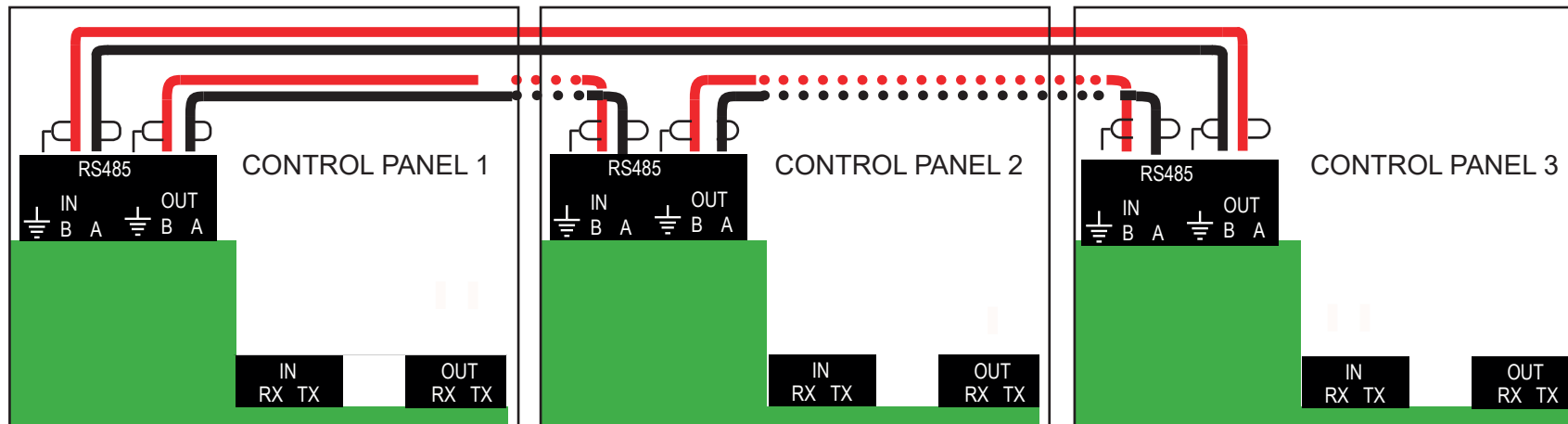

## 4. START-UP

### 4.1. MAIN PANEL

The main panel is located on the left part of the door and consists of a series of lights and basic controls that let you know what is happening in the system at a glance.

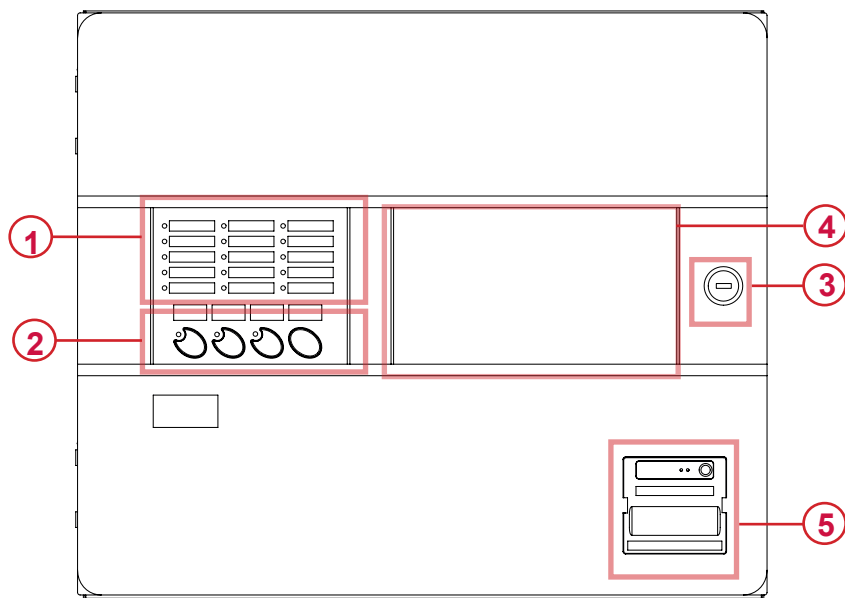

### 4.2. GENERAL LEDS

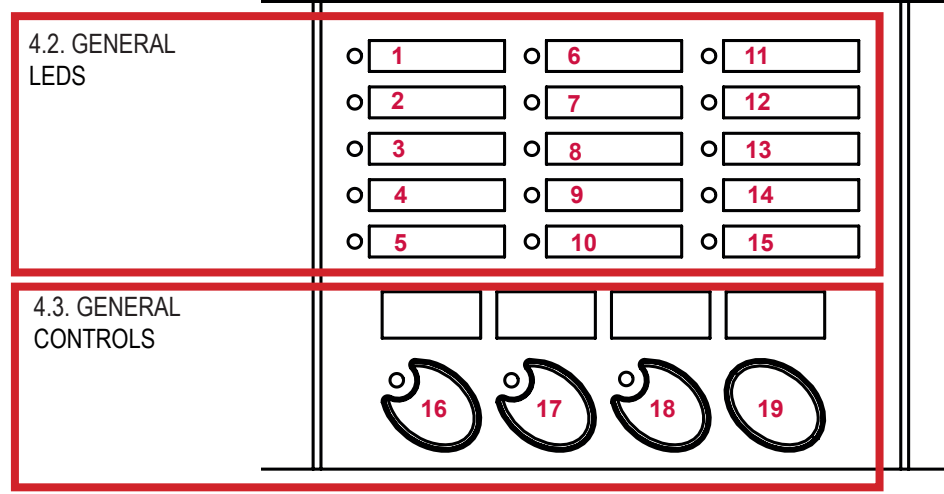

No.	Condition	Colour/ status	Description
1	SERVICE	Green Permanent	The control panel is powered and works correctly
2	ALARM	Red Permanent	The fire alarm condition is active from any initiator device in the loop
3	CANCEL	Amber Permanent	An element of the system is disabled (device, group, etc.) or there is a delay applied. Normally active together with another general indicator
4	FAULT	Amber Intermittent	Indicates a fault in the system from a loop element, communication ports or the control panel; normally active in combination with other general indicators
5	TEST	Amber Permanent	An element of the system, area or zone is in test mode.
6	OUT OF SERVICE	Amber Permanent	There is a mains network power failure and the battery voltage is less than 20 V.
7	SYSTEM FAULT	Amber Intermittent	There is a power supply issue caused by the network, batteries or fuses







The European standard EN54-2 sets out the requirements for this panel, including the buttons, visual and audible indications and their behaviour.

No.	Area	Description
1	GENERAL LEDS	General state indicators in accordance with the UNE 23007-2 and EN54-2 requirements
2	GENERAL CONTROLS	Mandatory general control buttons in accordance with the UNE 23007-2 and EN54-2 standards.
3	LOCK	Permits or blocks access to the inside of the control panel. (Acts as access level 3).
4	10" TOUCHSCREEN	Main interface of the CAD-250 control panel.
5	PRINTER	Only available on CAD-250-P: It allows you to obtain a paper copy of the system's events. This device cannot be installed as an option.

No.	Condition	Colour/ status	Description
8	POWER SUPPLY FAULT	Amber Permanent	Critical system fault. In this case, the system is not operative.
9	EARTH LEAKAGE FAULT	Amber Intermittent	Some of the system lines are earthed directly or indirectly.
10	RESERVED 1	Amber	Programmable indicator for customisable function
11	TIMED SOUNDERS	Amber	Programmable indicator for customisable function
12	FAULT/ CANCELLED SOUNDERS	Amber Permanent	Programmable indicator for customisable function
13	OUTPUTS CANCELLED	Amber Intermittent	Indicates that there is a fault in the sounder circuit or in a loop sounder
14	RESERVED 2	Amber Permanent	Indicates that there is a control element or relay disabled on the main board.
15	RESERVED 3	Amber	Programmable indicator for customisable function.

### 4.3. PRIMARY CONTROLS

No.	Function	Symbol	Description
16	ACTIVATE SOUNDERS		Press the button to activate the sounders. EVACUATION
17	SILENCE SOUNDERS		Press the button to silence the sounders. The sounders will be reactivated if a new alarm event arrives.
18	RELAYS DISABLED		Press the button to silence the acoustic signal of the control panel. The signal reactivates when a new event is received.
19	RESET		Press to reset the system. All alarm and fault conditions, as well as all control activations will be reset. If the incidents persist, the activation and operating process will be reactivated again.

### 4.4. INITIAL START-UP

If you followed the initial steps of this guide, a GREEN LIGHT will light up on the left part of the door (MAIN PANEL) and the screen will show:

a. A status bar that indicates that the control panel is starting up, please wait.

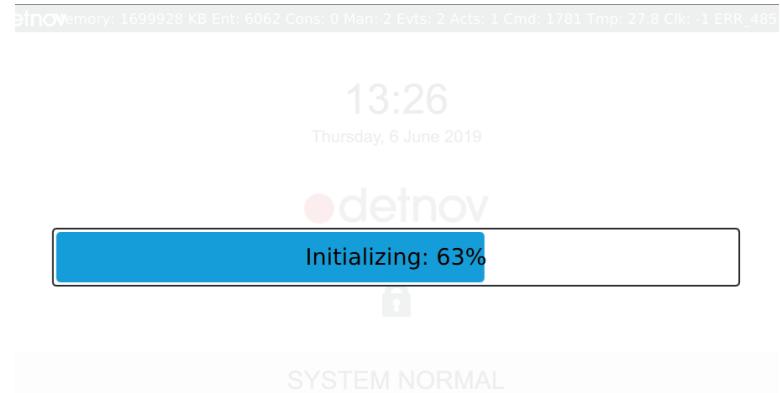

b. The STANDBY SCREEN will appear, which shows the basic control panel information.

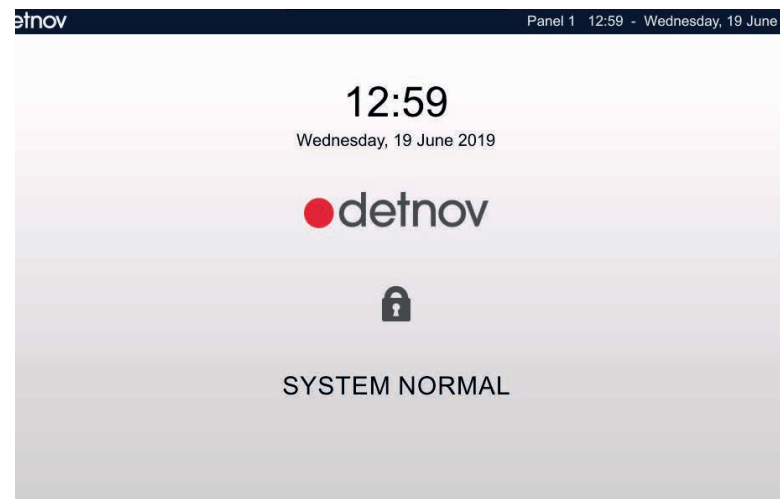



## 5. QUICK CONTROL PANEL CONFIGURATION

The purpose of this section is to carry out a simple initial start-up by configuring basic parameters for both the control panel and the elements (devices, loops, networks), so that you can check the correct operation of the panel and the facility.

If you would like detailed information on how to use and configure the control panel, please consult the Advanced Configuration Guide.

### 5.1. ADMINISTRATOR ACCESS

Once the system has started up, you will see the following screen, called the STANDBY SCREEN.

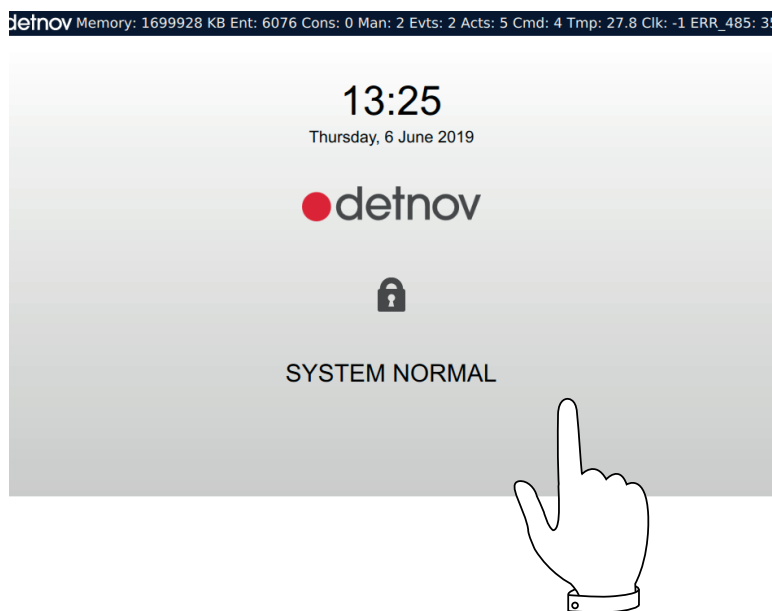

This screen shows the time and date in the UPPER BAR, the CONTROL PANEL NAME and a padlock.

This screen will remain provided if the system does not detect any event (alarm, fault or technical event).

Touch the touchscreen with your finger over the padlock icon (🔒). By doing so, you will access the ACCESS SCREEN, requesting the access code and password.

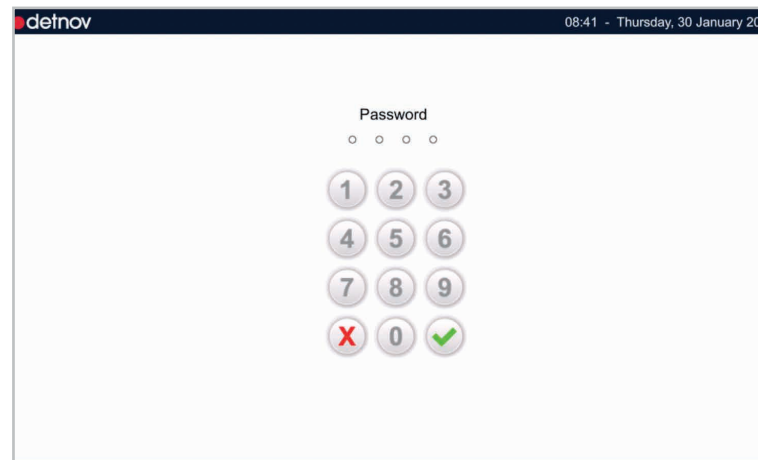

Depending on the password entered, certain configuration parameters will not be available to prevent improper use of the system.

Make sure you have the necessary authorisation and knowledge to operate this control panel as an administrator, otherwise do not use this level without the supervision of an authorised person.

**⚠️ WARNING!** The improper or negligent use of the access level with ADMINISTRATOR PRIVILEGES may cause a malfunction of the facility that can cause the loss of human lives.

Enter the administrator password by default, **2222**



## 5.2. ADMINISTRATOR SCREEN

The administrator screen is divided into 6 different sections:

No.	Name	Posit.	Description
1	MAIN MENU	Left	Categorises the sections. Loops - Sectors - Manoeuvres - Log - Network - Configuration - Engineering - Maps
2	SUBMENU	Right	Classifies the options for each menu section. It is different for each section.
3	NAVIGATION BAR	Top center	Browsing elements; they may be TABS, ARROWS or BUTTONS.
4	MAIN VIEW	Center	Information relating to the chosen menu. It allows the editable fields to be modified via a virtual keyboard. It can show ELEMENT LIST: Ordered in list form. Their features are shown when you press on them. CONFIGURATION TABLE: It shows the information in a table, some of these fields can be editable. GRID: It shows devices in a grid, as well as any value or feature. TREE: It shows Areas, Zones and/or Elements in a tree, as well as any modifiable value or feature. FLOATING WINDOW: It can be shown within the main screen, allowing various actions to be consulted or carried out.
5	STATUS BAR	Top	It shows general information, such as the description of the control panel, the time and date.
6	MESSAGE BAR	Bottom	It shows contextual messages depending on the selected section.

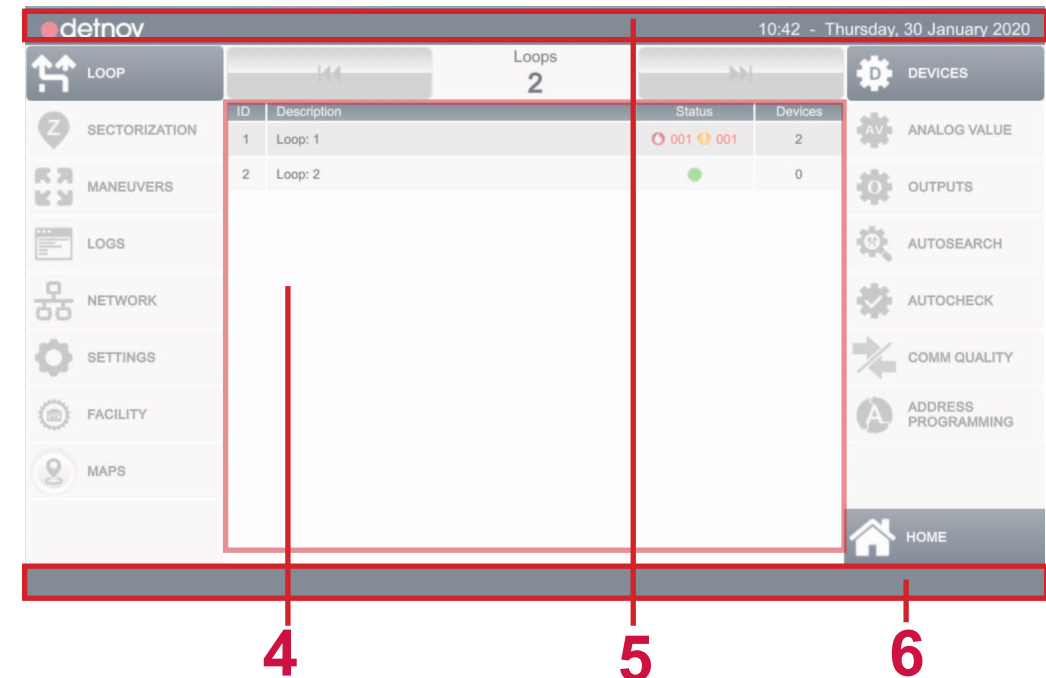
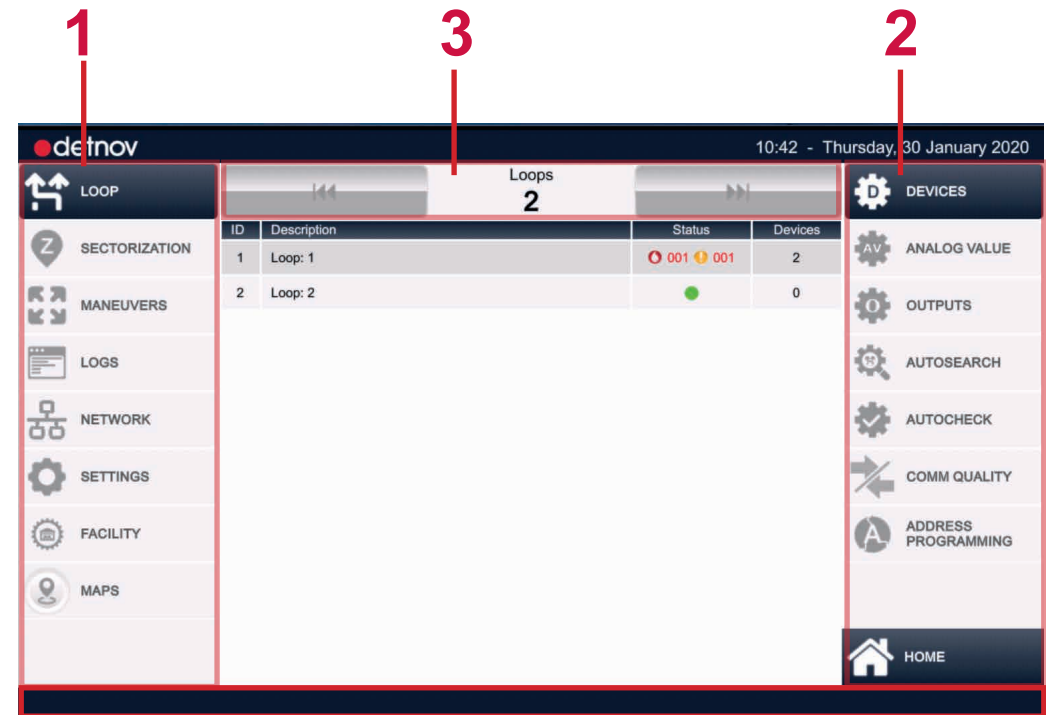

### 5.3. CONFIGURATION

In this section, you will be able to establish basic configuration parameters for the control panel. To access these settings, press:

**SETTINGS** (Main menu) > **GENERAL** (Submenu)

#### 5.3.1. Control panel description

**SETTINGS** (Main menu) > **GENERAL** (Submenu) > **MISCELLANEOUS** (Tab)

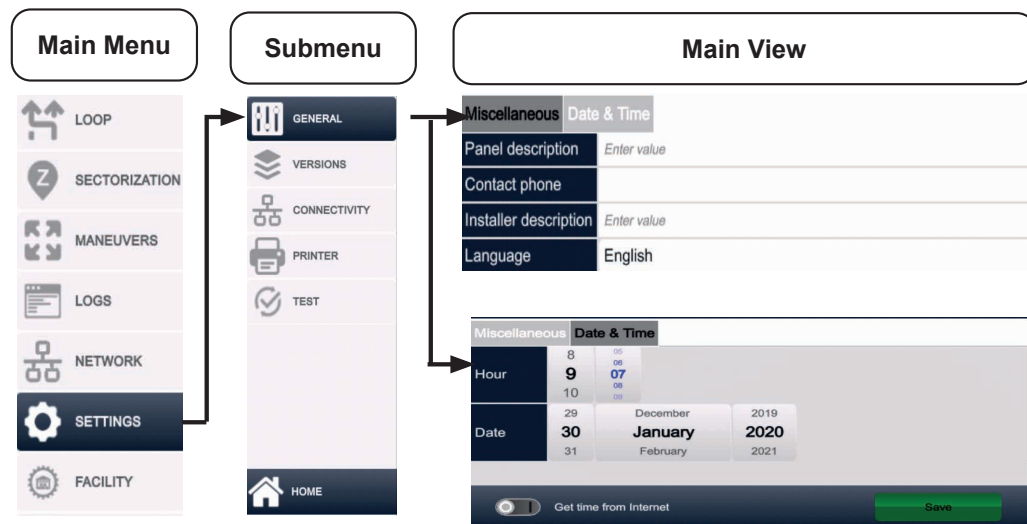

This field defines the name of a control panel in the facility.

Default value: **Panel 1**.

To modify it, select the **Panel description** field and a virtual keyboard will appear.

Press ENTER to finish editing and save the data automatically.

#### 5.3.2. Contact phone

**SETTINGS** (Main menu) > **GENERAL** (Submenu) > **MISCELLANEOUS** (Tab)

The contact phone will be shown in the EVENT MANAGER (see section 7.3) when a FAULT is detected.

To modify it, select the **Contact phone** field and a virtual keyboard will appear.

Press ENTER to finish editing, the data will be saved automatically.

#### 5.3.3. Installer information

**SETTINGS** (Main menu) > **GENERAL** (Submenu) > **MISCELLANEOUS** (Tab)

This information will be shown in the EVENT MANAGER when a FAULT is detected.

To modify it, select the **Installer description** field and a virtual keyboard will appear. Press ENTER to finish editing, the data will be saved automatically.

#### 5.3.4. Language

**SETTINGS** (Main menu) > **GENERAL** (Submenu) > **MISCELLANEOUS** (Tab)

It allows the language of the control panel to be changed. To change the language, select the **Language** field and a drop-down menu will open; select the required option, the interface language will change to the selected language and it will return to the STANDBY screen.

Default value: **English**

#### 5.3.5. Date selection

**SETTINGS** (Main menu) > **GENERAL** (Default submenu) > **DATE AND TIME** (Tab)

This section defines the time and date of the control panel, which will be used when manoeuvres are programmed.

If the system is connected via the RJ45 port to an Ethernet network with Internet access, it is possible for the time to be updated automatically; for this, activate the option:

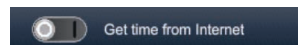

Press , **SAVE** to update the settings.



## 5.4. LOOP AUTOSEARCH

When starting the system up for the first time, it should recognise the devices installed in the loops. You can perform this action automatically via the LOOP AUTOSEARCH feature.

LOOP (Main menu) > AUTOSEARCH (Submenu)

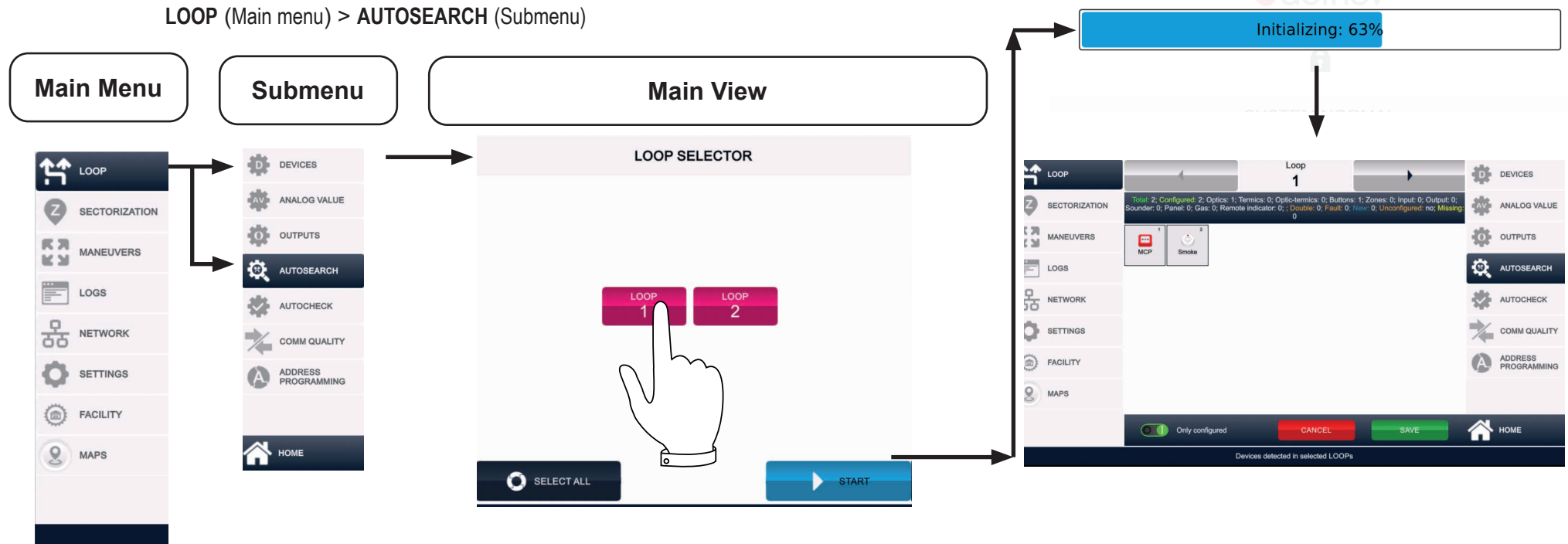

The main view will show the loops installed in the control panel. Select the loops that you wish to synchronise; when you do this for the first time, you should select them all.

Press **START**, **START** to begin the search process.

Alternatively, the button **SELECT ALL** lets you select all the loops or delete the entire selection.

A progress bar will be shown in the main view.

When the process is complete, the view will show the result of the devices found in each loop, once completed, the main view will show the devices found for each loop with detailed information of each type under the navigation bar.

Use the cursors to view all of the devices found

Press **SAVE**, **SAVE** to update the database.

Press **CANCEL**, **CANCEL** to undo the proposed changes.

The **Only configured** switch lets you limit the display to the elements found after the search. If the option is deactivated, it will show all possible addresses for each loop.

### 5.5. DEVICES

In this submenu, you can configure the devices connected to a loop individually.

LOOP (Main menu) > DEVICES (Submenu)

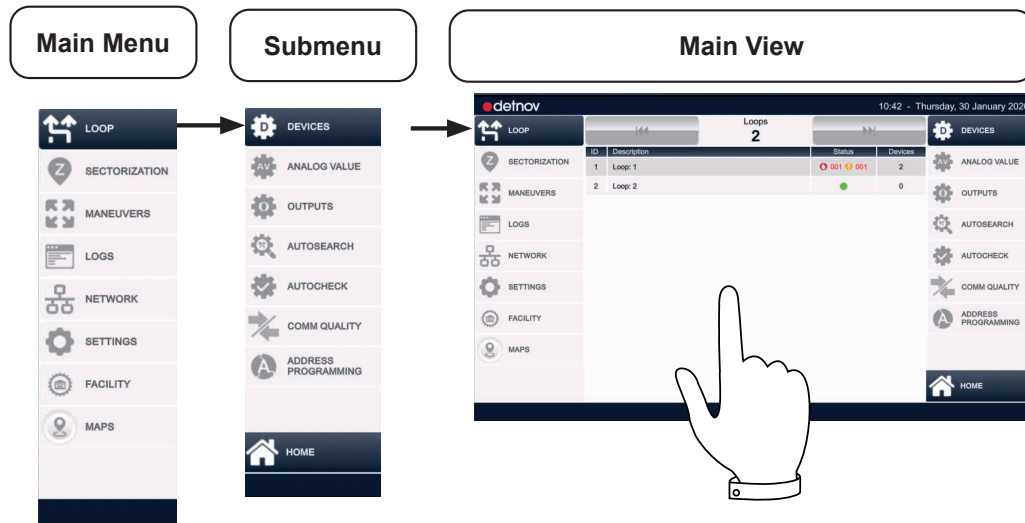

Until you manually enter the devices in the system or you carry out an autosearch, the device list will appear empty.

From the navigation bar and with the help of the [left] [right] buttons, you can skip and view the device lists for each loop installed.

Under the navigation bar cursors are the status filter buttons. By touching the filter option, the device list will be limited to those whose condition matches the selected filter:



**ALARM:** Devices in fire alarm condition. They may be detectors, manual call points or inputs configured as fire zones. It shows the number of elements in this condition.



**FAULT:** Devices in fault or failure condition.



**TECHNICAL:** Supervised inputs that are not considered alarms. They can only be the input modules.

To see the device LIST in each loop:

Press Loop (n) > Device list

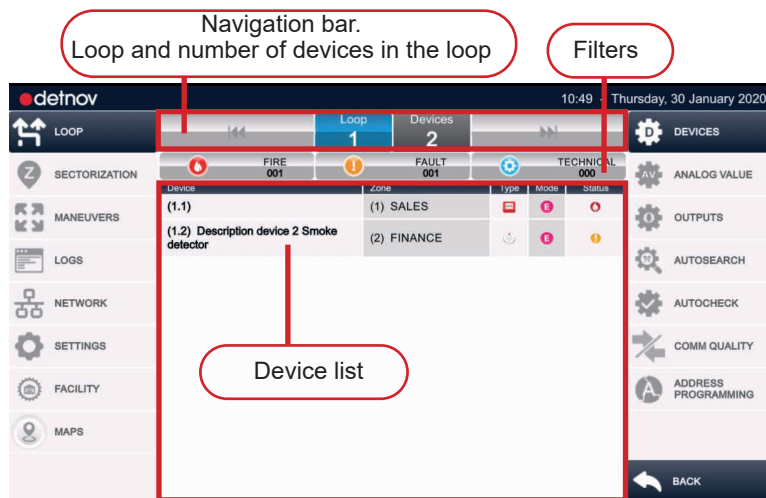

### 5.5.1. Device information and configuration

From the device list and when selecting one of them, you will have access to its detailed fields, which will allow you to consult or configure its operation.

The navigation bar identifies the loop number and device that you are in currently.

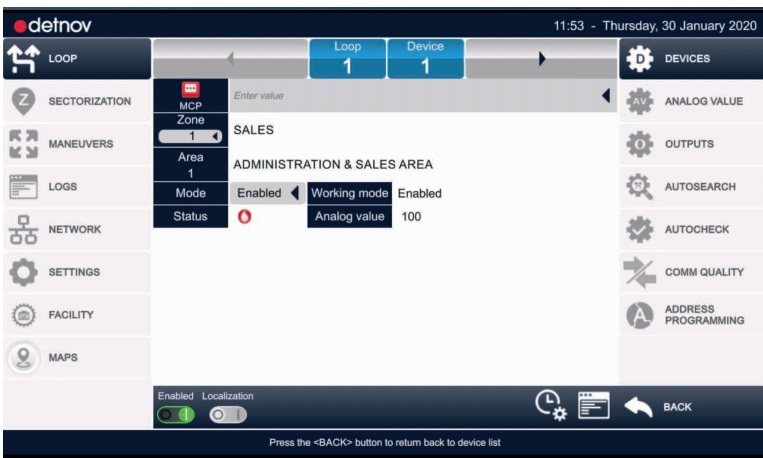
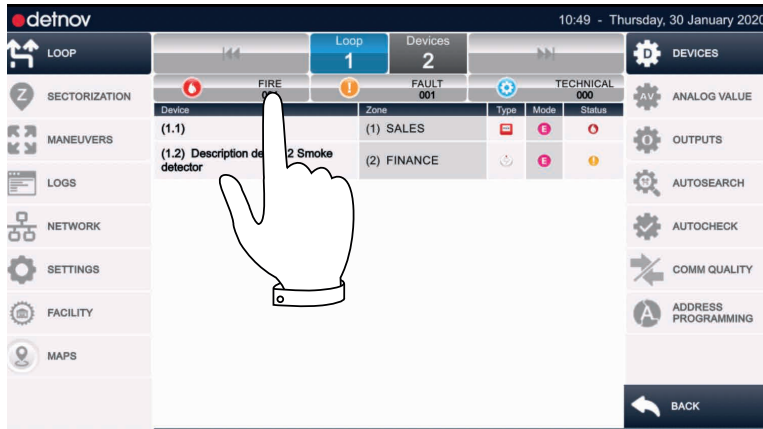

Descriptive term	Definition
DEVICE	Identified by the loop number and physical address of the device. The device description is also shown here when it is assigned. To change the description, touch the description field and a virtual keyboard will appear
ZONE	It shows the zone assigned to the device. By default: <b>Zone 1</b> . It shows the description of the zone if it has been assigned To change the zone assignment, touch the Zone field and a virtual keyboard will appear; enter the corresponding zone number. If the chosen zone number does not exist, the zone will be created automatically.
AREA	It shows the area assigned to the device. By default: <b>Area 1</b> . It shows the description of the zone if it has been assigned To change the area assignment, touch the Area field and a virtual keyboard will appear If the chosen area number does not exist, the area will be created automatically.
TYPE	It identifies the type of device found or assigned. Detector, manual call point or module.
MODE	It indicates the <b>ZONE</b> or <b>AREA</b> mode to which the device is assigned. This field can only be modified from the <b>SECTORISATION</b> section of the main menu. The modes of a zone or area can be <b>ENABLED</b> , <b>DISABLED</b> or <b>TEST</b>
STATUS	Condition of the device: Green: Normal or in standby Red: Alarm Amber: Fault Blue: Technical event active
ADDRESSABLE VALUE	It shows the analog value corresponding to the device status and the sensor reading at that time

By pressing **Loop** on the navigation bar, a pop-up table will open, giving you the option to change the loop selection.

By pressing **Devices** on the navigation bar or the back button, you will return to the device list.

## 5.6. SECTORISATION

From the SECTORISATION section on the main menu, it is possible to create, review and modify the sectorisation tree.

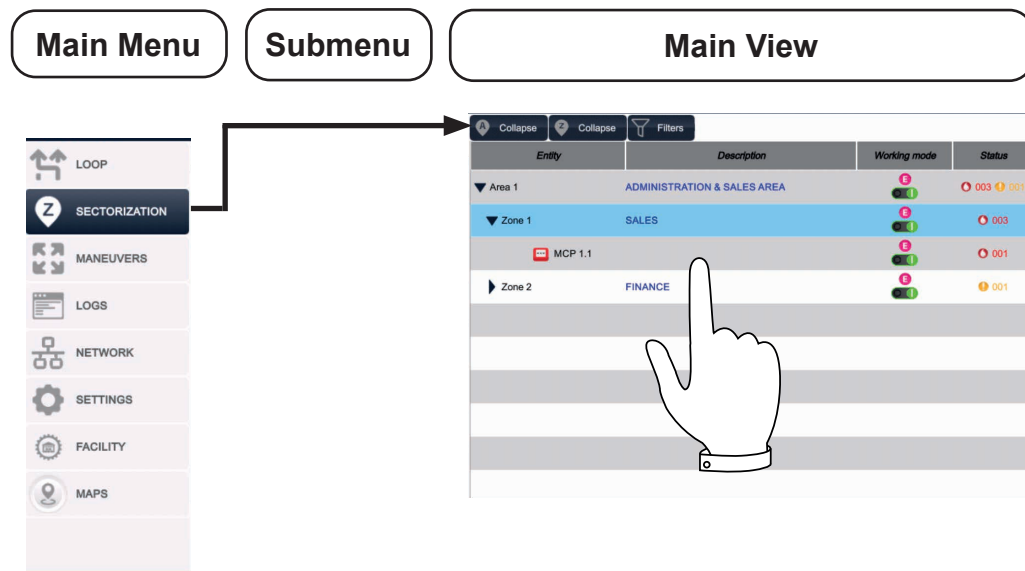

### INTRODUCTION TO SECTORISATION:



One of the fundamental design principles of a fire detection system is the division of the facility into areas and zones, with the aim of monitoring the indication of events and alarm inputs. The zones allow better organisation of the devices in the facility, whether they are installed in the same loop or not. This also allows you to change the working mode of these locations (AREAS or ZONES).

There may be limits established by local regulations for the definition, scope and coverage of the zones. Consult the project and local standards, for e.g. UNE 23007-14, as well as any sector regulations that may be applicable

Just like with the devices, it is possible to establish working modes for ZONES/AREAS from the SECTORISATION section of the main menu.

**ENABLED:** the devices and their events are taken into account.

**DISABLED:** the devices in this zone/area are ignored.

**TEST:** useful for carrying out maintenance tasks without the alarm going off.

The modes establish the behaviour according to a hierarchical structure whereby the AREA is superior to the ZONE and this is superior to the DEVICE.

The behaviour due to the WORKING MODE of an AREA will affect the ZONES and the DEVICES of each one, but this does not happen the other way round.

If an AREA is DISABLED, the ZONES contained by that AREA will be also, as will the DEVICES contained by those ZONES.

If a ZONE is DISABLED, the devices contained within that ZONE will be also, though the AREA that contains them will not.

If you DISABLE a DEVICE, this does not disable the ZONE or the AREA that contains it.

Similarly, when you enable an upper hierarchy, the lower hierarchies will only be disabled if they have not been individually configured in DISABLED mode.

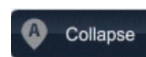

It allows the sectorisation tree of the Area upper hierarchy to be collapsed or expanded.

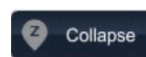

It allows the sectorisation tree of the Zones hierarchy to be collapsed or expanded.

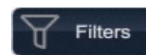

It allows view filters to be applied by type, description, mode or status.

Entity	Description	Working mode	Status
Area 1	ADMINISTRATION & SALES AREA		003  001
Zone 1	SALES		003
MCP 1.1			001



The following elements are identified on the segmentation tree:

Field	Definition
ENTITY	Area, Zone or individual device
DESCRIPTION	Alphanumeric definition assigned for each entity. Up to 54 characters.
WORKING MODE	Normal, Enabled or Tests. It is possible to modify the mode from the segmentation tree. In doing so, the mode of the lower hierarchy entities will also change.
STATUS	Condition of the device: Green: Normal or in standby Red: Alarm Amber: Fault Blue: Technical event active

When selecting each tree line, a pop-up screen will be shown that will allow you to review and edit according to the needs of the project.

In this initial start-up, all elements will be individually assigned to area 1 and zone 1.

When selecting an area line, the pop-up menu will allow you to view:

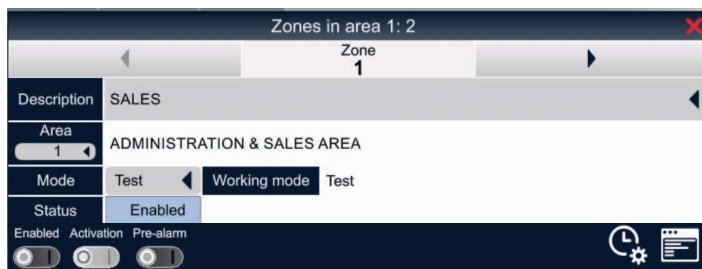

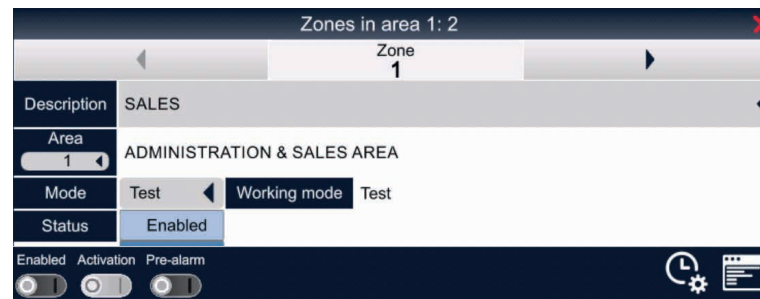

When selecting a zone line, the pop-up menu will allow you to view:

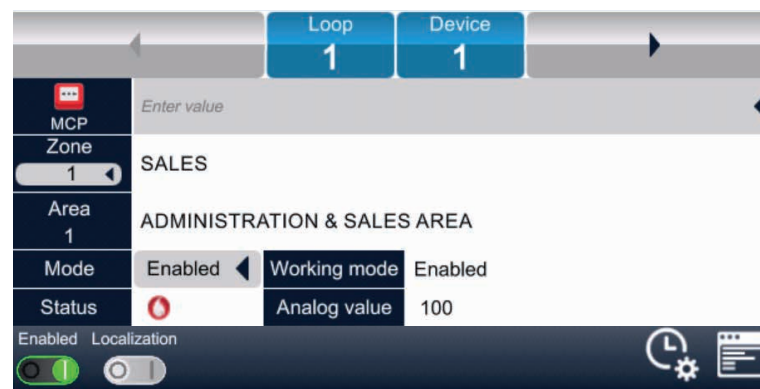

When selecting a device, the pop-up menu will allow you to view:



Item	Definition
	Call to the location of an entity on a map
	Call to the special modes associated with a zone or area device
	Call to the event log filtered by the entity selected

## 5.7. MANOEUVRES

A manoeuvre can be defined as a set of actions that are programmed on a control panel based on the statuses taken by the system, areas, zones or devices.

Status changes are called events, and an action will be linked to each event, such as the activation of sounders, relays, etc.

The process of programming a manoeuvre involves first defining the event or events that must trigger the action and then associating the action or actions.

 Manoeuvres may have an associated delay (in seconds, 0 to 600 seconds) so that an immediate action can be avoided in case of a false alarm. Consult the Advanced Configuration Guide for more details.

The following example creates a manoeuvre whereby in an event on a control panel, an action will be executed on the same panel or on another networked panel.

To programme a manoeuvre, carry out the following steps:

**LOOP** (Main menu) > **DEVICES** (Submenu) > **+ADD** (Navigation bar)



From the new manoeuvre management window, press:

**+ADD** (Lower navigation bar)

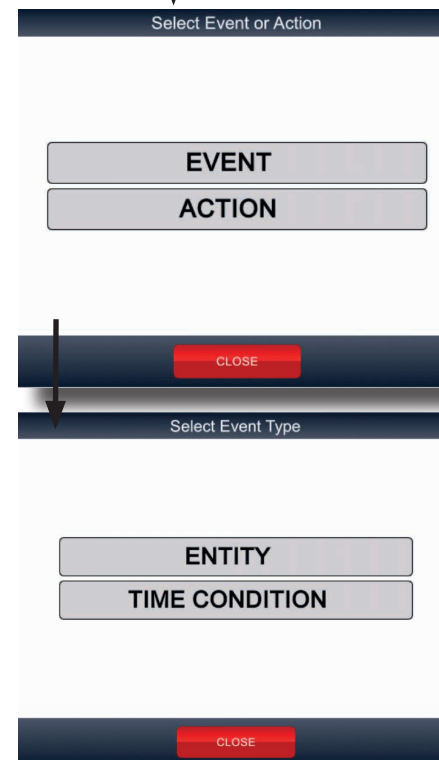

A floating window will let you select between **EVENT** and **ACTION**.

For this example, press **EVENT**.

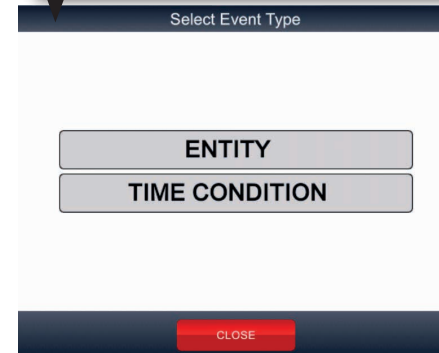

A new pop-up window will allow you to select between

**ENTITY** and **TIME CONDITION**

For this example, press **ENTITY**.



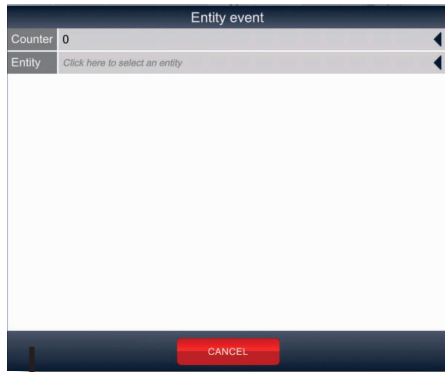

In the new **ENTITY EVENT** floating window you can configure the following fields

**COUNTER**

(number of times an event must occur in order to execute an ACTION). For this example, leave the counter at 1.

**ENTITY**

It is the Panel, Loop, Area, Zone, Element, Group or Virtual Module that due to a change in its status, will trigger an action

By pressing this option, a new floating window will allow you to choose between **LOCAL** or **NETWORK** entity.

For this example, select **LOCAL**.

It is now possible to select the action's trigger entity from the following options:

Panel, Loop, Area, Zone, Element, Group or Virtual Module.

For this example, press the **PANEL** tab

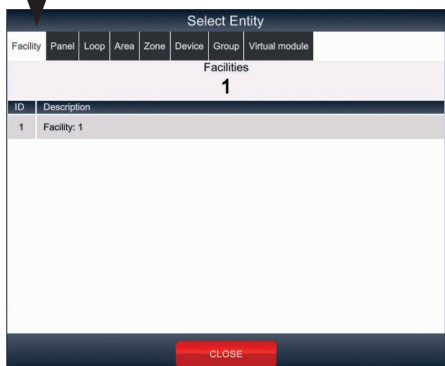
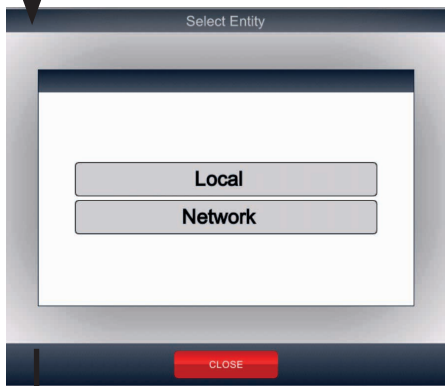

The Advanced Configuration Manual provides detailed information on each configuration parameter. The available fields depend on the type of entity selected.

Once the entity has been selected, the **ENTITY EVENT** window will be shown again and new available fields will appear.

**TYPE** It allows you to select the type of trigger event, such as fault or alarm but also what kind of device will shot the action.

**LOGIC** It allows you to select between normal and rejected, No

Press  , **SAVE** to update the database.

Press  , **CANCEL** to undo the proposed changes

The screen will return you to the LIST of events and actions for the

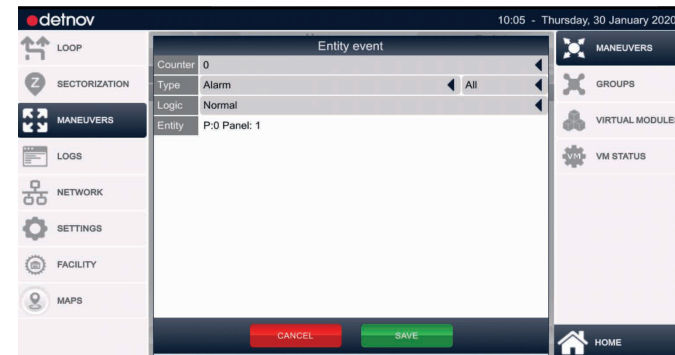

current manoeuvre. You see that there is an event defined, but there is no ACTION. To define one:

**+ADD** (Lower navigation bar).



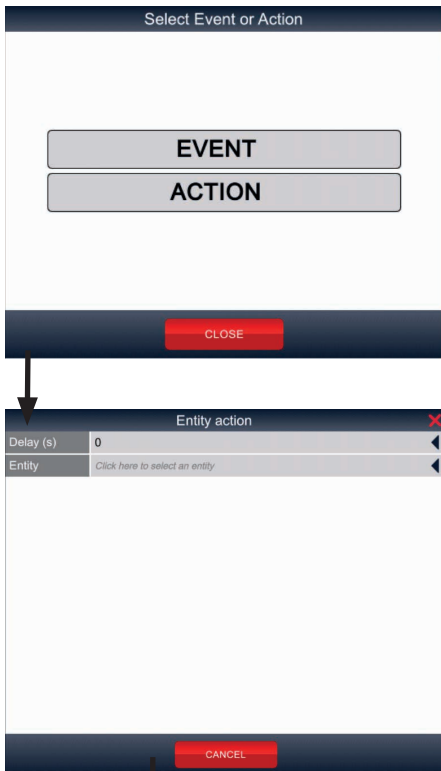

A floating window will let you select between **EVENT** and **ACTION**.

On this occasion, press **ACTION**.

A floating window, **ENTITY ACTION**, will be available with the following options:

**COUNTER**

(number of times an event must occur in order to execute an ACTION). For this example, leave the counter at 1.

**ENTITY**

Press the **ENTITY** field.



Once the entity is selected, the software will return you to the **ENTITY ACTION** window and will show new available fields.

The available fields depend on the type of entity selected.

Press **SAVE**, **SAVE** to Update the database.

Press **CANCEL**, **CANCEL** to undo the proposed changes

The control panel will return you to the manoeuvre list. Once the entity is selected, the software will return you to the **ENTITY ACTION** window and will show new available fields.

If you press the **MANOEUVRES** icon on the **MAIN MENU**, you can view the list of manoeuvres.

Now use the TABS to choose between the different types of entity.

For this example, press the **PANEL** tab.

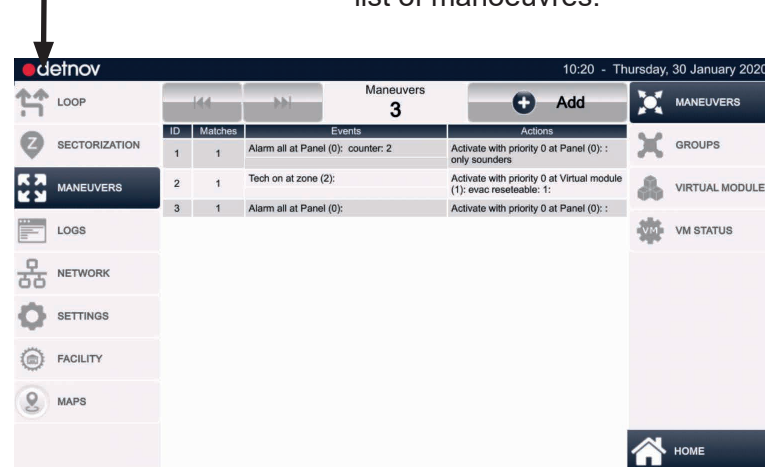
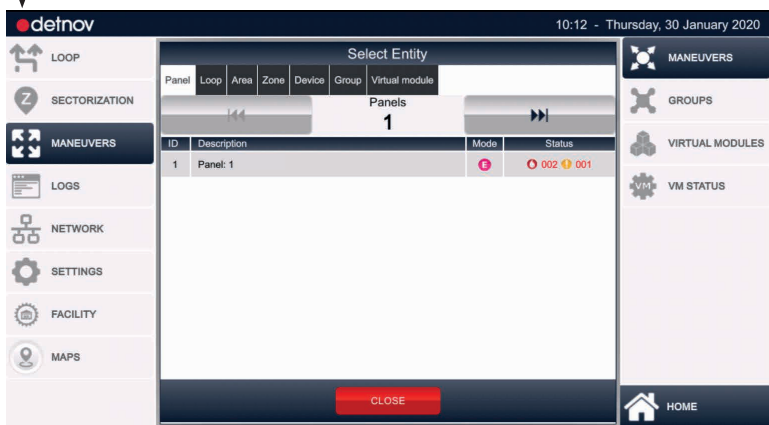

## 5.8. SOFTWARE UPDATE

One of the easiest ways to update the CAD-250 is via the USB TYPE A port using a PEN DRIVE.

Make sure that the PEN DRIVE is formatted as FAT32; it is not necessary for it to be empty.

Once the ZIP file that your supplier has sent to you is decompressed and copied to the PEN DRIVE root, carry out the steps below.

1. Locate the USB type A port on the MAIN BOARD and insert the PEN DRIVE.

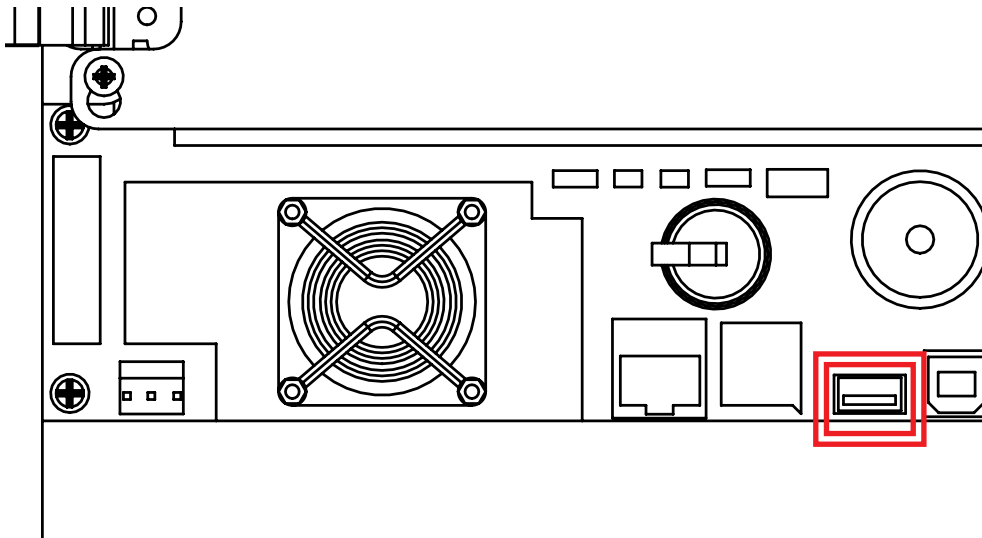

If you are not in the administrator screen, enter the password to exit the STANDBY screen.

A window will allow you to choose between two options:

**COPY TO USB:** Export the configuration and logs of a control panel.

**INSTALL FROM USB:** Import the different configurations available on a PEN DRIVE, both the databases of each configuration and the firmware or all.

2. To update the FIRMWARE press INSTALL FROM USB.

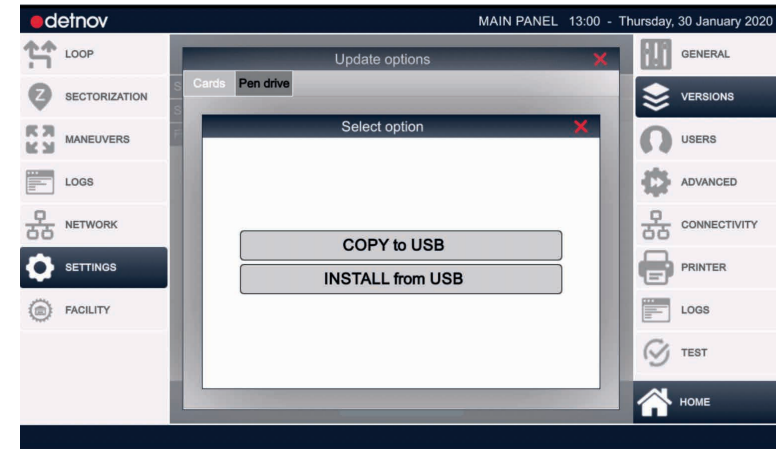

If the PEN DRIVE has configurations for different detection facilities, you will be able to choose between them:

3. Press the Facility 1 button.

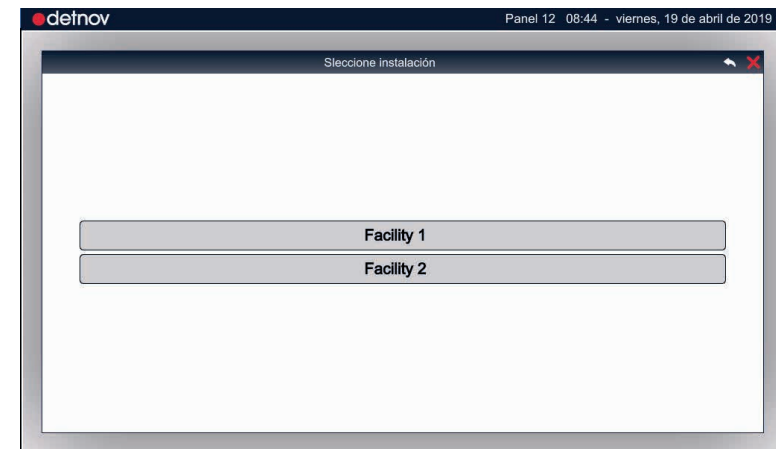

If the chosen facility contains various panels, you will be able to choose between the panels that comprise it.

4. Press the **Panel 1** button (1).

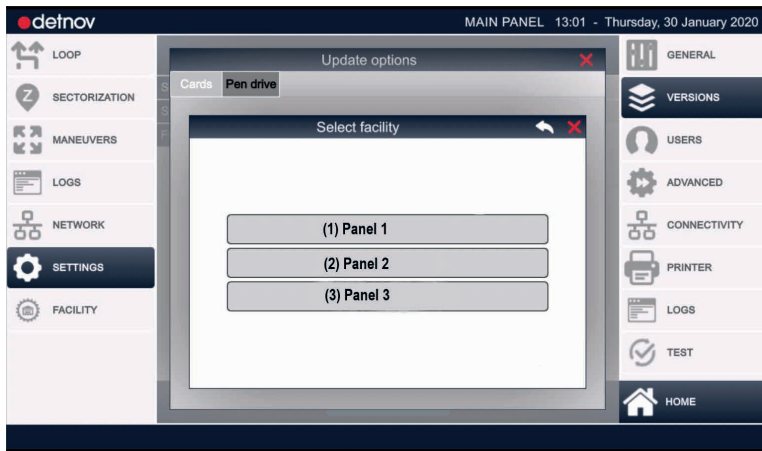

A window will ask you to confirm the FIRMWARE update.

6. Press the **FIRMWARE** button.

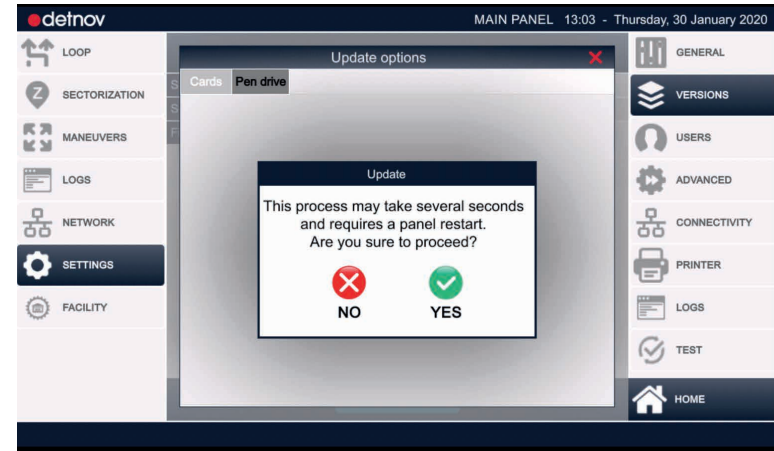

Once you have selected the panel, the system will indicate to you that you should choose between updating the Configuration database, the Firmware, or All.

5. Press the **FIRMWARE** button.

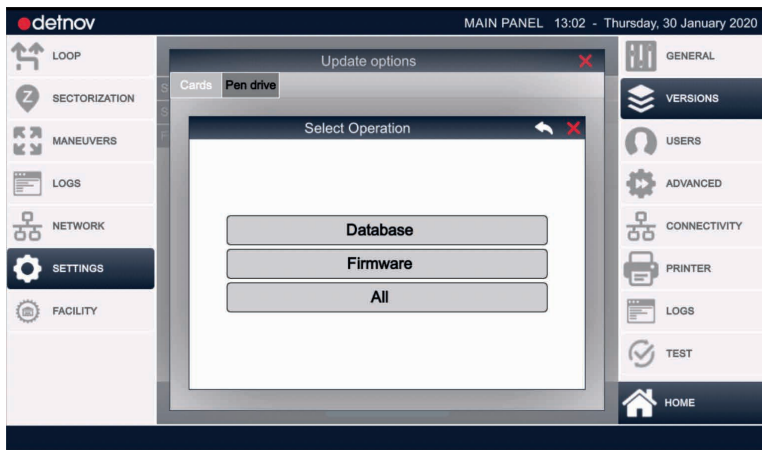

### 5.9. PANEL TEST

The test process allows you to check the operation of the LEDs of the MAIN PANEL and the screen. To access the TEST submenu, carry out the following steps:

**SETTINGS** (Main menu) > **TEST** (Submenu) > **START** (Button in the middle of the screen)

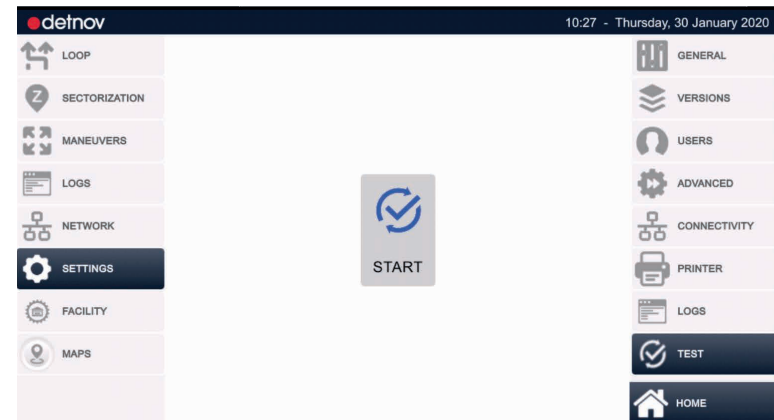

## 5.10. ETHERNET PORT CONFIGURATION

This submenu allows you to establish the basic parameters for network operation of the CAD-250 control panel. To access the CONNECTIVITY submenu, press:

**SETTINGS** (Main menu) > **CONNECTIVITY**(Submenu)

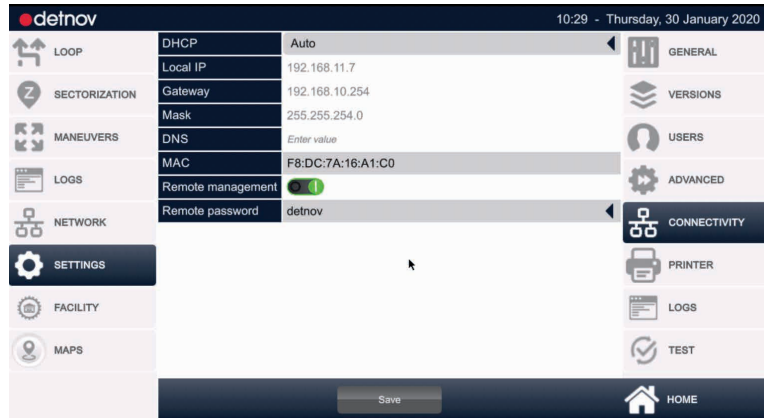

The screen will show a **CONFIGURATION TABLE** with the following fields:

Field	Definition
DHCP (MANUAL/AUTO):	Define whether the assignment of the control panel IP address is manual or automatic. Check with your network administrator for the type of IP assignment of your connection.
LOCAL IP (Editable):	If it is assigned manually, the IP address is assigned in this field. Check with your network administrator for the free IP address for this control panel.
GATEWAY (Editable):	If it is assigned manually, the IP address of the gateway is assigned in this field. Check with your network administrator for this address.
MASK (Editable):	If it is assigned manually, the IP address of the subnet mask is assigned in this field. Check with your network administrator for this address
DNS (Editable):	If it is assigned manually, the IP address of the domain name system is defined in this field. Check with your network administrator for this address
MAC:	This field shows the MAC (Media Access Control) physical address of the control panel network adapter.
REMOTE CONTROL (ON/OFF):	It allows remote access to the control panel through a VNC client.
REMOTE PASSWORD (Editable):	If the remote control is activated, this function allows you to set an access password for the control panel

## 5.11. NETWORK OPERATION

'Peer-to-peer' architecture. See section 314.

## 6. MAINTENANCE

### 6.1. LOG

According to the recommendations of the UNE 23007 Part 14 standard, you should create a log in which you can record the following information:

### 6.2. PERIODIC TESTS

To make sure that the system is completely operational, and to meet regulatory requirements, you should carry out the following recommendations periodically:

**DAILY:** Check the panel does not indicate any fault. Otherwise, record it in the log, as well as the measures taken, such as, for example, informing the maintenance company. Check the management of open actions.

**WEEKLY:** As a minimum, test a sensor or manual call points to confirm the panel and acoustic alarms are working. Test a different zone, and if possible also a unit, each week. Keep a log of the unit and zone tested each week. Record and report any anomaly.

**QUARTERLY:** Check:

- The log entries and the measures taken.
- The batteries in standby and the charger voltage.
- As a minimum, one unit from each zone to check the functions of the panel.
- The functioning of the acoustic alarms and any connection to a remote control centre, central station, etc.
- Perform a visual inspection of the facility to check for any alterations or obstructions and prepare a test certificate.

**ANNUALLY:** The person responsible must ensure that, as well as the quarterly checks, each unit of the system is tested and a visual inspection of the wiring and equipment is performed.

Methods that allow the physical detection principle to be verified must be used.

Check the execution of the programmed manoeuvres.

### 6.2.1. Test Mode

To carry out maintenance tasks, you must change the working mode of the zone or area where you are going to do the maintenance to **TEST MODE**; to do so, press:

**SECTORISATION (Main menu) > SELECTION TREE**

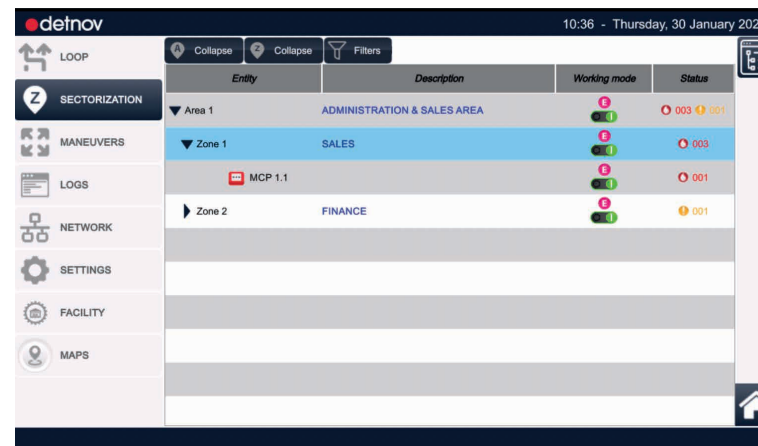

Check that the Working mode is shown with an "E" in the list

Press the zone that you wish to configure in test mode. A new screen will open with a **CONFIGURATION TABLE**.

Press on the **STATUS** drop-down menu and select **TEST**





Press on the **MODE** drop-down menu and select **TEST**

Note that in the device **TREE**, the **MODE** field of the device (1.1) has changed to **"T"**.

The screenshot shows the detnov control panel interface. The top bar displays the time '10:37' and the date 'Thursday, 30 January 2020'. The left sidebar contains navigation icons for LOOP, SECTORIZATION, MANEUVERS, LOGS, NETWORK, SETTINGS, FACILITY, and MAPS. The main area shows a tree view of the facility structure:

Entity	Description	Working mode	Status
Area 1	ADMINISTRATION & SALES AREA	E	003 001
Zone 1	SALES	T	003
MCP 1.1		T	001
Zone 2	FINANCE	T	001
Smoke 1.2	Description device 2 Smoke detector	T	001

While the test mode is enabled in an area or zone, the alarm signals sent by the devices contained in that area or zone will be saved in the event log of the control panel as events sent in **TEST** mode and no manoeuvre will be initiated. The input device will turn on the indicator light for a few seconds and after a while the device will reset.

To change an area to test mode, the procedure is similar. Access the **AREAS** submenu, in the **SECTORISATION** category, and select the one you wish to modify. Via the **CONFIGURATION TABLE**, change its mode.

**⚠ WARNING!** Remember that once you have completed the maintenance tasks of the detection network, you must return the zone or area to **ENABLED** mode.

## 6.3. CLEANING

The control panel must be cleaned regularly with a soft cloth dampened with water. Do not use solvents

## 7. TROUBLESHOOTING

This section aims to respond to the most common faults and problems you may come across when installing a CAD-250 control panel.

### 7.1. FAULTS SHOWN ON THE PRIMARY CONTROLS

The LEDs and primary controls of the CAD-250 control panel allow the user to know the status of the facility quickly and to initiate a series of actions easily. These LEDs normally indicate anomalies in the detection network or control panel.

**NOTE:** The European standard EN54-2 sets out the minimum requirements for this panel, including the buttons, visual and audible indications and its behaviour.

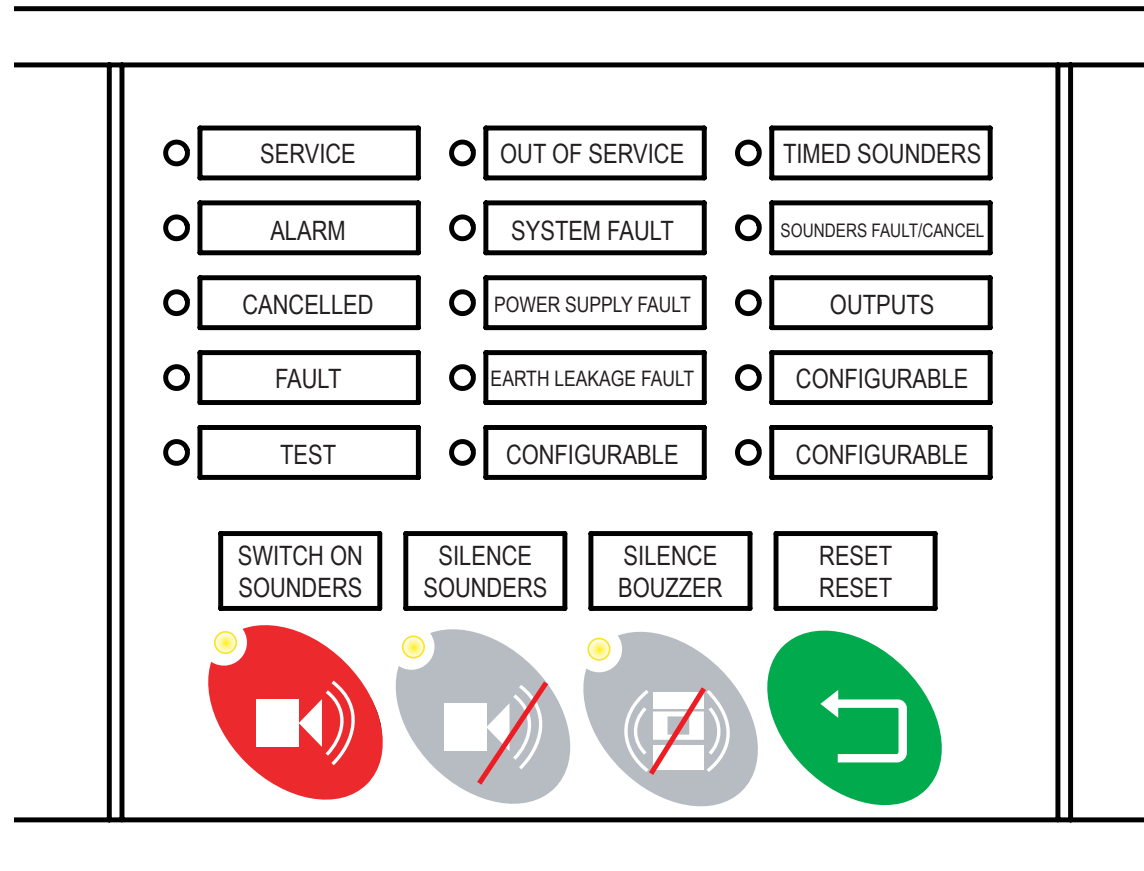









LEDS	CAUSE	SOLUTION
SERVICE (Green)	Switched on whenever the control panel is operating and powered.	If there is no power or it is out of service, the LED will switch off.
ALARM (Red)	Switched on whenever an event or alarm is detected.	Switched off if the control panel has no alarm event.
OUT OF SERVICE (Amber)	Switches on when the control panel has no power and the battery voltage is equal to or lower than 20 V.	Switched off when it is in service and there are no issues with the power supply.
CANCEL (Amber)	Switched on when a device is disabled, such as the buzzer or any disabled device.	When there is no disablement or cancellation of the buzzer.
TEST (Amber)	Switched on when a device/zone/area is in test mode.	Remains off if nothing is in test mode
FAULT (Amber - flashing)	Flashes when a fault occurs.	Stops flashing when there is no fault
SYSTEM FAULT	The microprocessor has stopped delivering pulses to the WatchDog, meaning that it is down.	If it is off, it means there is no problem regarding communication with the central processing unit or CPU.
POWER SUPPLY FAULT	It activates when a fault occurs in the batteries or the power supply.	Off when everything is working correctly in terms of the batteries and the power supply.
EARTH LEAKAGE FAULT	When the control panel detects an earth potential that is positive relative to GND.	Off when the condition that switches it on is not met.
TIMED SOUNDERS	It switches on when a delay or sounder is applied, whether from the PCB or a loop device.	If there is no delay associated with the sounders
SOUNDERS FAULT/CANCELLED	It switches on and flashes if there is a fault on any of the sounders. The FAULT LED also flashes. It switches on permanently, as does the CANCEL LED, when the disablement involves a sounder.	Off when neither of the previous two premises is met.
CANCELLED OUTPUTS	It switches on permanently when an output is disabled and is always accompanied by the CANCEL LED. For example, when an output module is disabled.	It is switched off when there is no output device disabled.

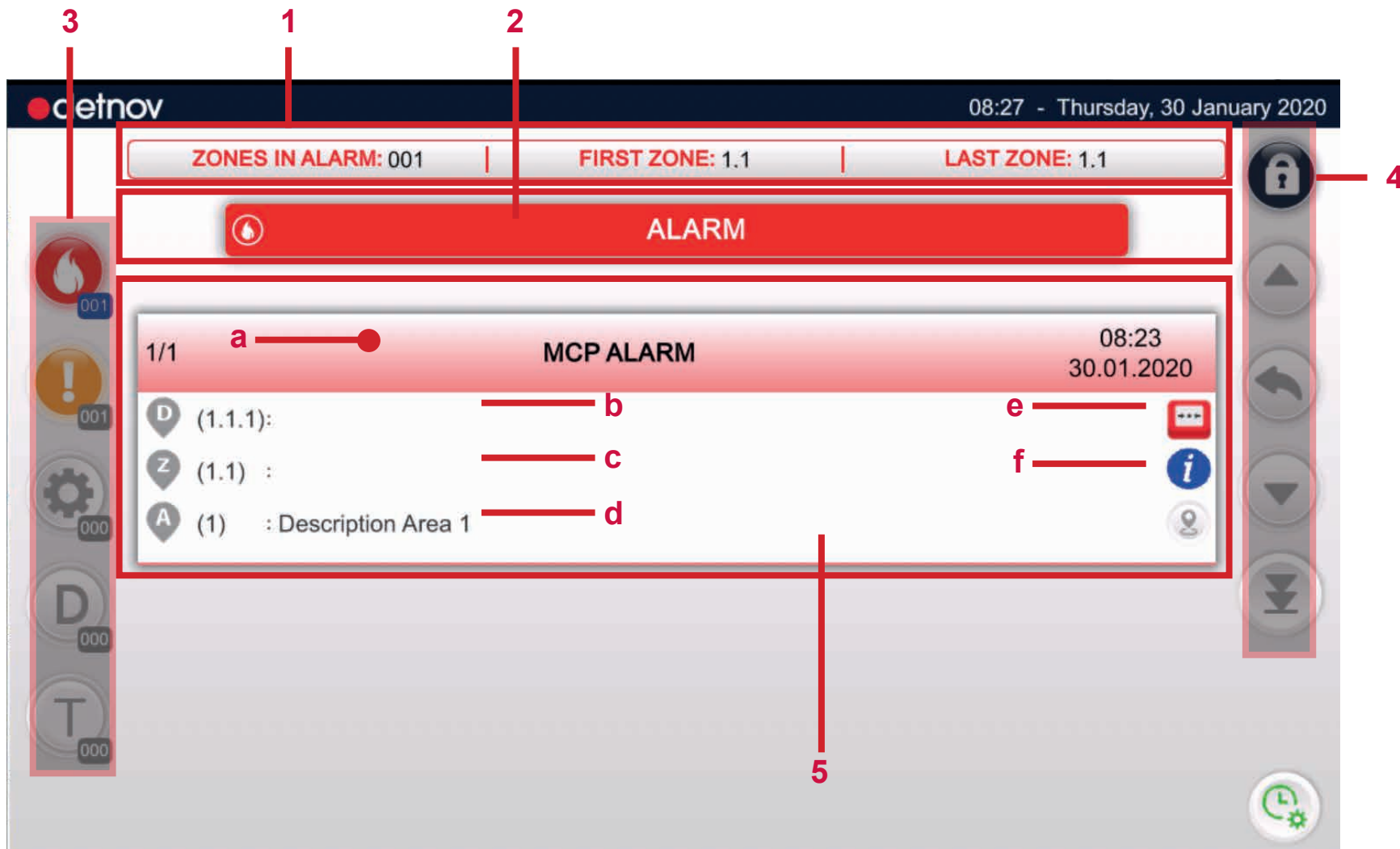





## 7.2. EVENT SCREEN

If an event occurs in the facility, the **STANDBY SCREEN** will change to the **EVENT SCREEN**. It is an environment that shows the events (alarms, faults, disablements, etc.) that are being detected in the facility. The screen is divided into various zones:

No.	Name	Description
1	ALARM BAR	It shows if there is an active alarm, according to the EN54-2 standard. It includes a zones in alarm counter; the first zone in alarm and the last zone in alarm.
2	STATUS BAR	The status bar only shows which event list you are in, the types of event it shows may be: ALARM, FAULT, TECHNICAL, DISABLED, TEST.



No.	Name	Description
3	STATUS COLUMN	List filters according to status. Each icon includes a counter that indicates the number of active events for each status.
		 The icon is highlighted when the counter shows 1 or more alarms. By touching the icon, the event list is filtered by that status
		 The icon is highlighted when the counter shows 1 or more faults. By touching the icon, the event list is filtered by that status
		 The icon appears highlighted when the counter indicates 1 or more active technical signals from input modules configured as technical input. By touching the icon, the event list is filtered by that status
		 The icon appears highlighted when the counter indicates 1 or more disabled entities. By touching the icon, the event list is filtered by that status
		 The icon appears highlighted when the counter indicates 1 or more entities in test status. By touching the icon, the event list is filtered by that status. The test mode is used to carry out maintenance tasks. The recorded events are not considered alarms and the devices will reset automatically a few seconds after being triggered.

No.	Name	Description
4	NAVIGATION	On the right side of the screen there is a column of navigation icons
		 It allows access to higher user and configuration levels
		 Scroll up the list; by touching it, the previous incident will be shown successively.
		 An item is highlighted only if technical events are detected, pressing it returns you to the standby screen
		 Scroll down the list; by touching it, the following incident will be shown successively.
		 If you are in the last event, it will return you to the first one and it will take you to the last one if you are in the first
		 It shows the supplier's contact information if a fault has occurred and if it was defined from the configuration menu.
 It is highlighted if special modes are activated. When you touch the icon, a list of modes that have been configured is shown.		

5	EVENT WINDOW	<b>a</b> EVENT BAR: it describes the type of event, as well as the date and time it occurred.
		<b>b</b> DEVICE IDENTIFICATION: a number that codifies the device's position in the loop appears next to the icon ('control panel identification', 'loop identification', 'device address') and the description of the device.
		<b>c</b> ZONE IDENTIFICATION: It shows the panel number and the zone that codifies the device's position in the loop, as well as the current description of the zone
		<b>d</b> AREA IDENTIFICATION: It shows the area number and description associated with the event identified.
		<b>e</b> DEVICE TYPE: it graphically identifies the device type.
		<b>f</b> EVENT INFORMATION: Icon highlighted and active when there is additional information regarding the event. By touching the icon, the CONFIGURATION TABLE opens with information regarding the event, which allows certain parameters to be changed.

Under the FAULTS icon in the EVENT SCREEN, the different system faults are shown. Below is a list of errors, causes and solutions for each of them:

DEVICES	CAUSE	SOLUTION
OPEN FAULT	This fault is due to the lack of end-of-line monitoring of some devices with this feature. For example, the input modules where monitoring mode can be configured with a switch. Where via an end-of-line resistor, "open fault" is indicated if it is not present.	Replace the end-of-line monitoring or change the switch and do not carry out the monitoring.
24 V FAULT	A loop device needs 24 V power, such as certain input/output modules or a zone module, and this is not being carried out correctly.	To resolve it, repower the device correctly.
SHORT-CIRCUIT FAULT	There is a short circuit in an input device or zone module.	Check the affected device and undo the short circuit.
DOUBLE ADDRESS FAULT	There are two devices with the same address in one loop.	Change the device address to another that is free.
DEVICE REMOVED	A device has been removed from the loop	Carry out an auto search or change the device type again from the configuration software to the correct type.
TYPE FAULT	An incorrect type has been assigned to one of the facility's devices with the configuration software. For example, there is a detector installed on address 1 of loop 1, but with the software, a manual call point was assigned to that address.	Carry out an auto search or change the device type again from the configuration software to the correct type.
DIRTY FAULT	Dirty fault due to a dirty detector. This fault is activated because the option: <b>FACILITY &gt; LOOP &gt; DIRTYNESS NOTIFICATION</b> is activated.	Change the control panel's configuration so that it does not detect this fault or it cleans the detector.
UNCONF FAULT	A device has been introduced in a loop without previous configuration, although it is correctly addressed and the option: <b>FACILITY &gt; LOOP &gt; NOT CONFIGURED NOTIFICATION</b> is activated.	Remove the device or carry out a new auto search of the affected loop.

LOOPS	CAUSE	SOLUTION
OPEN SOUNDER FAULT 1 OR 2	The end of line (4K7 resistor) of the sounders is not detected.	Fit the end-of-line resistor to ensure proper monitoring.
SHORT-CIRCUIT IN SOUNDER FAULT	There is a short circuit on sounder outputs 1 or 2 of the PCB.	Locate the short circuit
24 V OUTPUT FAULT	The 24 Aux 0.5 A fuse on the PCB is blown.	Change the fuse.
BATTERY FAULT	The control panel detects that there is no battery and the option: <b>FACILITY &gt; LOOP &gt; BATTERY FAULT</b> is activated.	Change the battery
BATTERY CHARGER FAULT	It is generated when the control panel detects that the drop on the battery terminals is more than 3 ohms.	Look for the earth leakage point.

LOOPS	CAUSE	SOLUTION
EARTH FAULT	The control panel detects that there is an earth leakage and the option <b>FACILITY &gt; LOOP &gt; EARTH FAULT</b> and <b>JUMPER JP7</b> are activated.	Check and correctly connect the power supply.
MAIN POWER FAULT	Power supply fault	Check the power input fuse, the position of the electrical protection element lever and/or the mains power supply.
HIGH TEMPERATURE	The charger temperature is above the maximum	Check the battery connections.
OUT OF SERVICE	When the control panel is without power and the battery charge is below 20 V and is close to switching off.	Reconnect the power supply.
ISO OPEN FAULT (S) OR (R)	The loop is open. The fault indicates whether the fault is on the output (O) or return (R) of the loop, or on both.	Locate and repair the fault in the loop.
ISO SHORT FAULT (S) OR (R)	There is a short circuit in the loop. The fault indicates whether the short circuit is on the output (O) or return (R) of the loop.	To resolve it, repower the device correctly.

## 8. TECHNICAL SPECIFICATIONS

This fire control panel was designed, manufactured and certified in accordance with the subsections of the following European standards:

EN 54-2:1997,

EN 54-2:1997/AC:1999,

EN 54-2:1996/A1:2006

EN-54-2	SUBSECTION	
General requirements	4.	PASS
General requirements for the indications	5.	PASS
Standby state	6.	PASS
Fire alarm state	7.	PASS
Fault warning state (annex F)	8.	PASS
Disconnected state	9.	PASS
Test state (option with requirements)	10.	PASS
Design requirements	12.	PASS
Additional design requirements for control and indication units controlled by the software	13.	PASS
Marking	14.	PASS
Cold (operational)	15.4	PASS
Damp heat, steady state (operational)	15.5	PASS
Impact (operational)	15.6	PASS
Vibration, sinusoidal (operational)	15.7	PASS
EMC immunity	15.6	PASS
Variation of the supply voltage	15.13	PASS
Damp heat, steady state (endurance)	15.14	PASS
Vibration, sinusoidal (endurance)	15.15	PASS

The CAD-250 control panel was designed, manufactured and certified in accordance with the subsections of the following European standards:

EN 54-4:1997,

EN 54-4:1997/AC:1999,

EN 54-4:1997/A1:2002,

EN 54-4:1997/A2:2006

EN-54-4	SUBSECTION	
General requirements	4.	PASS
Functions	5.	PASS
Materials, design and manufacturing	6.	PASS
Documentation	7.	PASS
Marking	8.	PASS
Cold (operational)	9.5	PASS
Damp heat, steady state (operational)	9.6	PASS
Impact	9.7	PASS
Vibration, sinusoidal (operational)	9.8	PASS
Electrostatic discharges (operational)	9.9	PASS
Damp heat, steady state (endurance)	9.14	PASS
Vibration, sinusoidal (endurance)	9.15	PASS

## MECHANICAL SPECIFICATIONS

**MATERIALS:** Iron sheet housing with a thickness of 1.2 mm. ABS front with V0 fire resistance

**DIMENSIONS:** Maximum measurements of the control panel (in mm):

Width: 533 / Height: 450 / Depth: 225

**WEIGHT:** Without batteries: 12.5 kg  
With NP24-12 batteries: 30.5 kg

## ENVIRONMENTAL SPECIFICATIONS

**CLIMATE CLASSIFICATION:** 3K5, (IEC 721-2-3)

**OPERATING TEMPERATURE:** from -5°C to +40°C

**HUMIDITY:** from 5% to 95% RH

**PANEL PROTECTION:** IP 30, (EN 60529)

**EMC** Immunity EN 50130-4  
(electromagnetic compat.):

## INDICATION SCREEN

**0" TOUCHSCREEN:** IPS, 1024x600 pixel resolution, 300 dpi touch resolution

**PRIMARY INDICATORS:** Service, Alarm, Disabled, Fault, Test, Out of service, Power supply fault, System fault, Earth leakage, Sounder delay, Sounder fault/disablement, Disabled relays.

**ZONE INDICATORS** 250 alarm indications and 250 fault indications  
(Optional):

## CONTROL KEYS

Switch On Sounders, Silence Sounders, Silence Buzzer, Reset.

**EXTERNAL CONNECTIONS:** 2 USB ports, 1 Ethernet port  
1 RS232 port for printer

**CABLE ENTRIES:** 10 entries with a diameter of more than 23 mm  
421 x 55 mm on the back

**EXPANSION INPUTS:** 2 (upper and lower)  
measuring 50 mm x 15 mm

**CONDUIT ENTRIES:** 2 side entries (left and right)  
measuring 100 mm x 35 mm

**EXTERNAL POWER INPUTS:** Rear input measuring 50 x 74 mm  
Lower input measuring 35 x 75 mm

## ELECTRICAL SPECIFICATIONS

**CLASSIFICATION:** Class I facility (the panel must be earthed)

**POWER SUPPLY:** 88 V-264 V~(ac),  
3 A (115 V), 2 A (230 V)

**FUSE:** 4 A

**INTERNAL BATTERIES:** 24 Ah-12 V

**OUTPUTS:** 2 Sounder outputs / 2 Fault outputs  
/ 1 Auxiliary output of 24 V / 8 Loop outputs (optional)

## SOUNDER OUTPUT VALUES

**TYPE:** Inverted voltage.

**OUTPUT VOLTAGE:** active 26 to 28 V /  
inactive -6 V to -7 V

**MAXIMUM LOAD:** 0.45 A

**FUSE:** 0.5 A

**MONITORING:** Open circuit and short circuit

## RELAY OUTPUT VALUES

**TYPE:** Single pole changeover switch

**MAXIMUM LOAD:** 28V 10A contacts

## 24 Vdc AUXILIARY OUTPUT VALUES

**OUTPUT VOLTAGE:** From 26 Vdc to 28 Vdc

## LOOP OUTPUTS

**OUTPUT VOLTAGE:** 26 Vdc to 33 Vdc (Detnov protocol)

**MAXIMUM LOAD:** 0.45 A

**MAXIMUM DEVICES/LOOP:** Up to 250 devices (\*)



(\*) The number of elements may be limited by local requirements, system autonomy and the requirements of the emergency plan.

Take into account the consumption of the devices at the most unfavourable time, for e.g. alarm or evacuation in relation to the maximum current of the loop and the necessary autonomy.



The specifications and features described in this manual may be subject to modification without prior notice by the manufacturer.

## ANNEX 1: TOTEM INSTALLATION

One of the main features of the CAD-250 control panel is its expansion capacity, thanks to the possibility of modular assembly, which offers the user a completely flexible system.

It is possible to create an assembled set in the form of a tower of 2, 3 or 4 control panels. In the case of network assembly, the set constitutes a single node and provides the CAD-250 system with enormous flexibility and capacity, covering the needs of any fire detection facility.

In this way, the nested control panels behave as a single control panel and can manage up to:

- 32 loops
- 8000 devices

The tower assembly must be composed of:

Unit	Reference	Description
Min. 1 unit	CAB-250	Main cabinet with interface Expands up to + 8 loops The ref. does not include the loops
Max. 1 unit	CAB-250-BLED	Cabinet with 250 dual LEDs for zones Expands up to + 8 loops The ref. does not include the loops
Up to 2 units	CAB-250B	Blind cabinet to expand up to + 8 loops The ref. does not include the loops



Before fixing the control panels to the wall, plan the installation. Take into account:

Where you are going to wire the main power lines, loop lines, sounders, relays, etc. to and via the control panel.

Map out each control panel preferably from the back of each unit or cabinet.

Make sure there is enough height, especially in the case of stacking 4 control panels, as the total height will reach almost 2 metres. Locate the main cabinet at eye level, approx. 1.5 m.

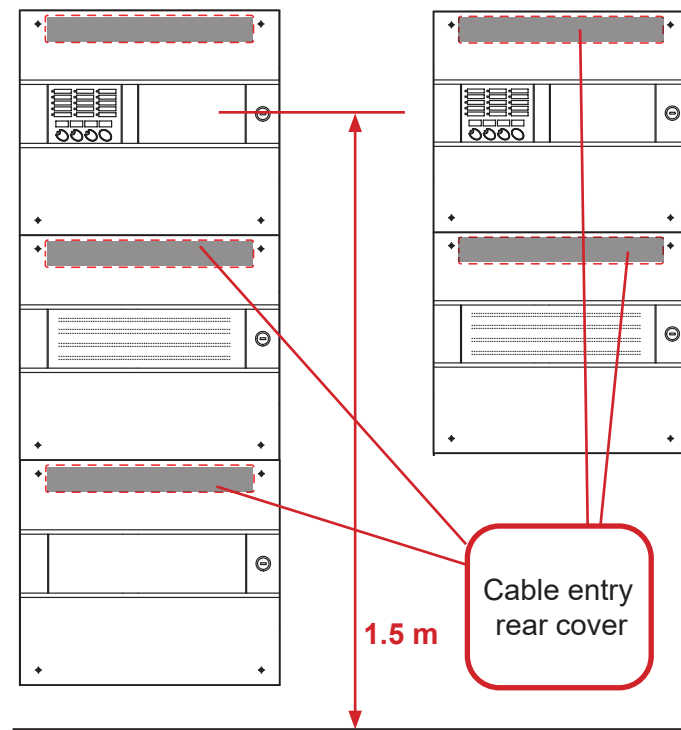

For the correct installation of a control panel tower or totem, you will need the SPR\_250 wall supports, which will allow an orderly and easy assembly.

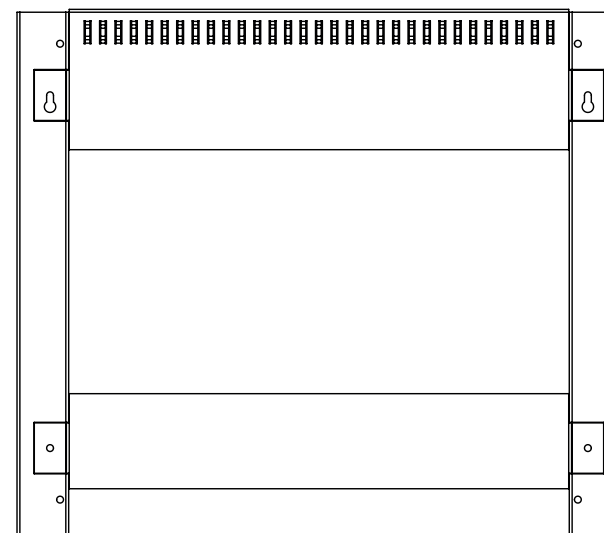



The support consists of two work planes:

- The front plane, through which the cables that will enter the control panel located at this level will run.
- The rear plane, through which the cables that will be connected to the control panels of the lower levels will be guided.

Due to the variety of cable diameters that are used for the loops in the facilities, this support allows a tower or totem composed of 3 control panels to be wired. These supports are fixed to the wall with the same wall plugs and screws with which the control will be fixed to the wall.

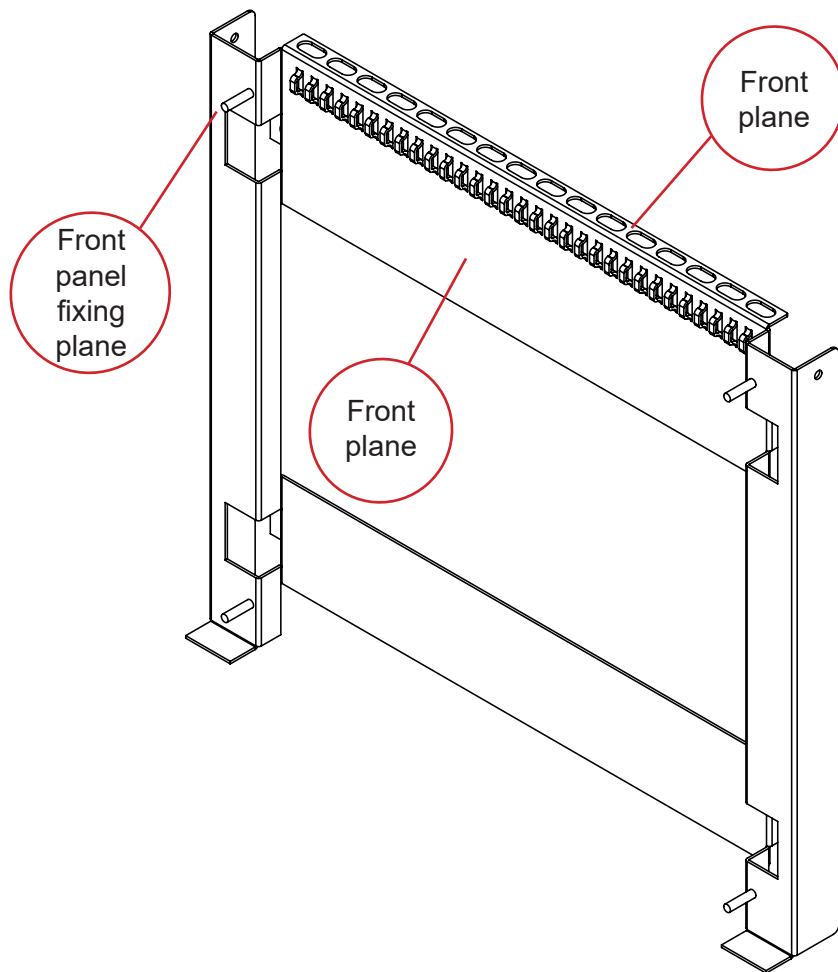

Firstly, fit the support to the lower control panel, taking into account that the screen of the **MASTER** control panel (the control panel that has the touchscreen) must be at a height of approximately 1.5 m from the floor

Each support has 4 fixing holes:

- The upper two are oval-shaped for easy installation; fit these screws first and hang the support from the wall.
- The lower two are used to lock the support in place, preventing it from moving upwards and the screws of the upper holes from coming out of the oval holes. Fit these screws last.

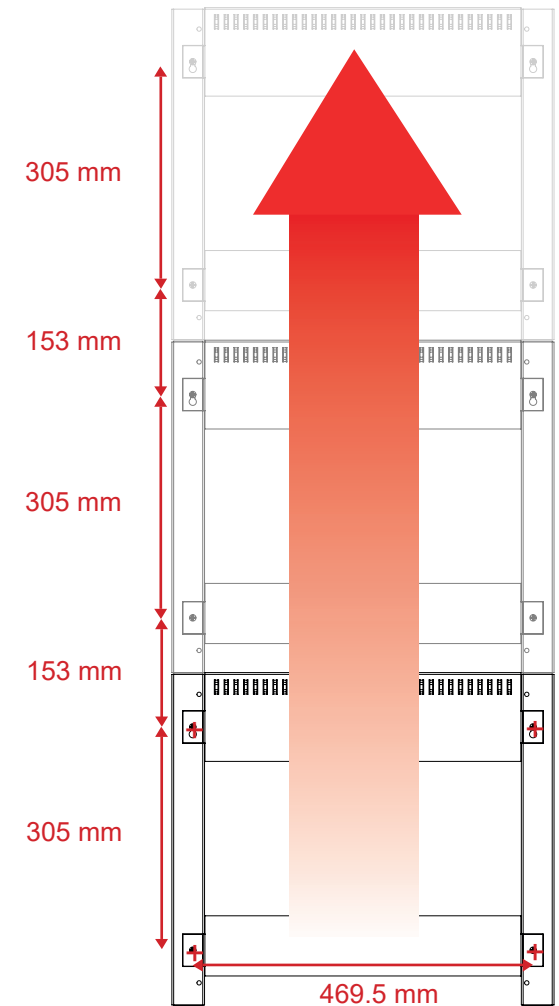

Once the lower support is installed, fit the one that goes directly above it following the same procedure and let the latter rest lightly on the lower one.

On the **FRONT PLANE** of each support, starting from the left, fit the necessary ties for the zone line cables that will enter the control panel at each level. Proceed in the same way with the remaining supports.

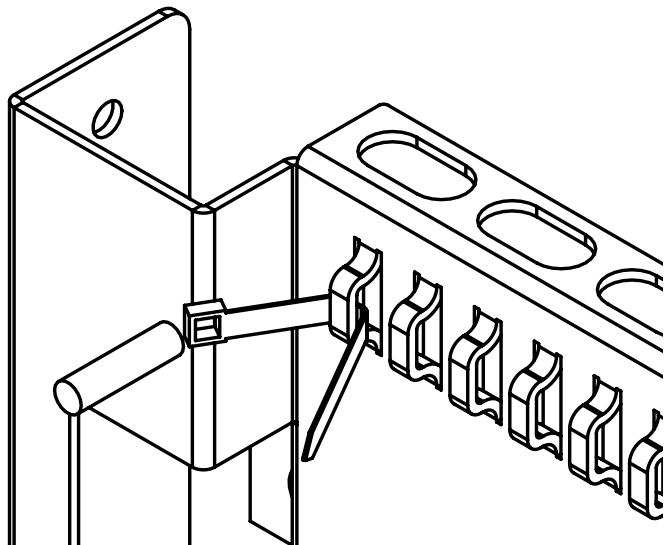

On the **REAR PLANE** of each support, fit the cable lines that will continue to the lower control panels, starting with the cable lines that go to the control panel lowest down. Each hole allows the **OUTPUT** line and the **RETURN** line of a loop to pass through it.

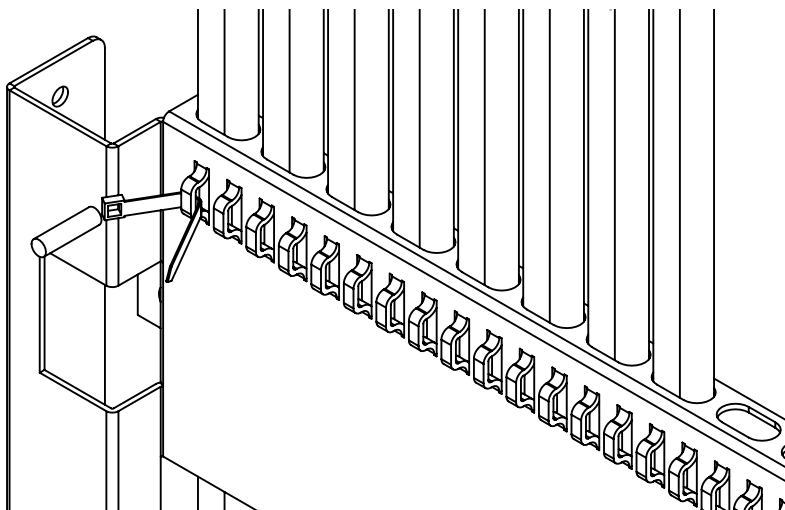

Once the cables that go to the lower control panels are fitted, fit the cable lines that will enter the control panel installed at the current level, using the ties that you installed previously.

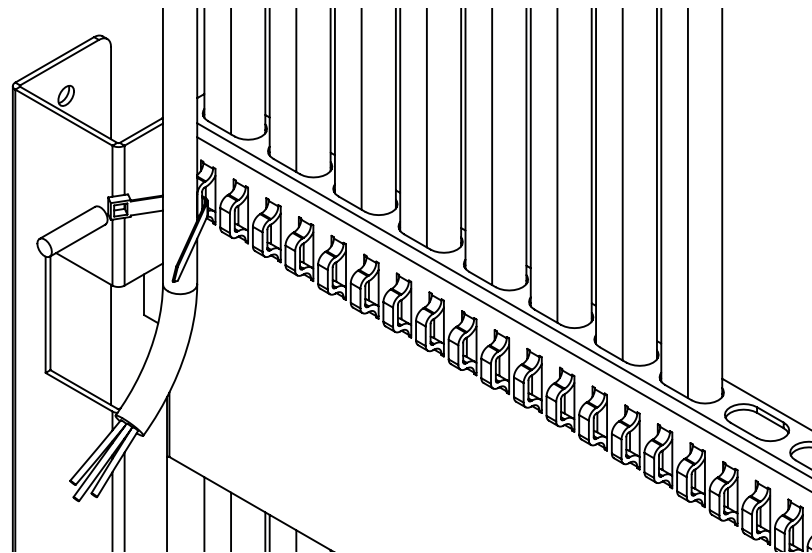

In this example, you can see that 8 cables will enter the control panel of the current level (**OUTWARD** and **RETURN** of 4 **LOOPS**), whereas 8 zones (16 cables) run through the **REAR PLANE** of the support, which will run down to the lower levels.

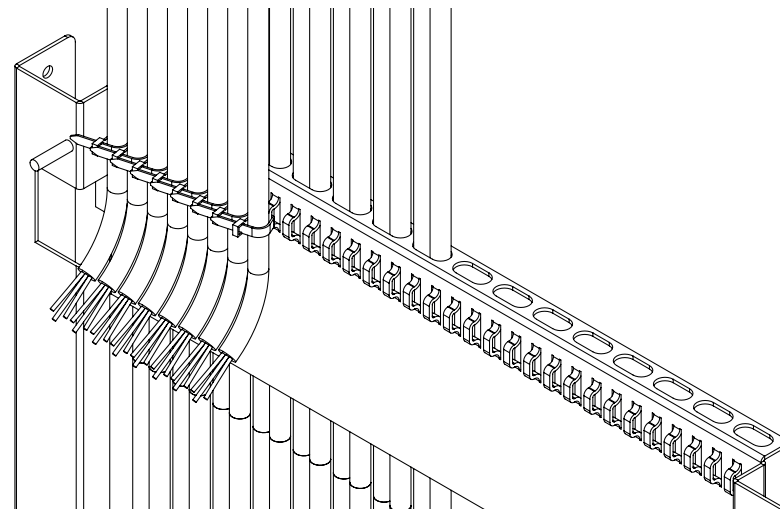

Continuing with the previous example, in the event of installing a tower or totem of 3 control panels with 4 zones per control panel, the wiring layout will be as follows

#### FRONT PLANE:

- On the upper level, LOOPS 1, 2, 3, 4 go down the front part to enter the control panel located on this level.
- On the intermediate level, LOOP lines 5, 6, 7 and 8 pass from the rear plane to the front one and are fixed with the corresponding ties.
- On the lower level, LOOPS 9, 10, 11 and 12 pass to the front plane to be connected to the last control panel.

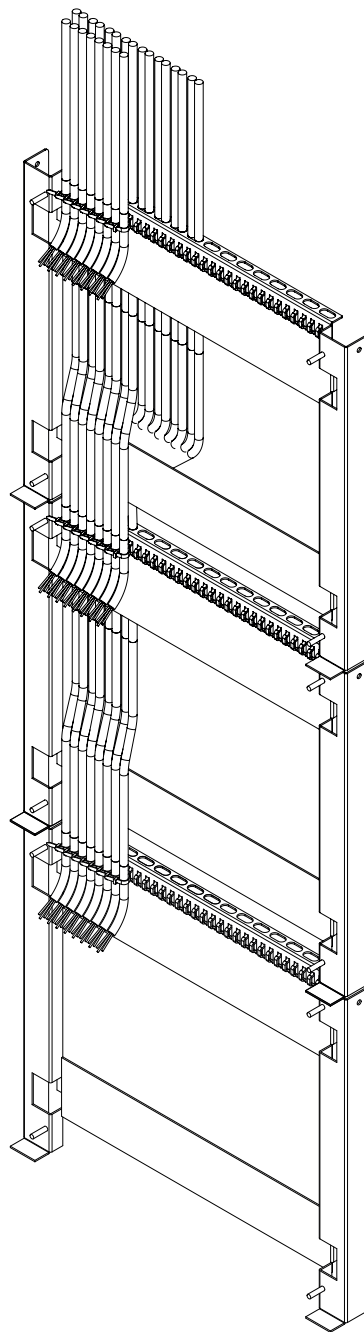

#### REAR PLANE:

- On the upper level, LOOP lines 5, 6, 7, 8, 9, 10, 11 and 12 run through the back of the support.
- On the intermediate level, LOOP lines 9, 10, 11 and 12 pass through or occupy the oval holes that loop lines 5, 6, 7 and 8 have left free on the left part of the intermediate support.
- On the lower support, LOOP lines 5, 6, 7 and 8 pass to the front plane and are fixed with the corresponding ties.

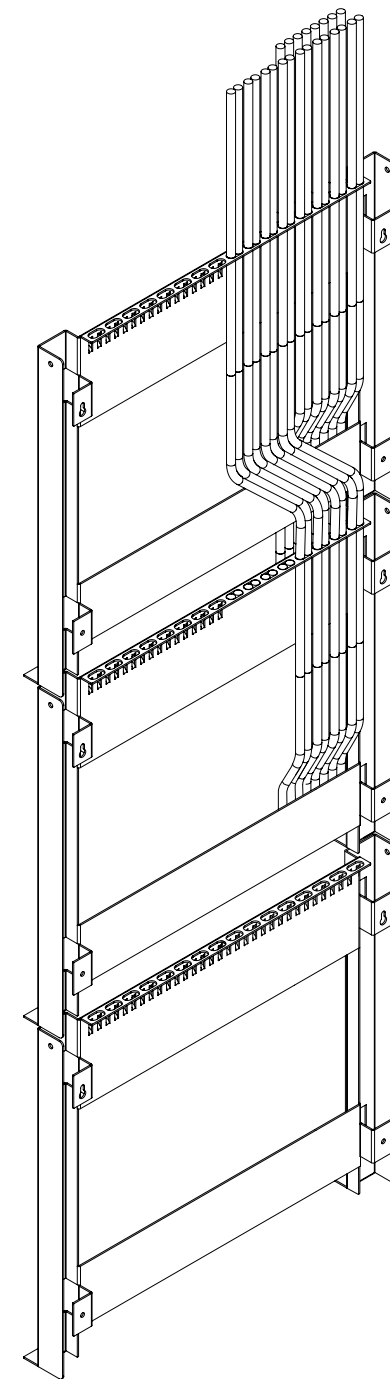

Once the supports are installed, continue with the installation of the control panels. To do so:

### 1. Locate the expansion covers.

**EXPANSION COVERS:** located on the left part of the control panel, one on the upper face and one on the lower. You will pass the link cables between the different sections or cabinets through these holes. Each expansion cabinet (CAD-250-B and CAD-250-BLED) is supplied with two connection cables.

**FIXING COVERS:** If you decide to install a control panel tower without using the support, fix some control panels to others via the holes on the upper and lower face of the control panel. Use M8 nuts and bolts.

2. Once you have decided the position of each control panel of the tower, only remove the expansion cover and the lower fixing cover from the cabinet that is in the highest position.

3. Only remove the upper expansion covers from the cabinet that you are going to install under the main cabinet, if you are not going to include an additional cabinet under it. If you are planning to include an additional cabinet, also remove the expansion and lower fixing covers.

4. Remove the rear pre-cut cover for each cabinet where cables will be entered.

To remove the covers, bend them repeatedly using a screwdriver until they come loose.

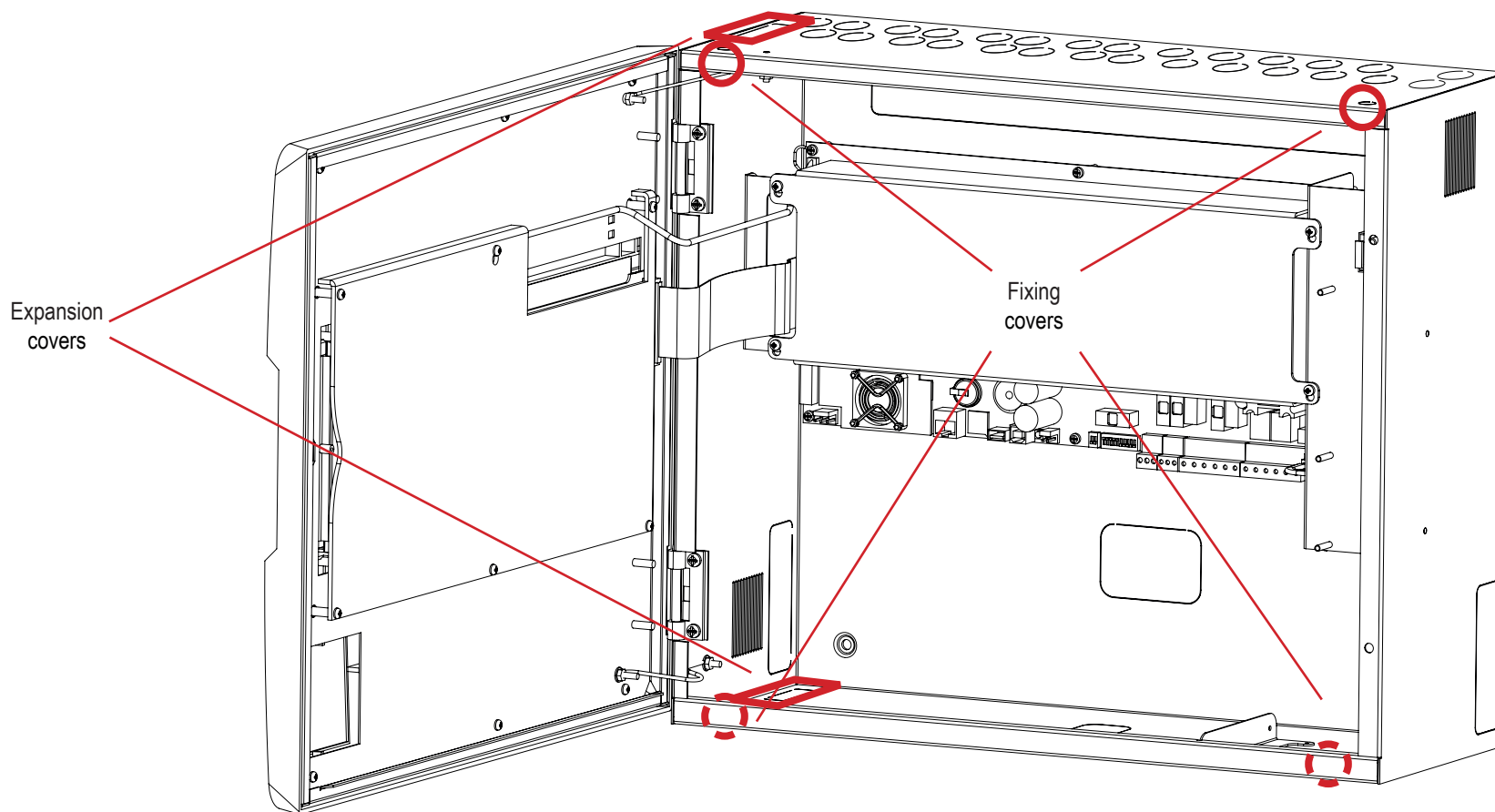

5. Now fit the lower control panel first, support it on the lower brackets of the support and fix it to the bolts of the support using the M6 nuts supplied with each support.

6. If you configure a totem without the SPR250 support, fix the control panels to each other using M8 nuts and bolts.

7. Pass the cables that correspond to the lower cabinet through the hole of the rear cover.

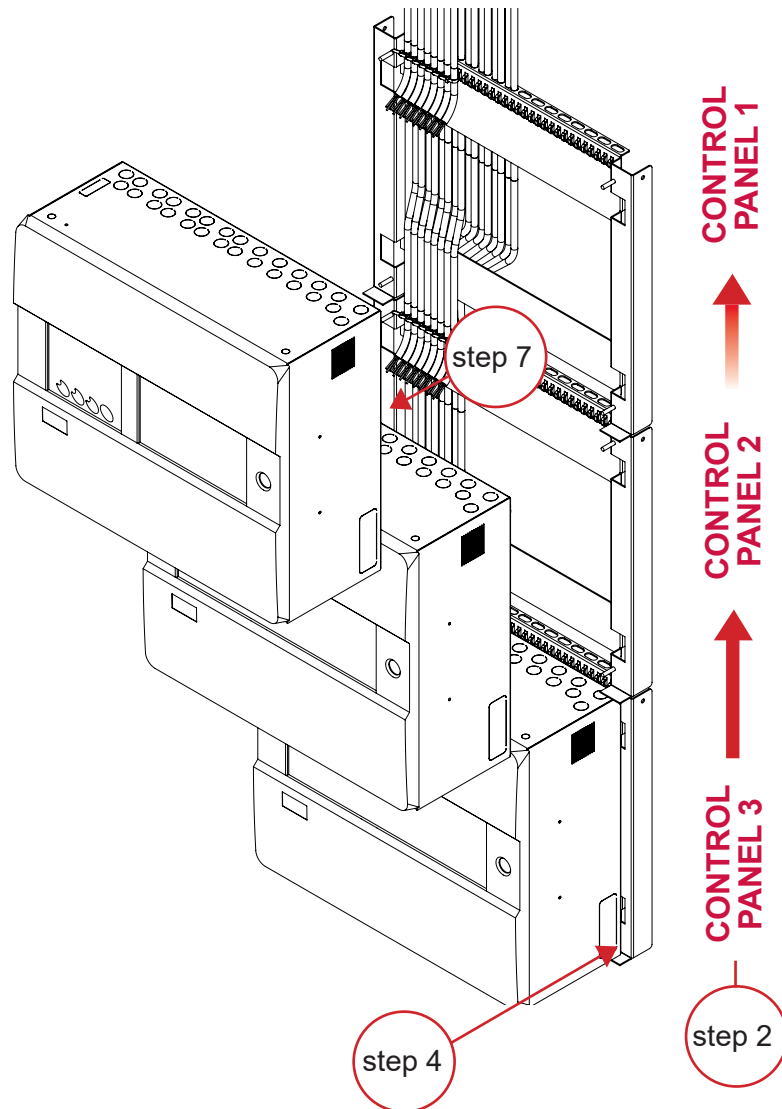

Repeat the process with the control panel that goes immediately above it. As such, the control panels will be perfectly aligned with each other and the complete connection of the system will be easy. Install the rest of the control panels in the same way, successively.

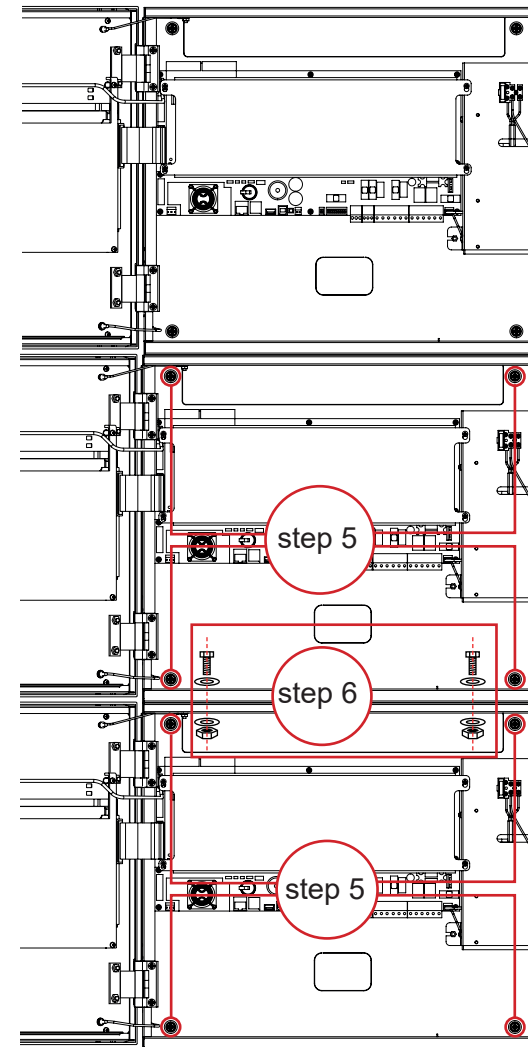

7. Install each loop card that corresponds to each cabinet as indicated in sections 3.7 and 3.8.

Install the cards in the order indicated, successively, from left to right and from the top control panel to the next one. It is not necessary to occupy all loop card locations of each cabinet; **it is only essential to respect the order and not leave empty locations between them.**

8. Interconnect the main cards with the cables supplied with each expansion cabinet.

The expansion cables must pass from one cabinet to another through the expansion holes opened in step 1.

9. Locate the expansion SW2 configuration microswitches (see section 3.4).

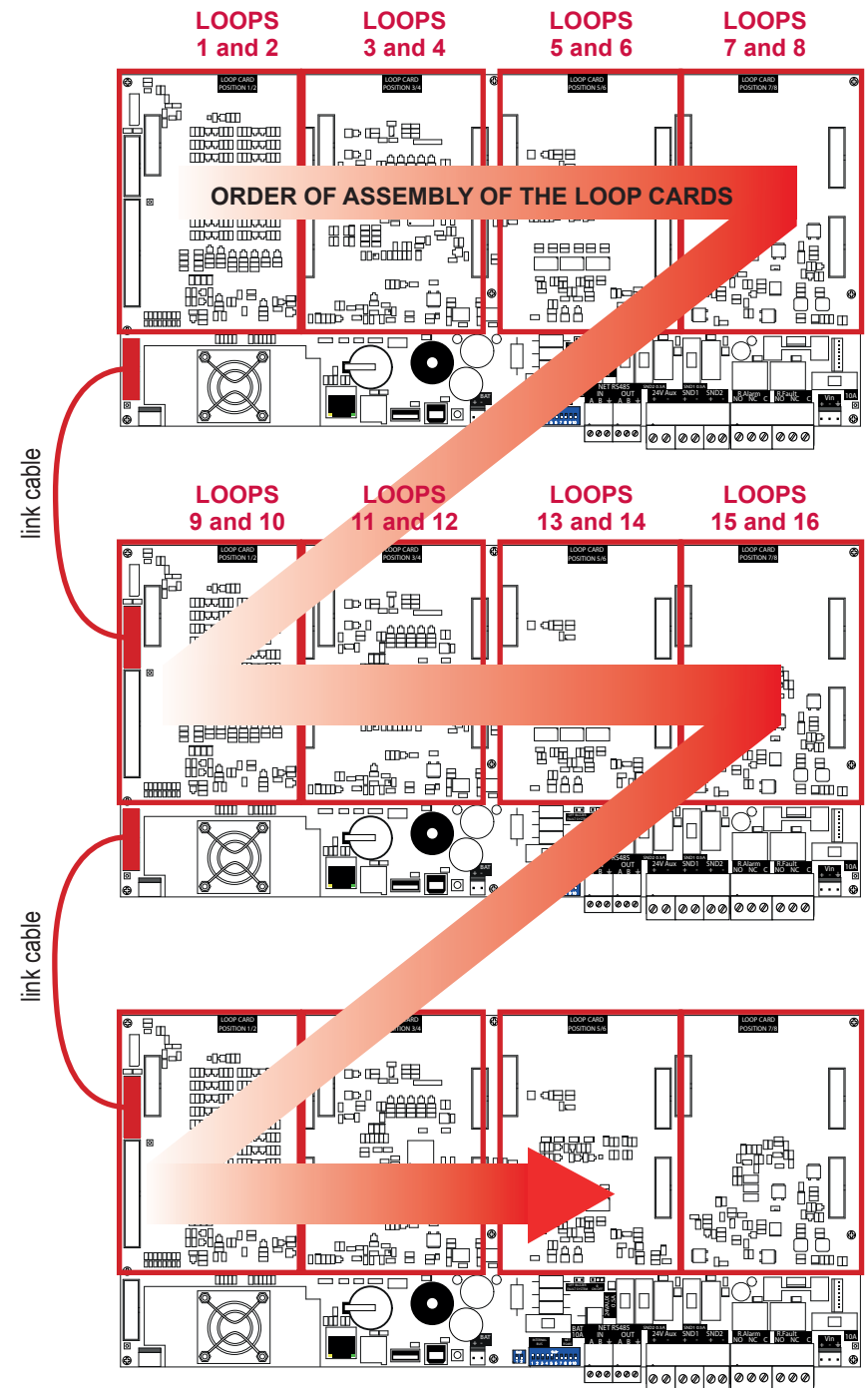
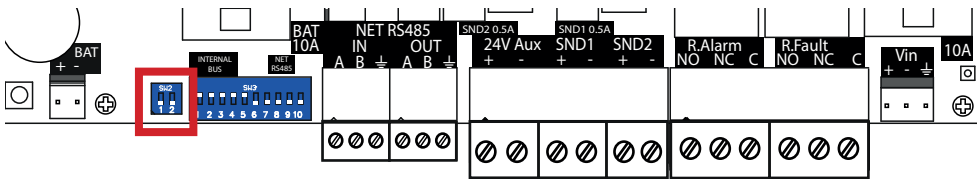

10. Configure the **CONTROL PANEL IDENTIFICATION** for each control panel that forms the TOTEM by configuring SW2 correlatively from top to bottom.

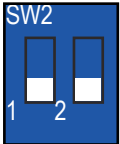
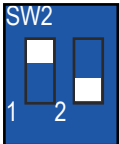
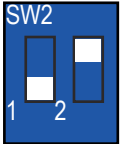
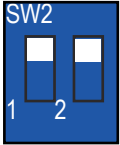
Position		
	Cabinet 1	The cabinet in the highest position. The control panel will recognise the loops of this control panel as the first of the control panel, starting from left to right.  Default configuration of the CAB-250 control panel
	Cabinet 2	Configuration for the cabinet on the second level.
	Cabinet 3	Configuration for the cabinet on the third level.
	Cabinet 4	Configuration for the cabinet on the fourth level.

**step 7:** Follow the installation steps from page 24 to 50, taking into account that:

Only the SOUNDER, ALARM and FAULT outputs of the CAD-250 control panel are monitored, although it does not occupy the upper part. For the CAB-250B or CAB-250BLED expansion cabinets, it is not necessary to provide output wiring for the SND1, SND2, R.FAULT and R.ALARM outputs, as they do not have any function.

**8:** Once the system is started up and the parameters indicated in this guide are configured (see section XX), configure the control panel parameters so that the cabinets, control panel and expansion modules are interconnected correctly and the CAD-250 can recognise the rest of the totem control panels as expansions.

**SETTINGS (Main menu) > ADVANCED (Submenu)**

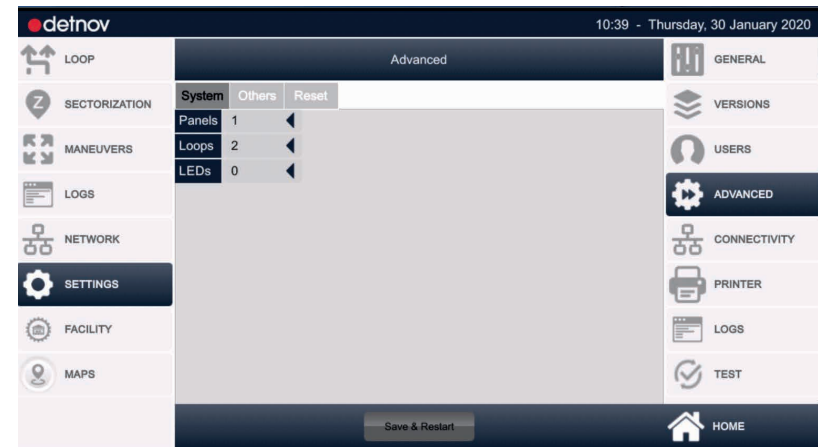

- 9. Expand the **PANELS** field and select the number of control panels that make up the totem.
- 10. Expand the **LOOPS** field and select the number of loops installed in the totem.
- 11. Activate the **BLED** switch if the control panel set includes a **CAD-250-BLED** expansion module.



## ANNEX 2: Compatible devices and consumption

Reference	Type	Standby consumption	Alarm consumption	Isolator	External power supply	Address no.	Description
DTD-210A	THERMAL.D	0.3 mA	3 mA	No	No	1	Addressable thermovelocimetric detector
DTD-215A	THERMAL.D	0.3 mA	3 mA	No	No	1	Addressable high temperature heat detector
DOD-220A	OPTICAL.D	0.3 mA	3 mA	No	No	1	Addressable optical detector
DOTD-230A	OPTICAL-THERMAL.D	0.3 mA	3 mA	No	No	1	Optical-thermal detector
DTD-210A-I	THERMAL.D	0.3 mA	3 mA	Yes	No	1	Addressable thermovelocimetric detector with isolator
DTD-215A-I	THERMAL.D	0.3 mA	3 mA	Yes	No	1	Addressable high temperature heat detector with isolator
DOD-220A-I	OPTICAL.D	0.3 mA	3 mA	Yes	No	1	Addressable optical detector with isolator
DOTD-230A-I	OPTICAL-THERMAL.D	0.3 mA	3 mA	Yes	No	1	Addressable thermovelocimetric detector with isolator
DGD-600	GAS	4.5 mA	65 mA	No	No	1	Light flammable gas detector, Methane, Natural Gas, Hydrogen
DGD-600-AC		3.5 mA	62 mA	No	No		
DGD-620	GAS	4.5 mA	65 mA	No	No	1	Heavy flammable gas detector, Liquefied Petroleum Gases, Propane, Butane
DGD-620-AC		3.5 mA	62 mA	No	No		
MAD-401	MOD	0.3 mA	1.5 mA	No	No	1	Addressable 1-input monitor module.
MAD-401-I	MOD	0.3 mA	1.5 mA	Yes	No	1	Addressable 1-input monitor module with isolator.
MAD-402	MOD	0.3 mA	1.5 mA	No	No	2	Addressable 2-input monitor module.
MAD-402-I	MOD	0.3 mA	1.5 mA	Yes	No	2	Addressable 2-input monitor module with isolator.
MAD-405-I	MOD	0.3 mA	1.5 mA	Yes	No	5	Addressable 5-input module with isolator.
MAD-409-I	MOD	0.3 mA	1.5 mA	Yes	No	10	Addressable 10-input module with isolator.
MAD-410-I	MOD	0.3 mA	1.5 mA	Yes	No	10	
MAD-411	MOD	0.3 mA	1.5 mA	No	No	1	Addressable 1-output control module.
MAD-411-I	MOD	0.3 mA	1.5 mA	Yes	No	1	Addressable 1-output control module with isolator
MAD-412	MOD	0.3 mA	1.5 mA	No	No	2	Addressable 2-output control module.
MAD-412-I	MOD	0.3 mA	1.5 mA	Yes	No	2	Addressable 2-output control module with isolator.
MAD-415-I	MOD	0.3 mA	1.5 mA	Yes	Yes	5	Addressable module of 5 relay outputs with isolator
MAD-419-I	MOD	0.3 mA	1.5 mA	Yes	Yes	10	Addressable module of 10 relay outputs with isolator.
MAD-421	MOD	0.3 mA	1.5 mA	No	No	2	Addressable 1-input monitor and control module.



Reference	Type	Standby consumption	Alarm consumption	Isolator	External power supply	Address no.	Description
MAD-421-I	MOD	0.3 mA	1.5 mA	Yes	No	2	Addressable 1-input monitor and control module with isolator.
MAD-422	MOD	0.3 mA	1.5 mA	No	Yes	4	Addressable monitor and control module with 2 relay inputs and 2 relay outputs
MAD-422-I	MOD	0.3 mA	1.5 mA	Yes	Yes	4	Addressable monitor and control module with 2 relay inputs and 2 relay outputs with isolator.
MAD-425-I	MOD	0.3 mA	1.5 mA	Yes	Yes	10	Addressable module with 5 technical inputs and 5 relay outputs
MAD-429-I	MOD	0.3 mA	1.5 mA	Yes	Yes	20	Addressable module with 10 technical inputs and 10 relay outputs
MAD-431	MOD	0.3 mA	1.5 mA	No	Yes	1	Addressable control module with 1 monitored 24 V output
MAD-431-I	MOD	0.3 mA	1.5 mA	Yes	Yes	1	Addressable control module with 1 monitored 24 V output with isolator
MAD-432	MOD	0.3 mA	1.5 mA	No	Yes	2	Addressable control module with two 24 V outputs
MAD-432-I	MOD	0.3 mA	1.5 mA	Yes	Yes	2	Addressable control module with two 24 V outputs with isolator
MAD-441	MOD	0.3 mA	1.5 mA	No	Yes	1	Addressable monitor module of 1 conventional zone.
MAD-441-I	MOD	0.3 mA	1.5 mA	Yes	Yes	1	Addressable monitor module of 1 conventional zone with isolator
MAD-442	MOD	0.3 mA	1.5 mA	No	Yes	2	Addressable monitor module of 2 conventional zones.
MAD-442-I	MOD	0.3 mA	1.5 mA	Yes	Yes	2	Addressable monitor module of 2 conventional zones with isolator
MAD-450	PUS	0.3 mA	1.5 mA	No	No	1	Addressable manual call point
MAD-450-I	PUS	0.3 mA	1.5 mA	Yes	No	1	Addressable manual call point with isolator
MAD-451-I	PUS	0.3 mA	1.5 mA	Yes	No	1	Resettable addressable manual call point with built-in isolator
MAD-450-IW	PUS	0.3 mA	1.5 mA	No	No	1	IP67 resettable addressable manual call point
MAD-461-I	SIR	0.3 mA	4.5 mA	Yes	No	1	Addressable sounder with isolator.
MAD-464-I	SIR	0.3 mA	6.5 mA	Yes	No	1	Addressable sounder with built-in isolator.
MAD-465-I	SIR	0.3 mA	6.5 mA	Yes	No	1	Sounder with addressable beacon with built-in isolator.
MAD-467-IC	SIR			Yes		1	Addressable red alarm sounder with white beacon for ceiling installation, with built-in isolator.
MAD-467-IW	SIR			Yes		1	Addressable red sounder alarm with white beacon, for wall installation, with built-in isolator
MAD-469-IC	SIR			Yes		1	Addressable white beacon with red base for ceiling installation with deep base, with built-in isolator.
MAD-469-IW	SIR			Yes		1	Addressable white beacon with red base for wall installation with deep base, with built-in isolator.
MAD-472	SIR	0.35 mA	7 mA	No		1	
MAD-473	SIR	0.35 mA	7.5 mA	No		1	Connection base with built-in sounder and addressable beacon.

Reference	Type	Standby consumption	Alarm consumption	Isolator	External power supply	Address no.	Description
MAD-481	MOD	0.3 mA	1.5 mA	No	Yes	1	Addressable control module with 1 voltage-free relay input of 240 Vac and 5 A.
MAD-490	ISO	0.3 mA		N/A	No	N/A	Isolator module
PAD-10	INDICATOR	0.625 mA	2.5 mA		No	1	Addressable remote indicator
T P L D - 1 0 0 (CCD-102)	PANEL ZONE	0.3 mA			No	3	Gateway card to the addressable loop for conventional control panels
T P L D - 1 0 0 (CCD-103)	PANEL ZONE	0.3 mA			No	7	Gateway card to the addressable loop for conventional control panels
T P L D - 1 0 0 (CCD-104)	PANEL ZONE	0.3 mA			No	5	Gateway card to the addressable loop for conventional control panels
T P L D - 1 0 0 (CCD-108)	PANEL ZONE	0.3 mA			No	9	Gateway card to the addressable loop for conventional control panels
T P L D - 1 0 0 (CCD-112)	PANEL ZONE	0.3 mA			No	13	Gateway card to the addressable loop for conventional control panels
RLI 3-30 V					No	N/A	Action indicator for embedding

## ANNEX 3: Loop calculation and batteries

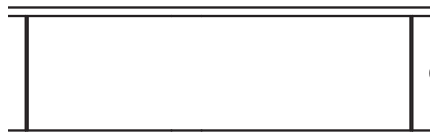
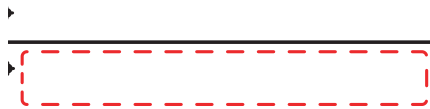
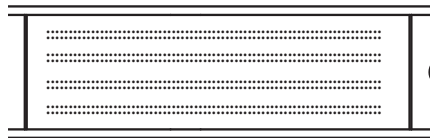
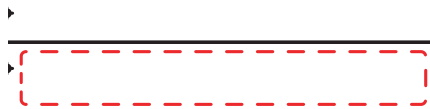
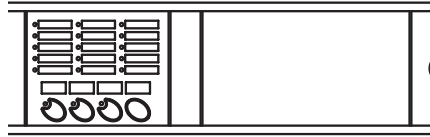
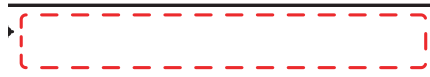

Both to comply with standards and with customer requirements in terms of system autonomy and with regards to avoiding exceeding the system performance, it is necessary to make the loop consumption and load calculation.

For this, Detnov provides a calculation tool that will facilitate this task for you in the design. In any case, we have included the theoretical basis of calculation so that you can check that your system will comply with the installation requirements.

1. You should determine the partial consumption of each cabinet, main control panel and expansions. Take into account that each cabinet includes its own power supply and will require its own batteries
2. Determine the system autonomy when in standby and in alarm, taking into account:

Expansion cards

The sounders connected to the panel outputs

The consumption on the auxiliary output

The total consumption of each loop with all planned devices.

3. Make the consumption calculation for each loop associated with its control panel section
4. Do not forget to include the expected consumption for the auxiliary sounder, relay outputs, etc. in the control panel consumption.

The minimum capacity required for a battery must be calculated using the equation (A.1):

$$C_{min} = (A1 \times t1 + A2 \times t2)$$

where:

**C<sub>min</sub>** is the minimum capacity required by the battery, in Ah;

**t1 and t2** are the emergency and alarm load times, in hours;

**A1** is the current absorbed by the system with the main power supply in fault state, but with the other functions in normal operating conditions (in amps);

**A2** is the alarm load (in amps).

Anticipating a loss of capacity due to ageing, the battery capacity in new condition should be  $1.25 \times C_{min}$ .

You can use the calculation tool available on our website, following the indications in this section and the recommendations of the UNE 23007-14 standard

The system autonomy must be:

Standby autonomy (h)	
72	After this time, it should be capable of supplying power for at least 30 min.
30	It is accepted if there is local or remote monitoring of the system, and there is a maximum repair contract of 24 hours.
4	If, in addition to the previous point, there is repair staff at all times and an emergency generator

It is necessary to correct the capacity calculation by + 25% in order to compensate the loss of capacity due to ageing.







