



PolyGard®2 GC-06

Digital Gas Controller Series

User Manual

November 2019 / Germany

Software Controller from version 1.01.07 with Display Version 1.02.12

Up-to-date data sheets and user manuals can be found in the download area of www.msr-24.com.

1	Application Intended for Use	4
2	Description	4
2.1	Normal Mode	4
2.2	Alarm Mode.....	4
2.3	Special Status Mode	5
2.3.1	Fault Mode	5
2.3.2	Restart Mode (Warm-up Operation)	5
2.3.3	Service Mode.....	5
2.3.4	UPS Functionality	5
3	Operating Instruction.....	6
3.1	Function of the Keys and LEDs at the Keypad	6
3.2	Setting / Changing of Parameters and Set Points	6
3.3	Code Levels.....	7
4	Menu Overview	8
4.1	Fault Management	9
4.1.1	Acknowledge a Fault	9
4.1.2	Error Memory	9
4.1.3	System Messages and Errors	9
4.2	Status Alarm.....	12
4.3	Status Relay	12
4.4	Menu Measuring Values.....	12
4.5	Maintenance Information.....	13
4.6	Menu Data Logger	14
4.6.1	Data Logger Switch On / Off.....	15
4.6.2	Current values.....	15
4.6.3	CV Log Rate	16
4.6.4	Alarm Status	16
4.6.5	Error Status	17
4.6.6	Relay Status	17
4.7	Display Parameters	18
4.7.1	Software Version.....	19
4.7.2	Language	19
4.7.3	Service Phone Number	19
4.7.4	System Time, System Date.....	19
4.7.5	X Bus Slave Address.....	19
4.7.6	LCD Function	20
4.7.7	WI Switching Times	20
4.8	Parameters	21
4.8.1	Service	22
4.8.2	Menu Relay Parameters	22
4.8.2.1	Relay Mode	24
4.8.2.2	Relay Operation Mode	24
4.8.2.3	Relay Function Static / Flash	24
4.8.2.4	Alarm Trigger Quantity	24
4.8.2.5	Horn Function (not safe output circuit because resettable)	24
4.8.2.6	External Override of Alarm / Signal Relay via DI.....	25
4.8.2.7	Delay Mode of Alarm / Signal Relay	26

4.8.2.8	OR Operation of Fault to Alarm / Signal Relay.....	26
4.8.2.9	OR Operation of Maintenance to Alarm / Signal Relay.....	26
4.8.3	Menu MP Parameters.....	26
4.8.3.1	Activate – Deactivate MP	28
4.8.3.2	Lock or Unlock MP.....	28
4.8.3.3	Selection Gas Type with Unit.....	28
4.8.3.4	Measuring Range Definition.....	32
4.8.3.5	Threshold / Hysteresis.....	32
4.8.3.6	Delay for Alarm ON and/or OFF for Current Value Evaluation	33
4.8.3.7	Average Overlay (VDI 2053 Functionality).....	33
4.8.3.8	Latching Mode Assigned to Alarm	33
4.8.3.9	MP Fault Assigned to Alarm.....	33
4.8.3.10	Alarm Assigned to Alarm Relay.....	33
4.8.3.11	MP Signal Assigned to Analog Output	33
4.8.4	Menu System Parameters.....	34
4.8.4.1	System Information	36
4.8.4.2	Maintenance Interval	36
4.8.4.3	Average Function	36
4.8.4.4	Power On Time	36
4.8.4.5	Deadband.....	37
4.8.4.6	Fault Activation by External DI	37
4.8.4.7	Special Function	37
4.8.4.8	Analog Output.....	39
4.8.4.9	Relay Multiplication	40
4.8.5	Operating Data.....	41
4.8.5.1	Operating Data of a Sensor Cartridge.....	42
4.8.5.2	Operating Data of a Sensor Board / EP-Module	43
4.8.5.3	Operating Data of a Gas Controller	43
4.8.6	Test Function of the Alarm and Signal Relays.....	44
4.8.7	Test Function of the Analog Outputs	45
5	Notes and General Information	46
5.1	Intended Product Application	46
5.2	Installer’s Responsibilities.....	46
5.3	Maintenance	46
5.4	Limited Warranty.....	46

Digital Gas Controller GC-06

1 Application Intended for Use

The PolyGard®2 GC-06 Gas Controller is used for monitoring, detection and warning of toxic and combustible gases and vapours in the ambient air. The GC-06 Gas Controller fulfils the requirements according to the European Standard EN 50545-1 for the stationary monitoring of carbon monoxide (CO), nitrogen dioxide (NO₂) and combustible gases in underground garages, tunnels, go-cart racecourses etc. The GC-06 Gas Controller also meets the requirements according to EN 378, VBG 20 and the guidelines "Safety requirements for ammonia (NH₃) refrigeration systems". The Gas Controller can be used as well for monitoring other gases and measuring values.

The intended sites are all areas being directly connected to the public low voltage supply, e.g. residential, commercial and industrial ranges as well as small enterprises (according to EN 5502). The Gas Controller may only be used in ambient conditions as specified in the Technical Data.

The PolyGard®2 Gas Controller GC-06 must not be used in potentially explosive atmospheres.

2 Description

The Gas Controller is a measuring, warning and control system for the continuous monitoring of different toxic or combustible gases and vapours as well as of Freons refrigerants. The GC-06 is suitable for the connection of up to 96 digital sensors like the PGSB_03 series via the 2-wire bus. Up to 32 analog inputs for the connection of sensors with 4 to 20 mA signal interface are available in addition. The controller can be employed as pure analog controller, as analog/digital or as digital controller. The total number of connected sensors, however, may not exceed 128 sensors.

Up to four programmable alarm thresholds are available for each sensor. For binary transmission of the alarms there are up to 32 relays with potential-free change-over contact and up to 96 signal relays.

Comfortable and easy operation of the Gas Controller is done via the logical menu structure. A number of integrated parameters enables the realisation of various requirements in the gas measuring technique. Configuration is menu-driven via the keypad. For fast and easy configuration, you can use the PC based configuration software **PCE06**.

Prior to commissioning please consider the guidelines for wiring and commissioning of the hardware.

2.1 Normal Mode

In normal mode, the gas concentrations of the active sensors are continuously polled and displayed at the LC display in a scrolling way. In addition, the controller continuously monitors itself, its outputs and the communication to all active sensors and modules.

2.2 Alarm Mode

If the gas concentration reaches or exceeds the programmed alarm threshold, the alarm is started, the assigned alarm relay is activated and the alarm LED (light red for alarm 1, dark red for alarm 2 + n) starts to flash. The set alarm can be read from the menu Alarm Status. When the gas concentration falls below the alarm threshold and the set hysteresis, the alarm is automatically reset. In latching mode, the alarm has to be reset manually directly at the alarm triggering device after falling below the threshold. This function is obligatory for combustible gases detected by catalytic bead sensors generating a falling signal at too high gas concentrations.

2.3 Special Status Mode

In the special status mode, there are delayed measurements for the operation side, but no alarm evaluation. The special status is indicated on the display and it always activates the fault relay. The yellow LED on the display is flashing.

The controller adopts the special status when:

- faults of one or more active devices occur,
- the operation starts up after return of voltage (power on),
- the service mode is activated by the user,
- the user reads or changes parameters,
- an alarm or signal relay is manually overridden in the alarm status menu or via digital inputs.

2.3.1 Fault Mode

If the controller detects an incorrect communication of an active sensor or module, or if an analog signal is outside the admissible range ($< 3.0 \text{ mA} > 21.2 \text{ mA}$), or if there are internal function errors coming from the self-control modules incl. watchdog and voltage control, the assigned fault relay is set and the error LED is constantly lit. The error is displayed in the menu Error Status in clear text. After removal of the cause, the error is automatically eliminated. The occurred and automatically reset errors are stored in the technician's menu where they have to be acknowledged manually.

2.3.2 Restart Mode (Warm-up Operation)

Gas sensors need a running-in period, until the chemical process of the sensor reaches stable conditions. During this running-in period the sensor signal can lead to an unwanted release of a pseudo alarm.

Depending on the connected sensor types, the longest warm-up time has to be entered as power-on time in the controller. This power-on time is started at the Gas Controller after switching on the power supply and/or after return of voltage. While this time is running out, the Gas Controller doesn't display any values and doesn't activate any alarms; the controller system isn't yet ready for use.

The power-on status occurs on the starting menu.

2.3.3 Service Mode

This operation mode includes commissioning, calibration, testing, repair and decommissioning.

The service mode can be enabled for a single sensor, for a group of sensors as well as for the complete system. In active service mode pending alarms for the concerned devices are held, but new alarms are suppressed.

2.3.4 UPS Functionality

The supply voltage is monitored in all modes. When reaching the battery voltage in the power pack, the UPS function of the controller is enabled (the menu Error Status shows the message "UPS available"), and the connected battery is charged.

Battery charging voltage (power supply voltage must be set to 27 V)

The GC-06 identifies $> 26 \text{ V}$ as charging situation and $< 26 \text{ V}$ as a power failure.

If the power fails, the battery voltage drops down and generates the power failure message.

At empty battery voltage, the battery is separated from the circuit (function of deep discharge protection). When the power is restored, there will be an automatic return to the charging mode.

If the GC-06 is to be operated without a battery, a supply voltage of $< 25 \text{ V}$ must be set at the power supply unit.





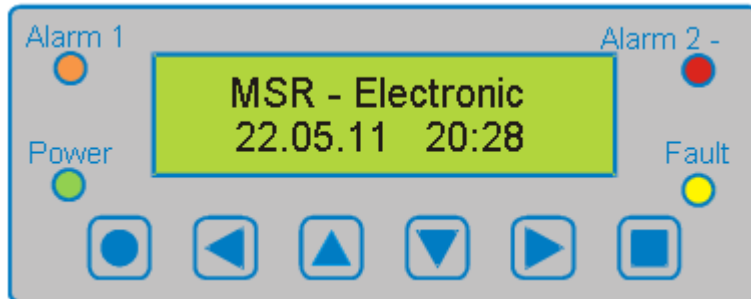

No settings and therefore no parameters are required for the UPS functionality.

3 Operating Instruction

The complete configuration and service are made via keypad user interface in combination with the LC display screen. Security is provided via three password levels against unauthorized intervention.



3.1 Function of the Keys and LEDs at the Keypad







-  Exits programming, returns to the previous menu level.
-  Enters sub menus and saves parameter settings.
-   Scrolls up & down within a menu, changes a value.
-   Moves the cursor position.

- LED light red: Flashes when alarm one or more alarms are active.
- LED dark red: Flashes when alarm two and alarms of higher priority are active.
- LED yellow: Flashes at system or sensor failure or when maintenance date exceeded or in voltage-free status with the option power failure flashing light.
- LED green: Power LED

3.2 Setting / Changing of Parameters and Set Points

-  Open desired menu window.
Code input field opens automatically, if no code is approved.

After input of valid code the cursor jumps onto the first position segment to be changed.

-   Push the cursor onto the position segment, which has to be changed.
-   Set the desired parameter / set point with the keys.
-  Save the changed value, confirm storage (ENTER).
-  Cancel storage / close editing / go back to next higher menu level (ESCAPE function).

3.3 Code Levels

According to the regulations of all national and international standards for gas warning systems, all inputs and changes are protected by a four-digit numeric code (= password) against unauthorised intervention. The menu windows of status messages and measuring values are visible without entering a code.

The release of a code level is cancelled if no button is pushed within 15 minutes.

The code levels are classified in order of priority: Priority 1 has top priority.

Priority 1: (code not changeable)

Code level priority 1 is intended for the service technician of the installer to change parameters and set-points. This password allows working on all settings. For opening the parameter menus, you must first activate the service mode after code release.

Priority 2: (code not changeable)

With code level priority 2, it is possible to lock / unlock transmitters temporarily. This password is only given to the end user by the installer in problem situations. In order to lock / unlock the sensors you must first activate the service mode after code release.

Priority 3: (code is settable in the maintenance information menu)

Inactive in delivery state, activated by entering a value. Same as priority 1 password, only changing the maintenance password is not possible.

Normally the code is only known to the service technician who has last changed it since it can be changed individually via priority 1.

Priority 4: (password 1234) (code not changeable)

Code level priority 4 allows the operator:

- to set date and time,
- to configure and to operate the data logger option,
after activation of the operation mode "Service Mode":
- to read all parameters,
- to manually operate test function of the alarm relays (functional test of the connected units),
- to manually operate test function of the analog outputs (functional test of the connected units).



4 Menu Overview

The Gas Controller GC-06 is operated via a clear, intuitive and logical menu structure. The operating menu contains the following levels:

- Starting menu with date and time if no MP is registered, otherwise scrolling display of the gas concentrations of all registered sensors in 5-second intervals. When ESC is pressed, the start menu with date and time is displayed for 10 seconds. If a submenu is not exited with ESC, DGC06 Display View returns to the starting menu after 15 minutes.
- Main menu
- Submenus 1 to 4

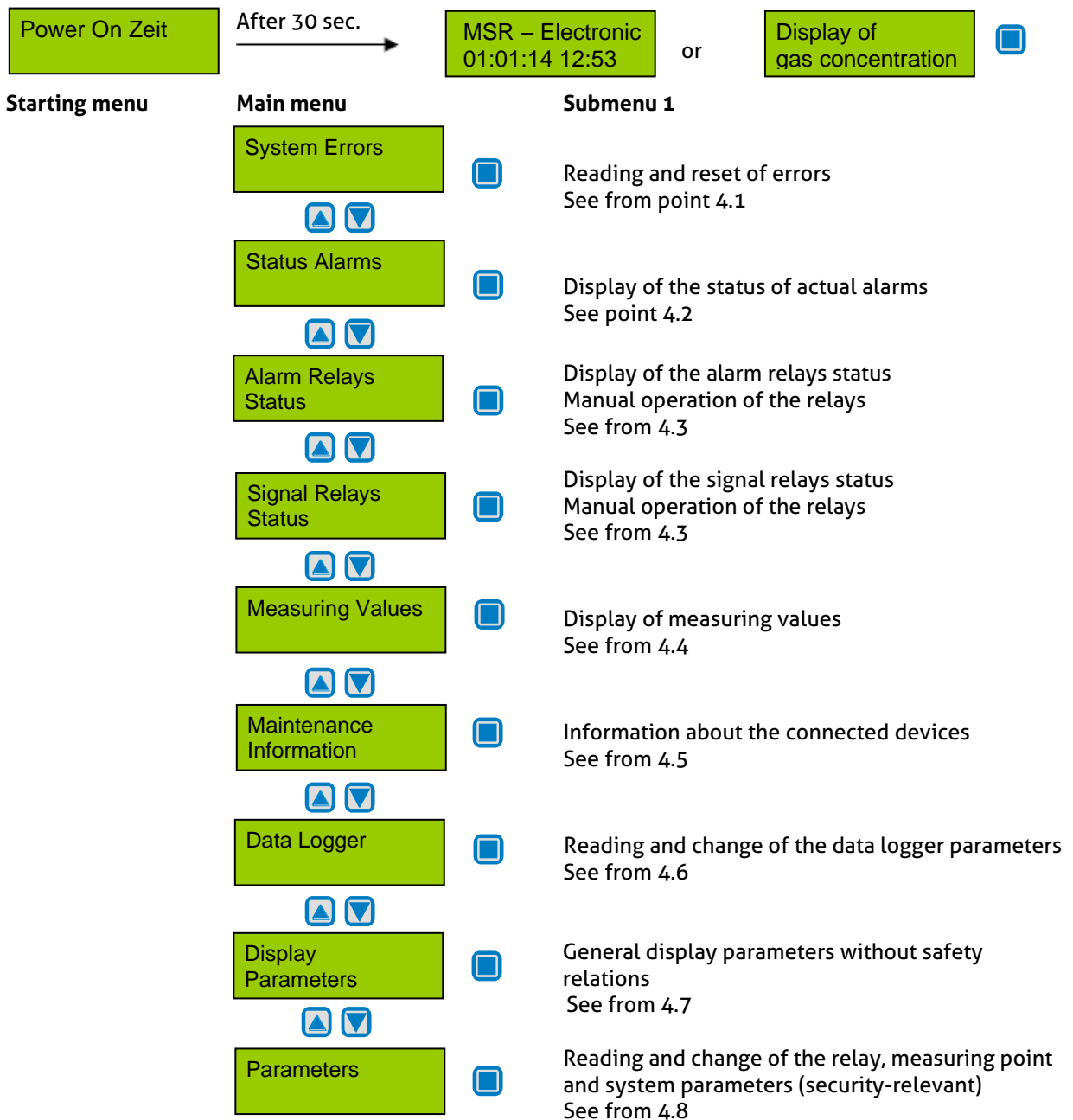

4.1 Fault Management

The integrated fault management records the first 99 faults with date and time stamps in the menu "System Errors". Additionally, a record of the faults occurs in the "Error memory", which can be read by anyone, but only reset by the service technician.

A pending fault activates the fault indication relay. The yellow LED (Fault) starts to flash; the fault is displayed in plain text with date and time in the starting menu.

In case of the fault of a connected sensor the alarms defined in the menu "MP Parameter" are activated in addition.

4.1.1 Acknowledge a Fault

According to the directives of the gas measuring technique, accumulated errors are allowed to be acknowledged automatically. The automatic acknowledgment of a fault is only possible after having removed the cause!

4.1.2 Error Memory

The menu "Error Memory" in the main menu "System Error" is visible without password.

In the error memory, the first 99 faults that have occurred and have already been acknowledged in the menu "System Error" are listed for the service technician in a power failure safe way. These can only be deleted by the code level priority 1.

Attention:

This memory should always be read during maintenance, relevant faults should be tracked and entered in the service logbook, and finally the memory should be emptied.

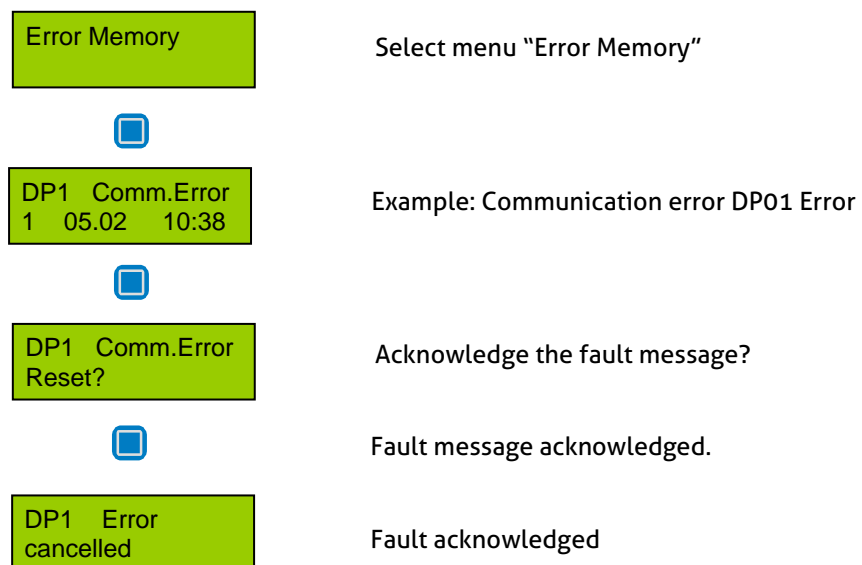

The errors are provided with a consecutive number. After an error has been cleared, all other errors automatically move up.

4.1.3 System Messages and Errors

The devices connected via the analog interface can only report their malfunction by signal underrange or overrange. The reason for signal underrange mostly comes from bad, wrong or missing signal wiring that is the reason for the error.

The following system error messages of the analog interface are detected and recorded.

"AP 0X Overrange" Current signal at analog input > 21.2 mA

Cause: Short-circuit at analog input, analog sensor not calibrated, or defective.

Solution: Check cable to analog sensor, make calibration, replace sensor.

"AP Underrange" Current signal at analog input < 3.0 mA

Cause: Wire break at analog input, analog sensor not calibrated, or defective.

Solution: Check cable to analog sensor, make calibration, replace sensor.

Any device with microprocessor and digital communication - such as digital heads, sensor boards, EP modules and even the controller - is equipped with extensive self-monitoring systems and diagnostic functions.

They enable detailed conclusions about the error causes and help the installers and operators to quickly determine the cause, and/or to arrange an exchange.

These errors can only be transmitted when the connection to the central (or tool) is intact.

"DP 0X Sensor" (0x8001) Sensor element at the sensor head – diagnostic function reports an error.

Cause: Sensor pins broken, mechanical or electrical damage

Solution: Exchange sensor head.

"DP 0X ADC Error" (0x8002) Monitoring of the amplifier and AD converter circuits at the input Device reports an error.

Cause: Mechanical or electrical damage of the amplifiers

Solution: Replace device.

"DP 0X Voltage" (0x8004) Monitoring of the sensor and/or process power supply, device reports an error.

Cause: Mechanical or electrical damage of the power supply

Solution: Measure tension if too low, replace device.

"DP 0X CPU Error" (0x8008) Monitoring of the processor function – reports an error.

Cause: Mechanical or electrical damage of the processor

Solution: Replace device.

"DP 0x EE Error" (0x8010) Monitoring of the data storage – reports an error.

Cause: Electrical damage of the memory or configuration error

Solution: Check configuration, replace device.

"DP 0X I/O Error" (0x8020) Power ON or monitoring of the in/outputs of the processor - reports an error.

Cause: During restart, electrical damage of the processor or of circuit elements

Solution: Wait until Power On is over, replace device.

"DP 0X Overtemp."(0x8040) Ambient temperature too high; the sensor outputs the measurement value for a determined period and switches to error state after 24 h.

Cause: Too high ambient temperature

Solution: Protect the device from direct sunlight or check climatic conditions.

"DP 0X Overrange"(0x8200) Signal of sensor element at the sensor head is out of range.

Cause: Sensor not calibrated correctly (e.g. wrong calibration gas), defective

Solution: Recalibrate sensor, replace it.

"DP 0X Underrange" (0x8100) Signal of sensor element at the sensor head is out of range.

Cause: Wire break at sensor element input, sensor drift too high, defective.

Solution: Recalibrate sensor, replace it.

The controller monitors the communication between request and response. If the reply is too late, incomplete or incorrect, the controller recognizes the following errors and reports them.

"SB 0X Comm.Error"	(0x9000) Communication error from central unit to SB 0X
Cause:	Bus line interrupted or short circuit, DP 0X registered at the controller, but not addressed. SB 0X defective.
Solution:	Check line to SB 0X, check SB address or MP parameters, replace sensor.
"DP 0X Comm.Error"	(0xB000) Communication error of SB to DP 0X sensor
Cause:	Bus line between SB and head interrupted or short circuit, DP 0X registered at the controller, but not configured at SB, wrong gas type, DP 0X defective.
Solution:	Check line to DP 0X, check sensor address or parameters, replace sensor.
"EP_06 0X Comm.Error"	(0x9000) Communication error to EP_06 0X module
Cause:	Bus line interrupted or short circuit, EP_06 0X registered at the controller, but not addressed or addressed incorrectly, EP_06 0X module defective
Solution:	Check line to EP_06 0X, check module address, replace module.
"Maintenance"	(0x0080) System maintenance is due.
Cause:	Maintenance date exceeded.
Solution:	Perform the maintenance.
"DP XX locked" "AP XX locked"	This MP input is locked (MP is physically present, but locked by the operator)
Cause:	Operator intervention.
Solution:	Eliminate the cause of a possible fault and then unlock the MP.
"UPS Error"	(0x8001) UPS doesn't work correctly, can only be signaled by the GC.
Cause:	Defective UPS – too high or too low voltage
Solution:	Replace UPS.
"Power Failure"	(0x8004) can only be signaled by the GC.
Cause:	Power failure or fuse tripped.
Solution:	Check power supply or fuses.
"Horn Error"	(0xA000) can only be signaled by the GC/EP with available hardware option.
Cause:	Wire break or device defective
Solution:	??
"Warning Sign Error"	(0x9000) can only be signaled by the GC/EP with available hardware option.
Cause:	Wire break or device defective
Solution:	??
"XXX FC: 0xXXXX"	Occurs, if there are several errors from one measuring point.
Cause:	Several causes
Solution:	See the specific errors.

4.2 Status Alarm

Display of the currently pending alarms in plain text, sorted by MP addresses. Only those measuring points are displayed, where at least one alarm is active. If no alarms are active, the text 'No alarms' is output. The alarms are generated either in the controller (alarm) or directly on site in the sensor / module (local alarm). Interventions are possible in this menu item only for the acknowledgment of latching alarms. Pending alarms cannot be acknowledged.

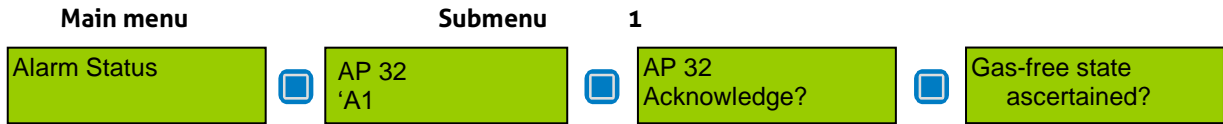

Acknowledge latching alarms.

Symbol	Description	Function
AP X	Measuring Point No.	Analog measuring point X = 1 - 32, where an alarm is pending.
DP X	Measuring Point No.	Digital measuring point X = 1 - 96, where an alarm is pending.
'A1	Alarm status	'A1 = Local alarm 1 active (generated in the sensor / module)
A1		A1 = Alarm 1 active (generated in the central control)
"A1		"A1 = Latching mode of Alarm 1 active (local/central no distinction)

4.3 Status Relay

Reading of the current status of alarm and signal relays.
The manual operation (test function) of the alarm and signal relays is done in the menu Parameters.

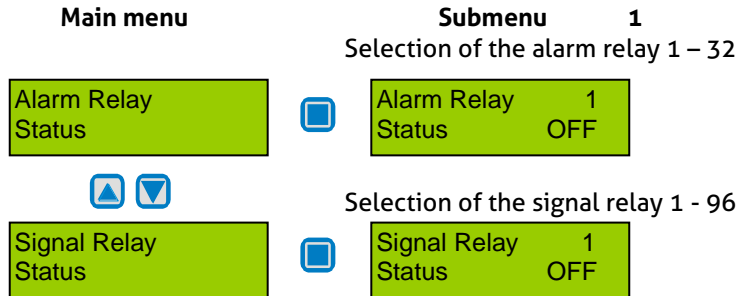

4.4 Menu Measuring Values

In this menu, the display shows the measuring value with gas type and unit. If the alarm evaluation is defined via the average, the display shows the current value (C) and additionally the average value (A).

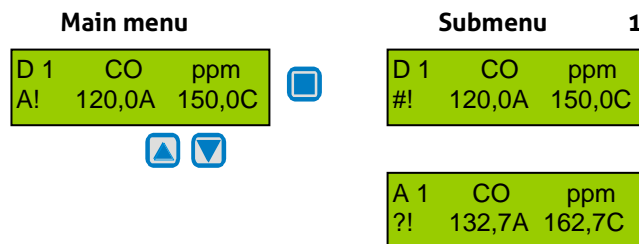

Symbol	Description	Default	Function
DX	Measured value		Measured value from bus sensor with MP address with X = 1-96
AX	Measured value		Measured value from analog sensor at analog input with AX = 1-32
CO	Gas type		See 4.7.3
ppm	Gas unit		See 4.7.3
A	Average value		Arithmetic average (30 measured values within the time unit)
C	Current value		Current value of gas concentration
A!	Alarm		MP has triggered an alarm
#	Maint. info		Device has exceeded maintenance date
?	ConfigError		MP configuration not compatible
\$	Local mode		Local special mode is active
Error	Fault MP		Communication error, or signal out of the measuring range
Locked	MP locked		MP was temporarily locked by the operator.

The information ConfigError has priority to maintenance information.

Alarm information is always displayed with „!“, even if ConfigError or maintenance information are active.

4.5 Maintenance Information

A control of the maintenance intervals required by law (SIL) or by the customer is integrated in the GC-06 system. When changing the maintenance intervals, you have to observe legal and normative regulations and the manufacturer's specifications! Always after that, a calibration must be performed so that the change can take effect.

System maintenance message:

At commissioning or after successful maintenance, the date (battery backed) for next due maintenance of the whole system has to be entered. When this date has been reached at 9 a.m., the maintenance message is activated.

Sensor maintenance message:

Sensors need regular calibration for complying with the specified accuracy and reliability. In order to avoid complex manual documentation, the sensors store their run time between the calibration intervals continuously and permanently. If the run time since the last calibration exceeds the sensor maintenance interval stored in the sensor, a maintenance message is sent to the central control.

The maintenance message is reset during calibration and the running time since the last calibration is set to zero.

Device reaction with pending maintenance message:

The maintenance signal can be ORed to each of the active relays in the menu Relay Parameters. In this way, one or more relays can be activated in case of maintenance (see 4.8.2.9).

In case of a pending maintenance message, the phone no. of the service company appears in the main menu instead of the time / date information and the yellow LED on the display is permanently lit.

The maintenance message can only be cleared by removing the cause - changing the maintenance date or calibration or replacement of the sensors. In order to distinguish between the sensor maintenance messages and the system maintenance message and to get a quick allocation of the serviceable sensors, the measured value in the menu item Measured Values gets the maintenance prefix "#".

As additional information, a separate window displays the time (in days) when the next sensor is due for maintenance. If several sensors are connected, the shortest time is always displayed. In the submenu, you can scroll through the display of all active measuring points to determine the sensors where the maintenance is due soon.

The largest representable number is 889 days (127 weeks / 2.5 years). If the next maintenance is due in an even longer period, the time display is still limited to 889 days.

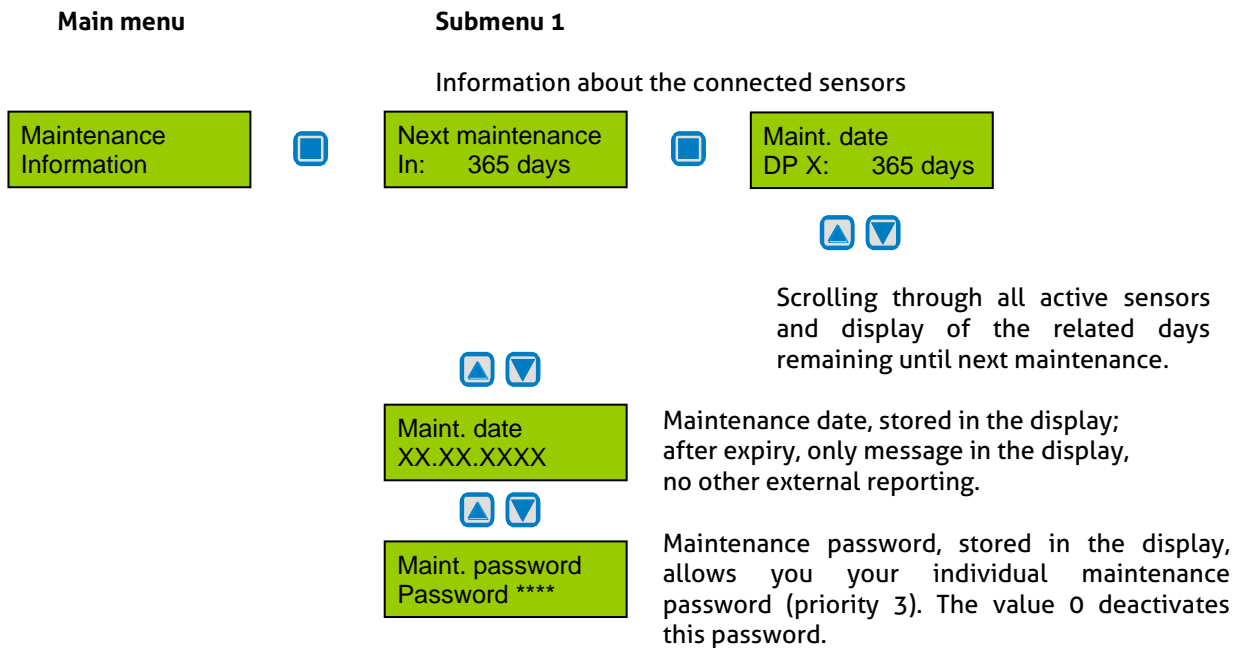

4.6 Menu Data Logger

Connect an USB device at the USB cable to use the data logger function.

This USB device may be for example an USB stick version 2.0 (not all types have been tested).

In this menu, the parameters for the long-term recording of the USB device are set.

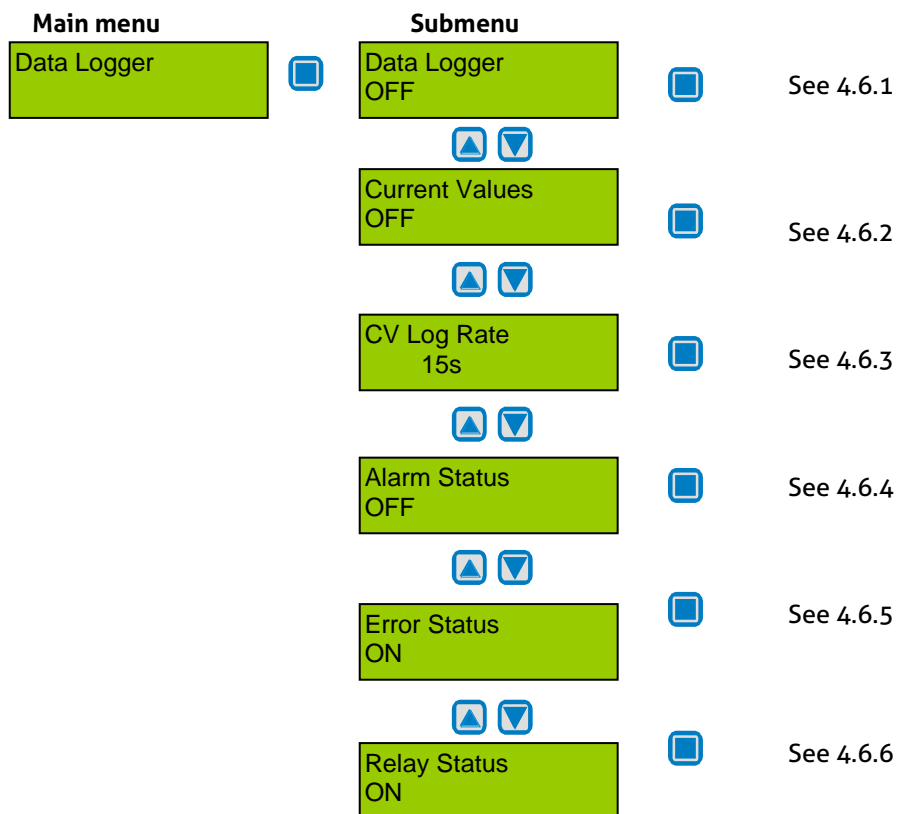

4.6.1 Data Logger Switch On / Off

Starting the logger function.

Symbol	Description	Default	Function
OFF	Turned off	OFF	OFF = Data Logger function is turned off ON = Data Logger function is turned on

Note:

This function only works with an USB device.

If this function is active, the USB device mustn't be removed, otherwise data may be lost!! (Like with Windows – safe removal of USB devices)

4.6.2 Current values

Symbol	Description	Default	Function
OFF	Current value	OFF	OFF = Current values of all registered MP are not recorded. ON = Current values of all registered MP are recorded.

Release of the current value recording of all active measuring points on the USB device in a CSV file. The file name is generated by the system and can't therefore be determined manually.

The name of the file is structured as follows:

CVMMTT.csv, with MM standing for the current month and TT standing for the current day.

Every day, a new file with the current date is generated. This makes sure that the files won't be too big to be still edited by established PC programs.

Internal structure of the file

(The headlines and column numbers are only for easy explanation and aren't written in the file!)

Column 1	2	3	4	5	6	7	..	98	99	100	Etc.
		1	2	3	4	5	...	96	97	98	x
Date	Time	DP1	DP2	DP3	DP4	DP5	...	DP96	AP1	AP2	
19_09_27	08_54_33	0	20	20	28	-	...	-	0	0	
19_09_27	08_54_44	0	20	20	28	-	...	-	25	29	
19_09_27	08_54_54	0	20	20	28	-	...	-	25	29	
19_09_27	08_55_05	0	20	20	28	-	...	-	25	29	
19_09_27	08_55_16	0	20	20	28	-	...	-	25	29	
19_09_27	08_55_27	0	20	20	28	-	...	-	25	29	
19_09_27	08_55_37	0	20	20	28	-	...	-	25	29	
19_09_27	08_55_49	0	20	20	28	-	...	-	25	29	
19_09_27	08_55_59	0	20	20	28	-	...	-	25	29	
19_09_27	08_56_10	0	20	20	28	-	...	-	25	29	
19_09_27	08_56_20	0	20	20	28	-	...	-	0	29	

The first column gives the time; from the second column on, the current values of all registered measuring points at this time are written. Inactive measuring points within active measuring points are marked by a dash -.

Values less than 0 stand for an error status of the measuring point.

e.g. 0x8100 = Underrange of head of measuring point

e.g. 0x8200 = Overrange of head of measuring point

e.g. 0x9000 = Communication error of sensor board of measuring point

e.g. 0xB000 = Communication error of head of measuring point

Each error is marked by the prefix 0x.

In this way the file keeps a fixed structure and can be evaluated with Excel and graphed according to the chronological progress.

4.6.3 CV Log Rate

Setting of the time interval in which the current values of all registered MP are stored (in seconds).

Symbol	Description	Default	Function
10s	Time in seconds	10s	Time interval between two entries in the CSV file (10- 9999 sec = approx. 2.7 h)

4.6.4 Alarm Status

Symbol	Description	Default	Function
OFF	Alarm status	OFF	OFF = Alarms aren't stored. ON = Alarms are stored.

Release of the alarm recording for all active measuring points on the USB device into a separate CSV file for alarms and faults.

The name of the file structured as follows:

AEMMTT.csv, with MM standing for the current month and TT standing for the current day.

Every day, a new file with the current date is generated. This makes sure that the files won't be too big to be still edited by established PC programs.

Internal structure of the file
(The headlines are not written in the file!)

Time	MP	Gas	Coming/ going	CV	AV	A1	A2	A3	A4
09_49_47	DP 02	CO	+	84	84	A1	A2		
09_49_47	AP 03	CO	+	194	194	A1	A2	A3	A4
09_50_02	DP 02	CO	-	20	20				
09_50_02	AP 03	CO	-	20	20				

The first column gives the time, the second the MP address and the third the gas type.

In the fourth column there is the information of coming (+) / going (-).

The fifth column displays the current value. In the sixth column there is the average value.

From the seventh to the tenth column you can find the active alarms.

All active alarms of the MP are always written if there is any change of an alarm. The reset of an alarm is documented by an empty column. This shows how long the alarm has been active.

4.6.5 Error Status

Symbol	Description	Setting Status	Function
OFF	Error status	OFF	OFF = Faults are not stored. ON = Faults are stored.

Release of the fault recording for all active measuring points on the USB device in the common CSV file for alarms and faults.

Internal structure of the file
(The headlines are not written in the file!)

Current time	Source	Error code	+ Error present - Error absent	Error date (month day) Time(hours minutes)	Error text
10_22_28	DP 79	0x8100	+	03_30 10_20	Underrange
13_48_28	DP 79	0x8100	-	03_30 13_46	Underrange

The first column gives the current time, the second one the error source. The third column indicates the error code.

In the fourth column there is the action:

+ = Error occurred.

- = Error acknowledged.

The fifth column gives the time and date when the error has occurred.

From the sixth column on, there is the plain text of the error code. If several errors are coded so you can read multiple entries here.

Every internal restart of the system (system reset) is also documented in the current day file.

Frequent reboots (several times per day) may point to a technical problem. Please consult the installer as soon as possible.

Info	Date	Time	
DGC-06 Reset	30_03_12	13_38_19	

4.6.6 Relay Status

Symbol	Description	Setting Status	Function
OFF	Relay status	OFF	OFF = Relay states are not stored. ON = Relay states are stored.

Release of the relay states recording for all relays on the USB device in the CSV file.

Internal structure of the file
(The headlines are not written in the file!)

Current time (column 1/A)	SR1 (column 2/B)	...to...	SR96 (column 97/CS)	AR1 (column 98/CT)	...to...	AR32 (column 129/DY)
10_22_28	1		0	0		1
13_48_28	0		0	0		0

0 = Relay not activated, 1 = Relay activated.

4.7 Display Parameters

In the menu Display Parameters, you can find the general, security irrelevant parameters of the gas controller. These parameters can be changed during the operation mode of the controller.

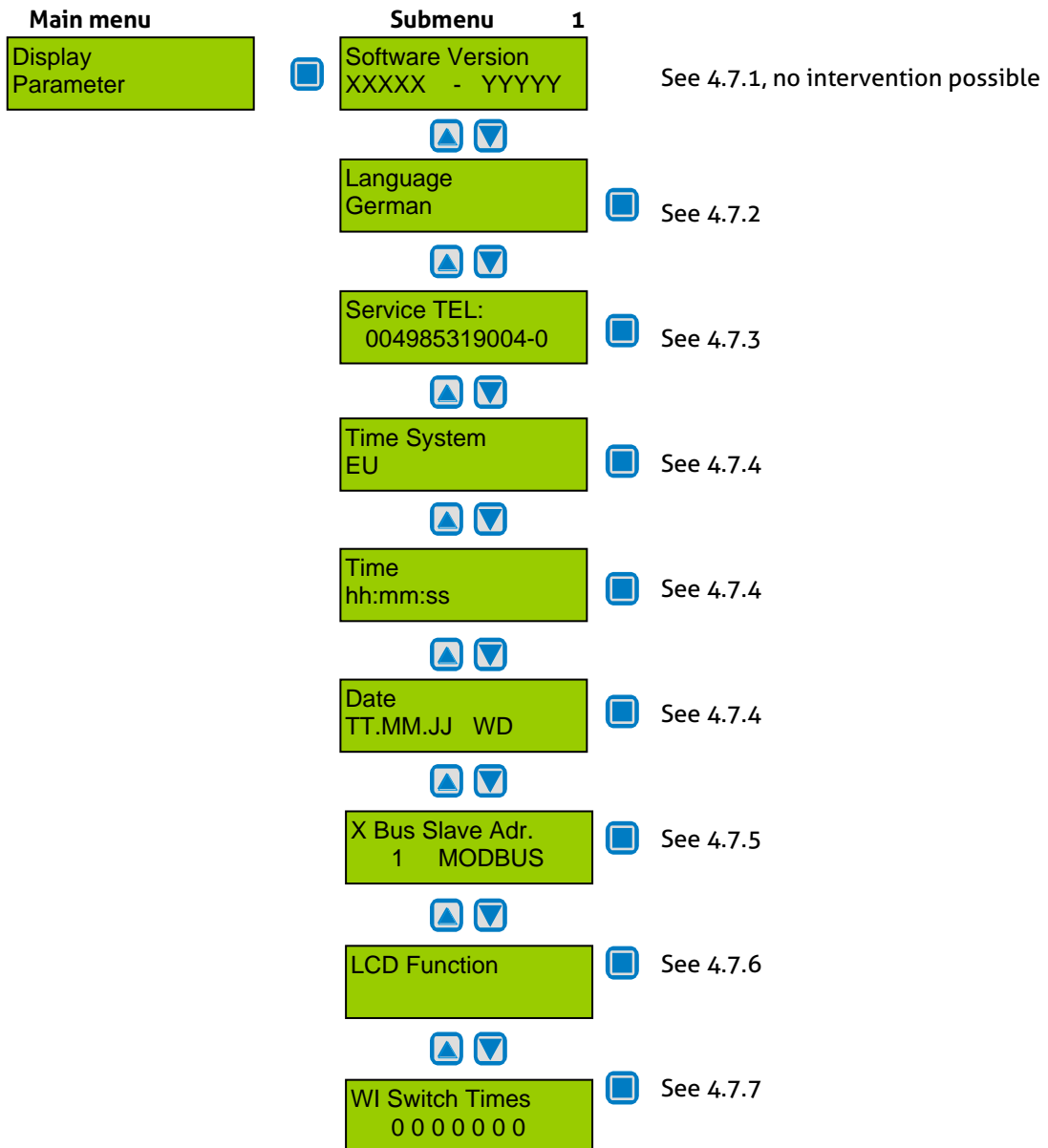

4.7.1 Software Version

Symbol	Description	Function
XXXXX	Software Version of the displays	XXXXX Software Version
YYYYY	Software Version of the basic board	YYYYY Software Version

4.7.2 Language

Selection of the menu language.

Symbol	Description	Default	Function
German	Language	German	German English USA English French Italian

4.7.3 Service Phone Number

The service phone no. can be entered individually in the next menu.

Symbol	Description	Default	Function
0853....	Phone No.		Input of the individual service phone no.

4.7.4 System Time, System Date

Input and correction of time and date. Selection of time and date format

Symbol	Descripti	Default	Function
EU	Time format	EU	EU = Display of time and date in EU format US = Display of time and date in US format
hh.mm.ss	Time		hh.mm.ss = Input of the correct time (EU format) hh.mm.ss pm = Input of the correct time (US format)
TT.MM.JJ WD	Date		TT.MM.JJ = Input of the correct date (EU format) MM.TT.JJ = Input of the correct date (US format) WD = Weekday, is automatically generated. * February is always represented with 28 days. Manual adjustment of the date in a leap year is required.

4.7.5 X Bus Slave Address

(only existing, if X Bus function is available)

Symbol	Description	Default	Function
Address	Slave address at the X Bus interface	1	Input of the slave address at the X bus. In addition to the address, the available option appears. Currently only Modbus available (pay attention to the

4.7.6 LCD Function

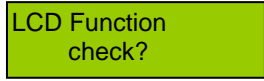

Testing the LCD hardware: For about two seconds, all the LEDs are lit. All points are displayed on the LCD.

4.7.7 WI Switching Times

The display on the DGC-06 can control a maximum of seven virtual digital inputs (WI stands for Watch Input) at the set times.

Since a virtual WI is considered an insecure input, it can only be used in the external override of relays during external ON (see 4.8.2.6).

In the main menu the current states of the WI are displayed:

- 0 = Inactive
- 1 = Active

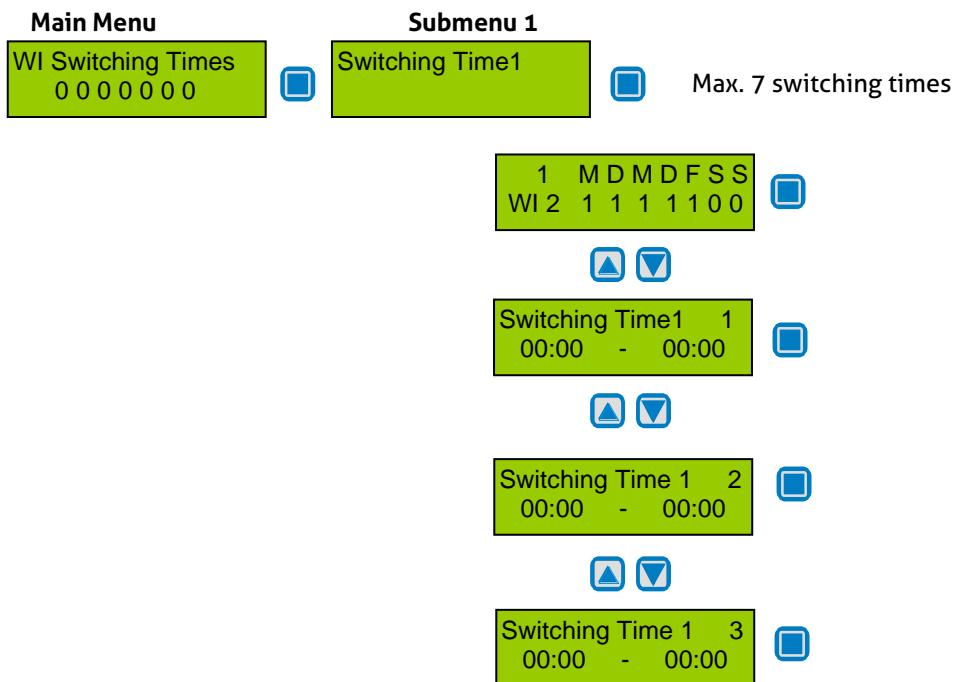

You can set up to seven different switching times, each with one WI and 3 time intervals. Thus, a maximum of 7 days can be configured with one WI or each weekday differently.

The time 00:00 - 00:00 is considered inactive. The three different times can be set only over the time of one day (24 hours).

4.8 Parameters

In the menu Parameters you can find the parameter functions of the gas controller.

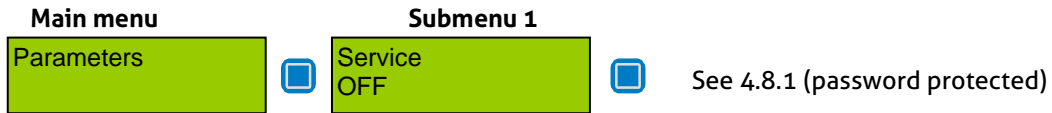

You can activate the following parameters only with Service ON.

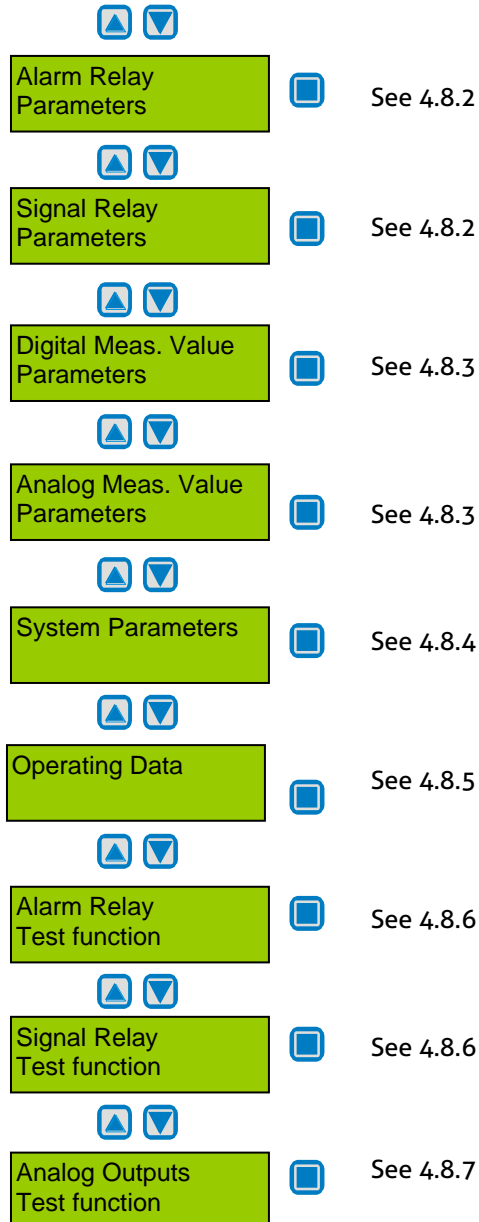

4.8.1 Service

Service and maintenance work mustn't be executed when the gas controller is in the normal measuring mode for it isn't sure that all response times and functions can be observed correctly. For calibration and service work you must first activate the special status mode on the controller. Only then you are permitted to change the safety related parameters. The special operating mode is activated by, among others, the function Service ON. After activation, the text 'Please wait...' is output. The readjustment can take up to 8 seconds (cycle time).

Further parameters menu items are therefore only accessible in the Service ON state. The Service ON state is reset to normal operation mode either automatically 15 minutes after the last key press or manually in the menu by the operator.

Sensors can't be switched into the "special mode" from the controller. It can only be done directly at the sensor using the tool. Sensors in the "special mode" are not included in the alarm evaluation.

Symbol	Description	Default	Function
OFF	Service	OFF	OFF = No reading and changing of parameters. ON = Controller in Special status mode, parameters can be read and changed.

4.8.2 Menu Relay Parameters

Reading and changing of the parameters separately for each relay.

Starting with software version 1.02.10 of the display, the DGC06 can display not only the parameters from the basic board, but also those from local devices such as the EP module or SB2.

However, the parameters from the local devices cannot be adjusted from the DGC06.

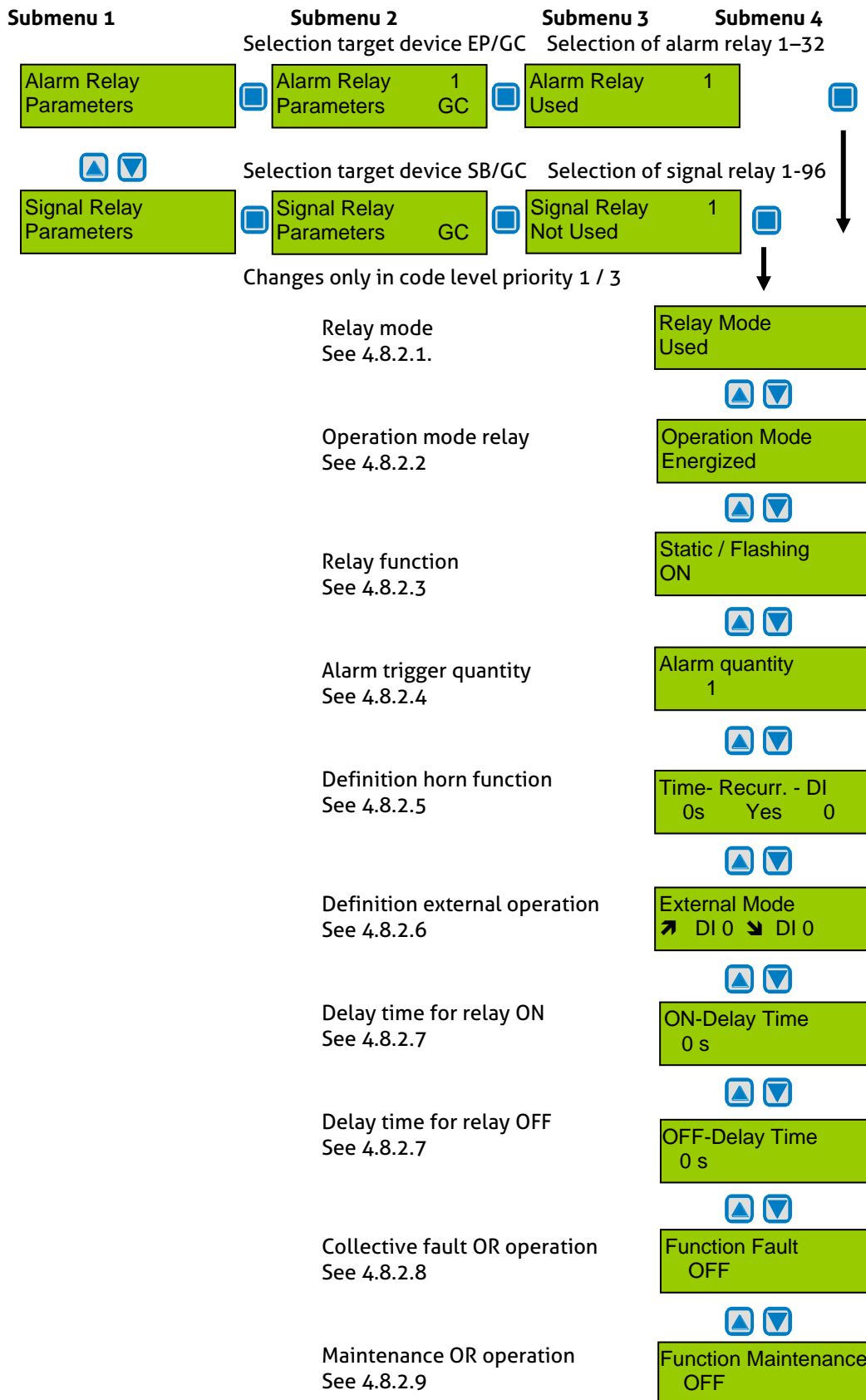

The Used / Not Used indication in the relay selection can only be displayed in GC level.

4.8.2.1 Relay Mode

Definition of the relay mode

Symbol	Description	Default	Function
Used	Mode	Used	Used = Relay is registered on the controller and can be used
			Not Used = Relay isn't registered on the controller

4.8.2.2 Relay Operation Mode

Definition of the relay operation mode

The terms energized / de-energized for this item come from the terms open-circuit and closed-circuit principle used for safety circuits. Here, however, not the relay contact circuit is meant (as a changeover contact, optionally available in the two principles), but the activation of the relay coil.

The LEDs attached to the modules show the two states in analogy. (LED off -> relay de-energized)

Symbol	Description	Default	Function
De-energ.	Mode	De-energ.	De-energ. = Relay (and LED) de-energized, if no alarm active
			Energized = Relay (and LED) permanently energized, if no alarm active

4.8.2.3 Relay Function Static / Flash

Definition of the relay function

The function "Flashing" represents a connection option for warning devices to improve visibility. If "Flashing" is set, this mustn't be used as a safe output circuit any more.

A combination of relay mode energized with flashing operation makes no sense and is therefore suppressed.

Symbol	Description	Default	Function
ON	Function	ON	ON = Relay function flashing at alarm (= time fixed 1 s) impulse / break = 1:1
			OFF = Relay function static ON at alarm

4.8.2.4 Alarm Trigger Quantity

In some applications it is necessary that the relay switches only at the nth alarm. Here you can set the number of alarms necessary for relay tripping.

Symbol	Description	Default	Function
Quantity	Function	1	Only if this quantity is reached, the relay trips. Maximum number is 9.

4.8.2.5 Horn Function (not safe output circuit because resettable)

The horn function is considered active if at least one of the two parameters (time or assignment to digital input) is set. The horn function retains its functionality even for alarms in latching mode.

Symbol	Description	Default	Function
Recurrence	Reset mode	0	0 = Reset of the relay after time having run out via DI (external) or by pushbuttons
Time		120	1 = After reset of the relay, time starts. At the end of the set time, Enter time for automatic reset function or recurrence function in s
DI		0	Assignment, which digital input resets the relay.

Horn function resettable:

The activated horn can be permanently reset with this function.

The following possibilities to acknowledge are available for the alarm relay as horn relay:

- By pressing the left button (ESC). Only available in starting menu.
- Automatic reset at the end of the preset time (active, if value > 0).
- By an external pushbutton (assignment of the appropriate digital input DI: 1-n).

Due to fixed polling cycles, external buttons must be pressed for a few seconds before the reaction occurs.

After successful acknowledgment the horn remains permanently reset until all assigned alarms for this relay function are inactive again. Only then it is triggered anew in case of an alarm.

Acknowledge the horn relay

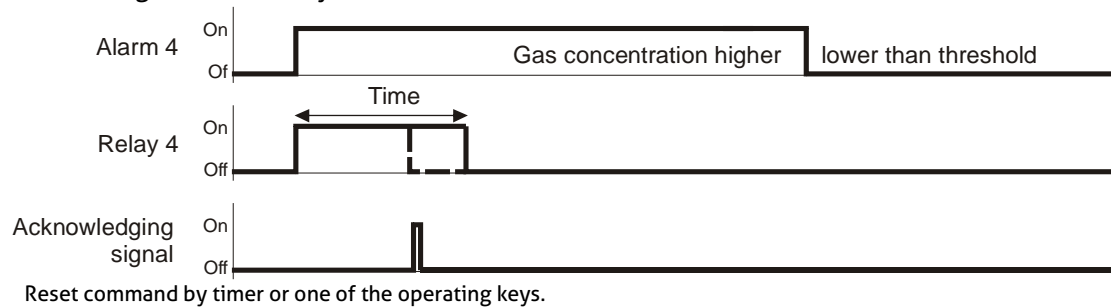

Special function Recurrence of the horn relay

After an alarm has been triggered, the horn will remain active until a reset action is done. After acknowledgment of the horn relay/s (clicking a button or via external input) a timer starts. When this time has run out and the alarm is still acting, the relay is set again. This process is repeated endlessly as long as the associated alarm remains active.

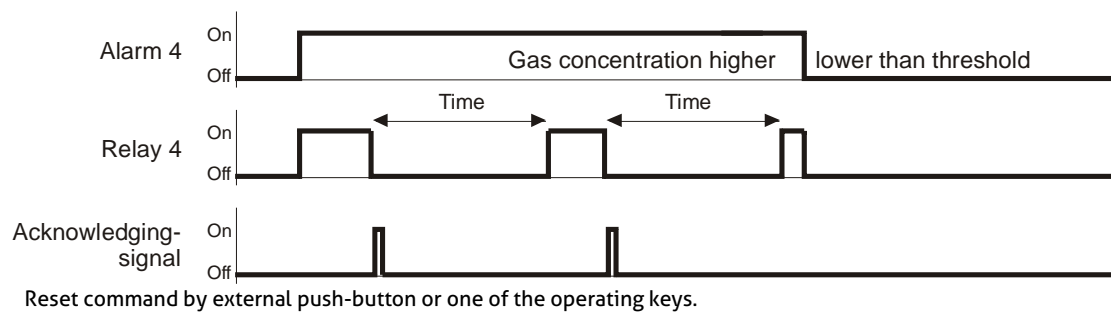

4.8.2.6 External Override of Alarm / Signal Relay via DI

Manual operation of the alarm relays via DI does not trigger the "special mode", as this is a deliberate and configured functionality. The use of the override should be used with caution, particularly the function of setting "external OFF".

Assignment of a digital input (DI) for the external switching on and off of the alarm relay.

This function has priority to gas alarm.

If External ON and External OFF are configured simultaneously to the same relay and both are active at the same time, so in this state, only the External OFF command is executed. In this mode, too, the relays work respecting the parameter settings "Static / Flash" and "energized / de-energized".

Symbol	Description	Default	Function
↗ DI 0	External ON	0	As long as DI 0 is closed, relay switches to ON
↘ DI 0	External OFF	0	As long as DI 0 is closed, relay switches to OFF

4.8.2.7 Delay Mode of Alarm / Signal Relay

Definition of the switch-on and switch-off delay of the relays

If the latching mode is set for this relay, the respective switch-off delay is without effect.

Symbol	Description	Default	Function
0 s	Switch-ON Delay Time	0	Alarm / Signal Relay is only activated at the end of the defined time. 0 sec. = No delay
0 s	Switch-OFF Delay Time	0	Alarm / Signal Relay is only deactivated at the end of the defined time. 0 sec. = No delay

4.8.2.8 OR Operation of Fault to Alarm / Signal Relay

Enables or disables the Fault OR operation of the current alarm / signal relay.

If the OR operation for this relay is set to active = 1, all device faults will activate the output in addition to the alarm signals.

In practice, this ORing will be used if, for example, fans should run or warning lights should be activated in case of device malfunction, since the fault message of the central control is not permanently monitored.

Note:

Exceptions are all errors of the measurement point because the MPs can be assigned to each alarm separately in the menu MP Parameters. This exception is used to build up targeted zone related signaling in case of MP errors, which should not affect other zones.

Symbol	Description	Default	Function
OFF	No assignment	OFF	Alarm and/or signal relay isn't affected if a device fault occurs.
ON	Activated assignment	OFF	Alarm and/or signal relay turns on if a device fault occurs.

4.8.2.9 OR Operation of Maintenance to Alarm / Signal Relay

Enables or disables the Maintenance OR operation of the current alarm / signal relay.

If the OR operation for this relay is set to active = 1, the output will be activated in addition to the alarm signals when at least one maintenance message is pending.

In practice, this ORing will be used if, for example, fans should run when the sensor accuracy isn't ensured anymore because of missing calibration (therefore pending maintenance message) or warning lights should be activated, since the maintenance information of the central control is not permanently monitored.

Note:

Resetting of the activated maintenance message is only possible by calibration of the sensors or by disabling this OR function.

Symbol	Description	Default	Function
OFF	No assignment	OFF	Alarm and/or signal relay isn't affected if a maintenance message occurs.
ON	Activated assignment	OFF	Alarm and/or signal relay turns on if a maintenance message occurs.









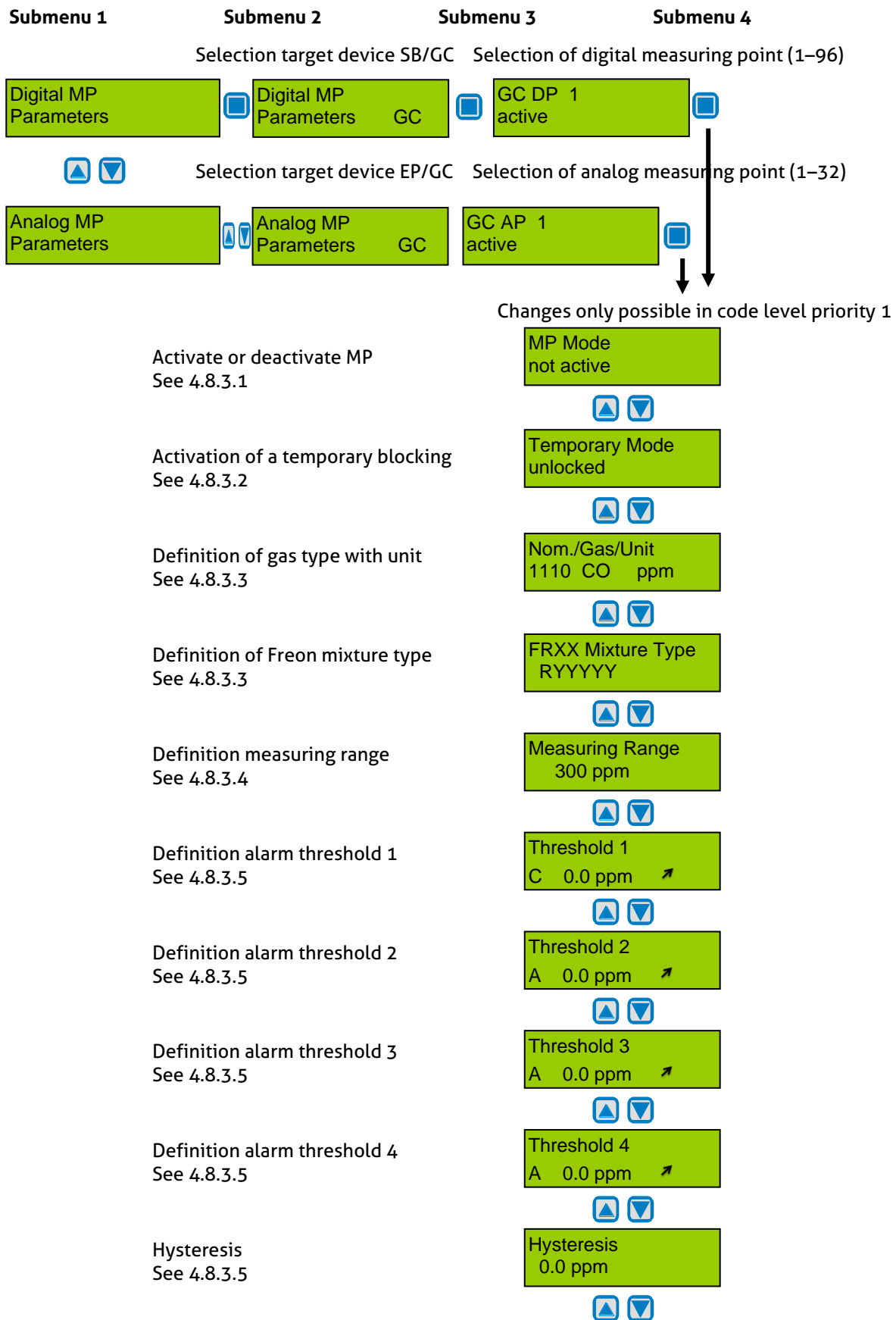



4.8.3 Menu MP Parameters

For reading and changing measuring point parameters for each bus and analog sensor including registration of MP and assignment of the alarm relays.

Starting with software version 1.02.10 of the display, the DGC06 can display not only the parameters from the base board, but also those from local devices such as the EP module or SB2.

However, the parameters from the local devices cannot be adjusted from DGC06.



Delay time for alarm ON See 4.8.3.6	CV Alarm ON delay 0 s
	 
Delay time for alarm OFF See 4.8.3.6	CV Alarm OFF delay 0 s
	 
Average value overlay See 4.8.3.7	AV Overlay No
	 
Definition of latching mode See 4.8.3.8	Alarm - 1 2 3 4 LM - 0 0 0 0
	 
Assign MP fault to alarm See 4.8.3.9	Alarm - 1 2 3 4 Fault - 0 0 0 0
	 
Assign alarm to alarm relay See 4.8.3.10	A1 A2 A3 A4 0 0 0 0
	 
Assign MP signal to analog output X or / and Y See 4.8.3.11	Analog Output x y

4.8.3.1 Activate – Deactivate MP

Deactivation shuts the registered / not registered sensor down in its function, which means that there is no alarm or fault message at this measurement point. Existing alarms and faults are cleared with deactivation. Deactivated sensors do not output a collective fault message.

Symbol	Description	Default	Function
active	MP Mode	Not active	active = Measuring point activated at the controller. not active = Measuring point not activated at the controller.

4.8.3.2 Lock or Unlock MP

In the temporary Lock Mode, the function of the registered sensors is put out of service, which means that there is no alarm or fault message at this measuring point. Existing alarms and faults are cleared with the locking. If at least one sensor is blocked in its functionality, the collective fault message is activated after expiry of the internal fault delay time, the yellow fault LED is flashing, and a message appears in the menu System Errors.

Symbol	Description	Default	Function
unlocked	Lock mode	unlocked	unlocked = MP free, normal operation locked = MP locked, SSM (collective fault message) active

4.8.3.3 Selection Gas Type with Unit

Selection of the desired and connected gas sensor type (connection possible as digital sensor cartridge SC, SX or analog measuring signal MC2)

The selection contains all necessary information for the controller, and is also used for comparing the real, digital data with the settings.

This feature increases the user and operating security.

There is an entry available per gas type for each unit; at the moment there are 97 selection options.

MSR Code	Sensor Head Type SC2-, SX1-, MC2-	Gas Type	Formula	Meas. Range ¹	Unit
1110	E1110-X	Carbon monoxide	CO	0-300	ppm
1130	E1130-X	Nitrogen dioxide	NO ₂	0-30	ppm
3480	P3480-A	Propane	C ₃ H ₈	0-100	% LEL
3400	P3400-A	Methane	CH ₄	0-100	% LEL
3440	P3440-A	Hydrogen	H ₂	0-100	% LEL
3408	P3408-A	Ammonia	NH ₃	0-100	% LEL
3485	P3485-A	Acetone	(CH ₃) ₂ CO	0-100	% LEL
3430	P3430-A	Benzene	C ₆ H ₆	0-100	% LEL
3425	P3425-A	Ethyl alcohol	C ₂ H ₅ OH	0-100	% LEL
3427	P3427-A	Ethyl acetate	CH ₃ COOC ₂ H ₅	0-100	% LEL
3410	P3410-A	Ethylene	C ₂ H ₄	0-100	% LEL
3460	P3460-A	n-Butane	C ₄ H ₁₀	0-100	% LEL
3491	P3491-A	n-Heptane	C ₇ H ₁₆	0-100	% LEL
3435	P3435-A	n-Hexane	C ₆ H ₁₄	0-100	% LEL
3482	P3482-A	Isopropyl alcohol	C ₃ H ₈ O	0-100	% LEL
3498	P3498-A	JP8	JP8	0-100	% LEL
3450	P3450-A	Methanol	CH ₃ OH	0-100	% LEL
3458	P3458-A	Methyl ethyl ketone MEK	C ₄ H ₈ O	0-100	% LEL
3470	P3470-A	n-Octane	C ₈ H ₁₈	0-100	% LEL
3475	P3475-A	n-Pentane	C ₅ H ₁₂	0-100	% LEL
3490	P3490-A	Toluene	C ₇ H ₈	0-100	% LEL
3448	P3448-A	Butyl acetate	C ₆ H ₁₂ O ₂	0-100	% LEL
3415	P3415-A	Cyclohexane	C ₆ H ₁₂	0-100	% LEL
3472	P3472-A	Cyclopentane	C ₅ H ₁₀	0-100	% LEL
3420	P3420-A	Ethane	C ₂ H ₆	0-100	% LEL
3468	P3468-A	Isobutanol	C ₂ H ₆ O ₂	0-100	% LEL
3473	P3473-A	Methyl acetate	C ₃ H ₆ O ₂	0-100	% LEL
3495	P3495-A	Nonane	C ₉ H ₂₀	0-100	% LEL
3402	P3402-A	LPG	LPG	0-100	% LEL
3496	P3496-A	Petrol Vapours	Petrol	0-100	% LEL
3497	P3497-A	Styrene	C ₈ H ₈	0-100	% LEL
3493	P3493-A	Xylene	C ₈ H ₁₀	0-100	% LEL
3480	P3480-C	Propane	C ₃ H ₈	0-5000	ppm
3494	P3494-A	Butadiene	C ₄ H ₆	0-100	% LEL
3405	P3405-A	Acetylene	C ₂ H ₂	0-100	% LEL
I400	I3400-A	IR-Methane	CH ₄	0-100	% LEL
I400		IR-Methane	CH ₄	0-100	% Vol
I500		IR-Methane	CH ₄	0-100	% LEL
I500		IR-Methane	CH ₄	0-100	% Vol
S400	??	IR-Methane	CH ₄	0-100	% LEL
I480	I3480-A	IR-Propane	C ₃ H ₈	0-100	% LEL
I480		IR-Propane	C ₃ H ₈	0-100	% Vol
I580		IR-Propane	C ₃ H ₈	0-100	% LEL

I580		IR-Propane	C ₃ H ₈	0-100	% Vol
S480	??	IR-Propane	C ₃ H ₈	0-100	% LEL
I495		Acetylene	C ₂ H ₂	0-100	% LEL
I595		Acetylene	C ₂ H ₂	0-100	% LEL
1129	E1129-X	Nitrogen monoxide	NO	0-100	ppm
1195	E1195-X	Oxygen	O ₂	0-25	% Vol
1125	E1125-X	Ammonia	NH ₃	0-300	ppm
I464	I1464	Carbon dioxide	CO ₂	0-2000	ppm
I564	I1564	Carbon dioxide	CO ₂	0-2000	ppm
S164	I1164-A	Carbon dioxide	CO ₂	0-2000	ppm
I464	I1464	Carbon dioxide	CO ₂	0-5	% Vol
I564	I1564	Carbon dioxide	CO ₂	0-5	% Vol
S164	I1164-B; -C	Carbon dioxide	CO ₂	0-5	% Vol
C160		VOC	VOC	0-2000	ppm
2189	S2189-A	Ethylene	C ₂ H ₄	20-2000	ppm
2125	S2125-C / F	Ammonia	NH ₃	0-3000	ppm
2053		Xylene	C ₈ H ₁₀	0-300	ppm
D184		Sulphur hexafluoride	SF ₆	0-1000	ppm
1199	E1199-X	Ethyleneoxid	C ₂ H ₄ O	0-10	ppm
1184		Arsine	AsH ₃	0-1	ppm
1135	E1135-X	Bromine	Br ₂	0-2	ppm
1182	E1182-X	Hydrogen fluoride	HF	0-10	ppm
1192	E1192-X	Nitrous oxide	N ₂ O	0-2000	ppm
1183	E1183-X	Hydrogen cyanide	HCN	0-100	ppm
1185	E1185-X	Formaldehyde	CH ₂ O	0-10	ppm
1186	E1186-X	Silane	HCL	0-20	ppm
1188	E1188-X	Ethylene	SiH ₄	0-50	ppm
1189	E1189-X	Ozone	C ₂ H ₄	0-200	ppm
1190	E1190-X	Chlorine	O ₃	0-200	ppm
1193	E1193-X	Sulphur dioxide	CL ₂	0-20	ppm
1196	E1196-X	Hydrogen sulphide	SO ₂	0-100	ppm
1197	E1197-X	Fluorine	H ₂ S	0-200	ppm
1198	E1198-X	Phosphine	F ₂	0-2	ppm
1187	E1187-X	Hydrogen	PH ₃	0-5	ppm
1194	E1194-X	Chlorine dioxide	H ₂	0-1000	ppm
1181	E1181-X	Nitrous oxide	ClO ₂	0-1	ppm
1147	E1147-X	Phosgene	COCl ₂	0-1	ppm
2059		FR01(R12)	FR01 R12		ppm
2061	2061-XX	FR02(R23)	FR02 R23 R508b	20-2000	ppm
2063	2063-XX	FR03(R1234yf)	FR03 R1234yf R452a R513a R454b R454c R455a R1234ze	20-2000	ppm

2064	2064-XX	FR04(R123)	FR04 R123 R1233zd	20-2000	ppm
2066		FR05(R11)	FR05 R11	20-2000	ppm
2070	2070-XX	FR06(R22)	FR06 R22 R401a R401b R402a R402b R403a R408a R409a R411a	20-2000	ppm
2077	2077-XX	FR07(R134a)	FR07 R134a R407a R407f R416a R417a R422a R422d R427a E437a R438a R449a R450a	20-2000	ppm
2080	2080-XX	FR08(R407c)	FR08 R32 R125 R143a R404a R407c R410a R434a R448a R452b R507a	20-2000	ppm
2020	2020-XX	FR LFL	FR LFL R32 R454b R455a R1234yf R1234ze	0-50	% LEL
EXT		Temperature	Temp	°	°C
EXT		Temperature	Temp	°	°F
EXT		Humidity	Humidity		% RH
EXT		Pressure	Pressure		mbar
EXT		TOX	TOX		ppm
EXT		Combustible	Comb.		% LEL
EXT		External	External		%
EXT		Digital ³	Digital		%

¹ Different measuring ranges are possible, but not listed here. For details see the sensor datasheets.

² Oxygen measurements: Alarm at falling concentration

³ The use with the measuring range value: 1 results in a binary value output of the values 0 or 1.

Menu is only displayed if a Freon group is selected as the gas type. In the second line then the actual Freon designation is entered. These freons are listed in the previous table under the Freon groups in the column FORMULA.

FRXX Mixture Type
RYYYYY

4.8.3.4 Measuring Range Definition

The measurement range must be adapted to the working range of the connected gas sensor.

For additional control by the installer, the settings in the controller must mandatorily match with the used sensors. If the types of gas and/or measurement ranges of the sensor don't agree with the settings of the controller, the error "EEPROM / configuration error" is generated, and the collective fault message is activated.

The range also affects the display of the measured values, alarm thresholds and hysteresis. For measuring ranges <10 three decimals places, <100 two decimal places, <1000 one decimal place are displayed. For measuring ranges ≥ 1000, the display is without decimal place. The resolution and accuracy of the calculation is not affected by the different measuring ranges. The measuring range can only be set with the upper 2 digits (internal scaling). The maximum adjustable value of the measuring range is 20,000.

4.8.3.5 Threshold / Hysteresis

For each measuring point four alarm thresholds are available for free definition. If the gas concentration is higher than the set alarm threshold, the associated alarm is activated. If the gas concentration falls below the alarm threshold inclusive hysteresis the alarm is again reset. In the mode "Alarm at falling" the corresponding alarm is set in case of falling below the set alarm threshold and reset again when exceeding the threshold plus hysteresis. The display depends on the set measuring range: see 4.8.3.4. Unused alarm thresholds must be defined with 0, in order to avoid undesired alarms. Higher-level alarms automatically activate the lower-level alarms. Therefore, the thresholds and hysteresis are only accepted if a few simple rules are observed:

1. The thresholds must be ≤ measuring range, but not more than 16,000.
2. For increasing thresholds, the threshold values must also be indicated in ascending order.
3. For falling thresholds, the threshold values must also be indicated in descending order.
4. In case of mixed settings e.g. for O₂, first the falling thresholds and then the increasing thresholds must be indicated.
5. The hysteresis must not be 0 if at least one threshold is set. If this occurs, DGC06 calculates the smallest possible hysteresis and stores it.
6. The maximum hysteresis can be as large as half of the smallest threshold. DGC06 also limits the hysteresis when saving.

Symbol	Description	Default	Function	Symbol
A	Evaluation	A	A C	A = Alarm evaluation with average value of MP C = Alarm evaluation with current value of MP
80 ppm	Alarm threshold	40 80 100 120 15	Threshold 1 Threshold 2 Threshold 3 Threshold 4 Hysteresis	Gas concentration > Threshold 1 = Alarm 1 Gas concentration > Threshold 2 = Alarm 2 Gas concentration > Threshold 3 = Alarm 3 Gas concentration > Threshold 4 = Alarm 4 Gas concentration < (Threshold X –Hysteresis) = Alarm X OFF
↗		↗		↗ = Alarm release at increasing concentrations ↘ = Alarm release at falling concentrations

4.8.3.6 Delay for Alarm ON and/or OFF for Current Value Evaluation

Definition of delay time for alarm ON and/or alarm OFF. The delay applies to all alarms of an MP with current value evaluation, not with average value overlay, see 4.8.3.7.

Symbol	Description	Default	Function
0 s	CV Alarm ON delay	0	Gas concentration > Threshold: Alarm is only activated at the end of the fixed time (sec.). 0 sec. = No delay
0 s	CV Alarm OFF delay	0	Gas concentration < Threshold: Alarm is only deactivated at the end of the fixed time (sec.). 0 sec. = No delay

4.8.3.7 Average Overlay (VDI 2053 Functionality)

The alarm evaluation of the operation mode "Average" is overridden by the current value, if this exceeds the alarm threshold defined in the menu "System Parameters AV Overlay" (see 4.8.4.4). The overlay is delayed by the time factor entered in the local menu. The function of the average overlay is only evaluated for the gas type CO and is activated here.

Symbol	Description	Default	Function
Yes	AV Overlay	Yes	Yes = Average overlay active (for CO) No = Average overlay not active

4.8.3.8 Latching Mode Assigned to Alarm

In this menu you can define, which alarms should work in latching mode.

Symbol	Description	Default	Function
Alarm - 1 2 3 4 SBH - 0 0 0 0	Latching MP	0 0 0 0	0 = No latching 1 = Latching

4.8.3.9 MP Fault Assigned to Alarm

In this menu you can define, which alarms should be activated by a fault at the measuring point.

Symbol	Description	Default	Function
Alarm - 1 2 3 4 Fault - 1 1 0 0	Fault MP	1 1 0 0	0 = Alarm not ON at MP fault 1 = Alarm ON at MP fault

4.8.3.10 Alarm Assigned to Alarm Relay

Each of the four alarms can be assigned to any physically existing alarm relay 1 to 32 or signal relay R1 to R96. Unused alarms aren't assigned to an alarm relay.

Symbol	Description	Default	Function
0	A1 A2 A3 A4	0 0 0 0	RX = Assignment of the alarms A1 - A4 to the signal relays R1-R96 X = Assignment of the alarms A1 - A4 to the alarm relays 1-32

4.8.3.11 MP Signal Assigned to Analog Output

The measuring point signal (current or average value) can be assigned to one of the max. 16 analog outputs.

The same assignment to different outputs (8) generates a functional duplication. This is often used to control remote devices in parallel (supply fan in the basement, exhaust fans on the roof).

If several assignments are made to one analog output, the output signal is output **WITHOUT** fault information. It should be noted that a mixture of different types of gas often makes no sense.

In the case of a single assignment = additional analog output 1:1, the signal is output **WITH** fault information.

Analog output see also: 4.8.4.8.









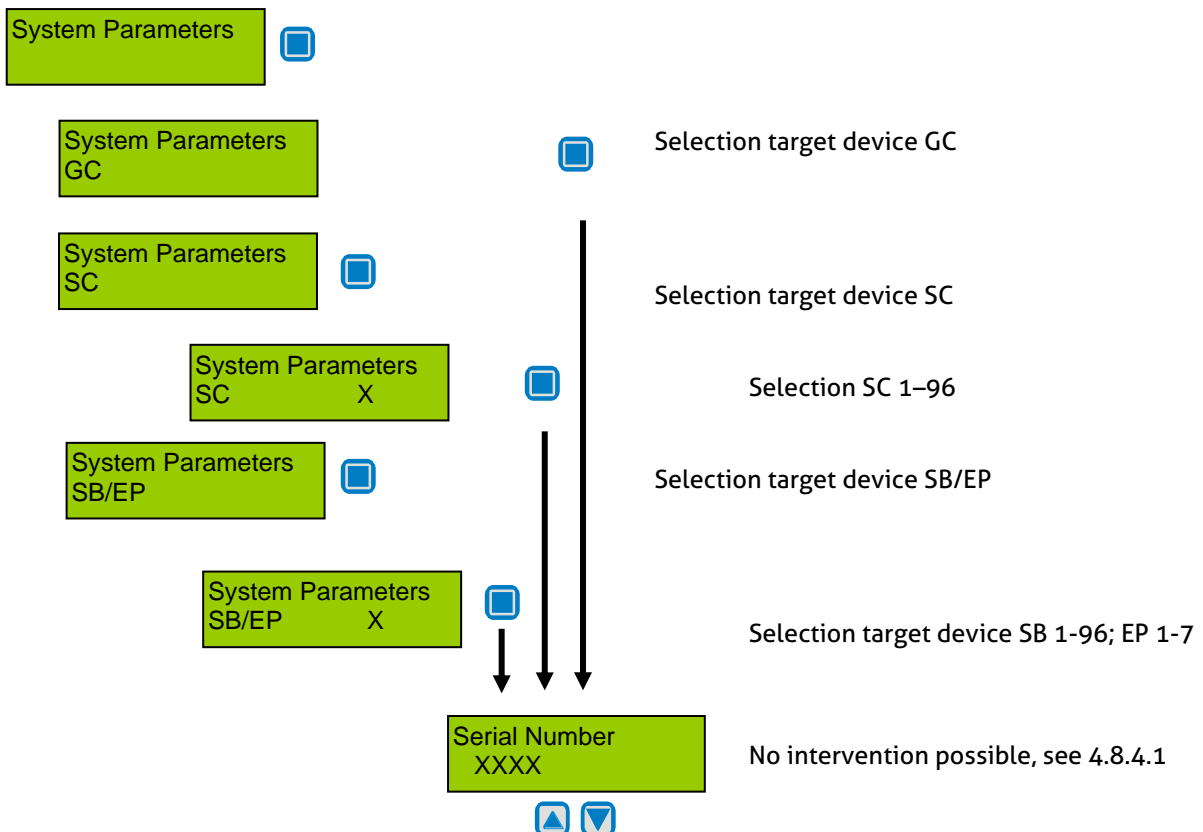









Symbol	Description	Default	Function
x y	Analog Output	x y	x = MP Signal is assigned to analog output x. (activates output control -> signal can be used) y = MP Signal is assigned to analog output y. (activates output control -> signal can be used) 0 = MP Signal isn't assigned to any analog output or no release in the System Parameters (means also: no active output control)

4.8.4 Menu System Parameters

Starting with software version 1.02.10 of the display, the DGC06 can display not only the parameters from the base board, but also those from local devices such as the EP module or SB2 and the SC2. However, the parameters from the local devices cannot be adjusted from the DGC06.

Submenu 1 Submenu 2 Submenu 3 Submenu 4



Date of Production XX.XX.XX	No intervention possible, see 4.8.4.1
 	
Maintenance Interval XXXX	Definition of the maintenance interval See 4.8.4.2
 	
AV Overlay 0 s 0 ppm	Definition of average overlay See 4.8.4.3
 	
AV Time 60s	Definition of average time See 4.8.4.3
 	
Power On Time 0s	Definition of power on time in sec. See 4.8.4.4
 	
Deadband 0 %	Definition of deadband See 4.8.4.5
 	
Activate SSM DI 0	Definition of an additional SSM relay See 4.8.4.6
 	
Special Function Standard	Selection of special function See 4.8.4.7
 	
AO Function	Selection of analog output function See 4.8.4.8
 	
R Duplication	Selection of the relay duplication See 4.8.4.9

4.8.4.1 System Information

Symbol	Description	Default	Function
XXXX	Serial Number		Serial number
XX.XX.XX	Date of Production		Date of production

4.8.4.2 Maintenance Interval

The description of the maintenance concept is shown in 4.5.

The maintenance interval of the controller is set here. If 0 is set, this function is disabled.

Symbol	Description	Default	Function
XXXX	Maintenance Interval		Entry of the interval between two services in days

4.8.4.3 Average Function

The Gas Controller calculates the arithmetic average value for each active measuring point out of 30 measurements got within the time unit defined in the menu "AV Time". This average is available in addition to the current value for alarm evaluation. The selection which value should be used for evaluation is defined separately for each alarm in the menu "Alarm Threshold X". In the average mode, the average value is indicated in the menu "Measuring Values" next to the current value.

The alarm evaluation of the control mode "Average Value" is overlaid by the current value, when the current value exceeds the alarm threshold defined in the menu "AV-Overlay". The overlay is delayed by the time factor defined in this menu. The average overlay function is only available for the gas type CO.

Average value overlay function is not available for SC.

Symbol	Description	Default	Function
120 s	AV Overlay	120 s	sec. = Delay time of average value overlay
120 ppm		120 ppm	ppm =Threshold for average overlay
900 s	AV Time	900 s	sec. = Time for calculation of the average value

Changes in the average time need a complete time cycle for new calculation!

4.8.4.4 Power On Time

Gas sensors need a running-in period, until the chemical process of the sensor reaches stable conditions. During this running-in period the current signal can lead to an unwanted triggering of a pseudo alarm. Therefore the Power On time is started at the Gas Controller after you have switched on the power supply. While this time is running out, the Gas Controller doesn't activate alarms or UPS relays. The Power On status occurs on the first line of the starting menu.

Attention: During the Power On phase the controller is in "Special Mode" and doesn't perform further functions beside the starting diagnostic procedures. A count-down Power On time in seconds is shown on the display.

Symbol	Description	Default	Function
30s	Power On time	30s	XXX = Definition of the power On time (sec.)



4.8.4.5 Deadband

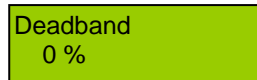

The unwanted noise of the measured value around the zero point, caused by the basic drift of the sensor, can be suppressed by activating a deadband with a range of max. 5 % to 10 % of the measuring range.

The suppression also affects the analog output, because the measured value must not assume a different display depending on the output.

When opening the calibration mode, the deadband function switches off automatically.

For PX2 the deadband can be set in the range from 0 (dead band off) to max. 5, for all other devices up to 10, The dead band on GC-06 only affects the four own analog inputs of the GC-06.

This function is not available with SC2.

4.8.4.6 Fault Activation by External DI

The collective fault output can be triggered by an external digital input in addition by using the ORing operation. Example given, the fault message of the ventilation system should be connected.

Symbol	Description	Default	Function
DI 0 BI 0	Digital Input	0	DI : 1-32 DI address via EP BI : 1-96 DI address via MSB

This menu item is only available with GC.

4.8.4.7 Special Function

The following special functions are available:

Symbol	Description	Default	Function
Standard	Function	Standard	Standard function from DGC-06
Zone function			Zone function is used in case of many local control modules.

This menu item is not available for SB/EP and SC.

The setting in the special function menu affects the distribution of control information in the DGC-06 system.

The analog outputs form the individual zones in the gas warning system.

The alarms of all DP in one zone act on the same relay.

A: Standard

The values from the 16 analog outputs are forwarded to the associated EP modules as well as to the DP addresses in 16-fold blocks, that means that each 16th DP addresses receives the information from the first analog output, etc.

Relay information is distributed 1: 1 to the corresponding addresses.

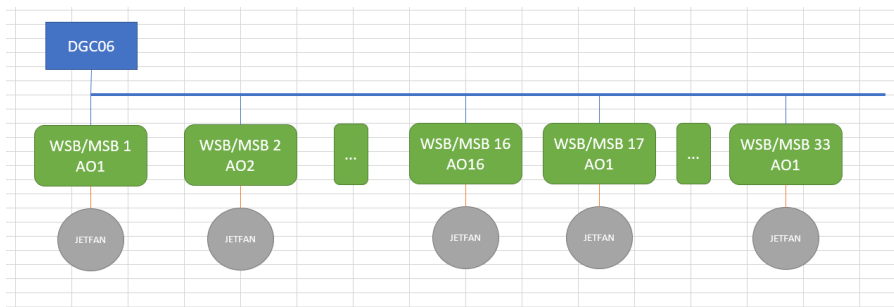

Picture: Regardless of the parameterization in the MP parameters, the analog output values are distributed in blocks of 16.

B: Zone function

Assigning the analog output to the MP parameters assigns a measurement point to a specific zone.

All DP addresses of a zone receive the value of the associated analog output.

When parameterizing MP parameters in DGC-06, the relays for Alarm 1 and 2 must be sequent.

All signal relays (SR) in a zone will trigger with the relay assigned to the first alarm in that zone, if those signal relays are used, but not assigned anywhere else.

In addition, all the local second relays in a zone which are locally set to used and remote, but not registered by any address in the fieldbus, will trigger with the relay assigned to the second alarm in that zone. This last point works only with MSB2, which is parameterized with a simple address and where the first and second relays are set to 'used' and 'remote'.

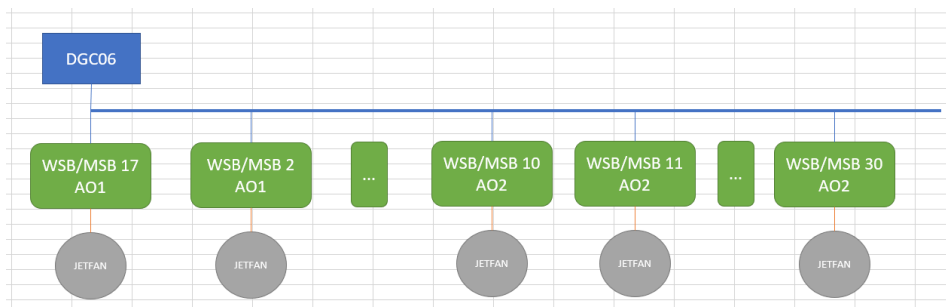

Picture: Example for parametrizing

Analog output 1 is assigned to MP 1 - 10 in the MP Parameters of the DGC-06.

Analog output 2 is assigned to MP 11 - 30 in the MP Parameters of the DGC-06.

On devices with this address, the analog output will deliver the value of the assigned analog output.

4.8.4.8 Analog Output

The Gas Controller Module as well as the EP modules 1 to 7 have got two analog outputs (AO) with 4 to 20 mA signal each. The signal of one or more measuring points can be assigned to each of the analog outputs; in this case, the signal control becomes active and the output is current monitored. The signal monitoring is self-healing and therefore mustn't be acknowledged. The assignment is done in the menu "MP Parameter" for each MP. The measuring point sends the current value signal to the analog output.

Out of the signals of all assigned measuring points the Gas Controller determines the minimum, the maximum or the average value and transmits it to the analog output. The definition, which value is transmitted, is done in the menu "Analog Output X".

To allow flexible air volume regulation of speed-controlled motors, the slope of the output signal can be adapted to the on-site conditions and varied between 10 - 100%.

If output modules are used (e.g. EP module) the variable must be set to 1, so that the controller can control the module.

Alternatively the analog inputs can control the analog outputs of the same EP module (menu in the EP module). To do so, please enter a number between 10 and 100 % on the EP module.

Symbol	Description	Default	Function
Analog Output 1	Selection of channel		Selection of the analog output 1-16
0			0 = Analog output is not used (therefore always de-activated response monitoring)
1 (EP) 10-100 %	Selection of output signal	1 (EP) 100 %	1 = Used by controller (1 to 9 not used in the central control) Selection of signal slope- permitted range 10 – 100 % 100 % gas signal control = 20 mA 10 % gas signal control = 20 mA (high sensitivity)
A	Selection of source	A	C = Source is current value A = Source is average value CF = Source is current value and additional fault message at AO AF = Source is average value and additional fault message at AO
Max.	Selection of output mode	Max.	Min. = Displays the minimum value of all assigned MP Max. = Displays the maximum value of all assigned MP Average = Displays the average value of all assigned MP

AO Function

Analog Output 1
100% A Max.

This menu item is not available with SC. The number of analog outputs for the local devices depends on the device.

4.8.4.9 Relay Multiplication

With the relay multiplication table, it is possible in the GC-06 system to assign additional relay functions to an alarm. This corresponds in the end to one multiplication of the source alarm situation per entry.

The additional relay follows the alarm status of the source but uses its own relay parameters to allow different needs of the doubled relay. So, the source relay can be configured, for example, as safety function in de-energized mode, but the doubled relay can be declared with flashing function or as horn function.

There is a maximum of 20 entries for IN relays and OUT relays. Thus, it is possible, for example, to multiply one relay to 20 others or to double max. 20 relays.

In the column IN (source), you can set the relay assigned to an alarm in the menu MP Parameter.

In the column OUT (target), you can enter the relay needed in addition.

Note:

Manual intervention in the menu Relay Status or override in external ON or OFF by external DI do not count as alarm status, so they do only affect the IN relay. If this is also desired for the OUT relay, it has to be configured separately for each OUT relay.

Number	Description	Default Status	Function
0-32	IN AR Relay	0	0 = Function off X = Relay X should be multiplied (information source).
0-96	IN SR Relay		
0-32	OUT AR Relay	0	0 = Function off X = Relay X (target) should switch together with IN relay.
0-96	OUT SR Relay		

Example 1:

3 relay contacts are needed with the same effect of relay 3, (see assignment of the relays in chapter MP Parameters.)

Entry: 1: IN AR3 OUT AR7

Entry: 2: IN AR3 OUT AR8

IN OUT
1: AR 3 AR 7.

IN OUT
2: AR 3 AR 8.

If relay 3 is activated via an alarm, relays AR3, AR7 and AR8 switch at the same time.

Example 2:

2 relay contacts each are needed from 3 relays (for ex. AR7, AR8, AR9).

Entry: 1: IN AR7 OUT AR12 (Relay 12 switches at the same time with relay 7)

Entry: 2: IN AR8 OUT AR13 (Relay 13 switches at the same time with relay 8)

Entry: 3: IN AR9 OUT AR14 (Relay 14 switches at the same time with relay 9)

IN OUT
1: AR 7 AR 12.

IN OUT
2: AR 8 AR 13.

IN OUT
3: AR 9 AR 14.

This means that relay AR7 switches with AR12;
AR8 with AR13; AR9 with AR14.

The two examples can be mixed up, too.

This menu item is not available for SC and SB/EP.

4.8.5 Operating Data

No intervention possible in the Operating Data. Viewing the operating data helps with troubleshooting.

Submenu 1 Submenu 2 Submenu 3 Submenu 4

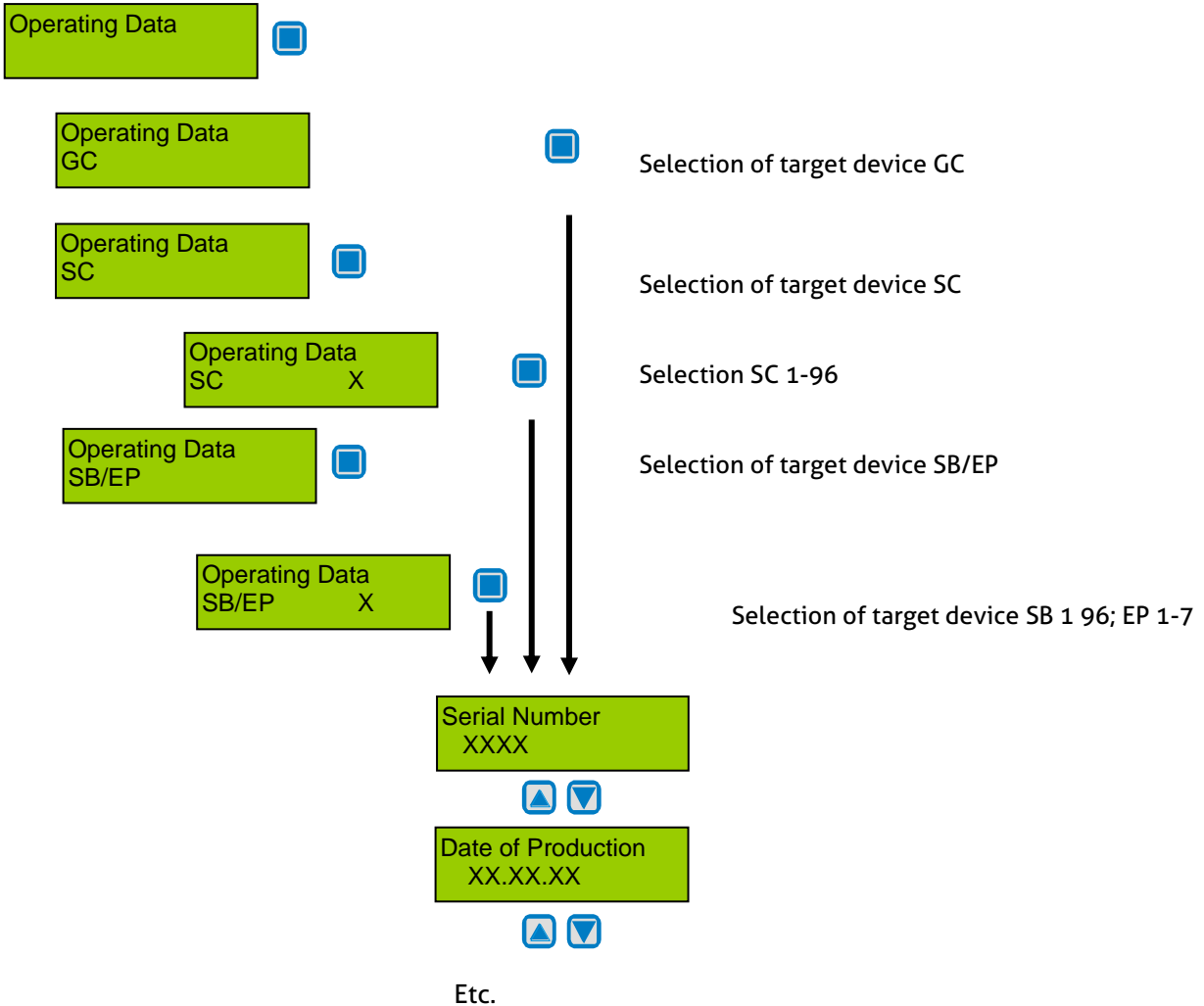

4.8.5.1 Operating Data of a Sensor Cartridge

Reading the operating data from a SC at the GC can take a few seconds, as it is queried via the local devices.

Headline	Value	Description
Software Version	XXXXXX	Software Version
Operating Days	XXXX days	Days of operation since the SC has been switched on for the first time
Gas Conc. Counter	XXXX 10%MR/day	Gas concentration counter Counts the gas concentration on the SC in the unit 10 % of the measuring range per day.
Operating Days Expected	XXXX days	Expected service life of the sensor element, depending on the previous gas concentration and calibrations
Min. Temperature	XX °C	Minimum temperature ever registered by SC
Max. Temperature	XX °C	Maximum temperature ever registered by SC
Last Tool No.	XXXX	Tool number of the tool the calibration was last carried out with
Analog Output 1 Offset	XXXX	Shows the currently set offset of the analog output at the MC2, also available for SC because of compatibility
Calib. Number	XXX	Number of calibrations on the SC, factory calibration is not included
Zero Gain	XXXX XXXX	Currently set zero offset and gain factor on the SC
Sensitivity	XXX %	Sensitivity of the sensor element during the last calibration
Maintenance Days Last	XXXX	Remaining days until maintenance during the last calibration
Operating Days Last	XXXX	Operating days during the last calibration
Maintenance Days Currently	XXXX	Current number of remaining days until next maintenance
Max. Current Value	XXXX	Maximum current value measured, with unit

4.8.5.2 Operating Data of a Sensor Board / EP-Module

Headline	Value	Description
Serial Number	XXXX	Serial number
Date of production	XX.XX.XX	Date of production
Operating Days	XXXX days	Days of operation since the SB/EP has been switched on for the first time
Min. Temperature	XX °C	Minimum temperature ever registered by SB/EP
Max. Temperature	XX °C	Maximum temperature ever registered by SB/EP
Last Tool No.	XXXX	Tool number of the tool the calibration was last carried out with
Analog Output 1 Offset	XXXX	Shows the currently set offset of the first analog output at the SB/EP
Analog Output 2 Offset	XXXX	Shows the currently set offset of the second analog output at the SB/EP, also available for SB because of compatibility
MP X	/	Selection of the operating data for maximum four analog inputs (EP)

MP X

Headline	Value	Description
Calib. Number	XXX	Number of calibrations on the AI X, factory calibration is not included
Zero Gain	XXXX XXXX	Currently set zero offset and gain factor on the AI X
Sensitivity	XXX %	Sensitivity of the AI during the last calibration, related to the connected device
Maintenance Days Last	XXXX	Remaining days until maintenance during the last calibration
Operating Days Last	XXXX	Operating days during the last calibration
Maintenance Days Currently	XXXX	Current number of remaining days until next maintenance
Max. Current Value	XXXX	Maximum current value measured, with unit

4.8.5.3 Operating Data of a Gas Controller

The operating data of the Gas Controller are the same as for SB/EP.

4.8.6 Test Function of the Alarm and Signal Relays

This function is only available in special mode.

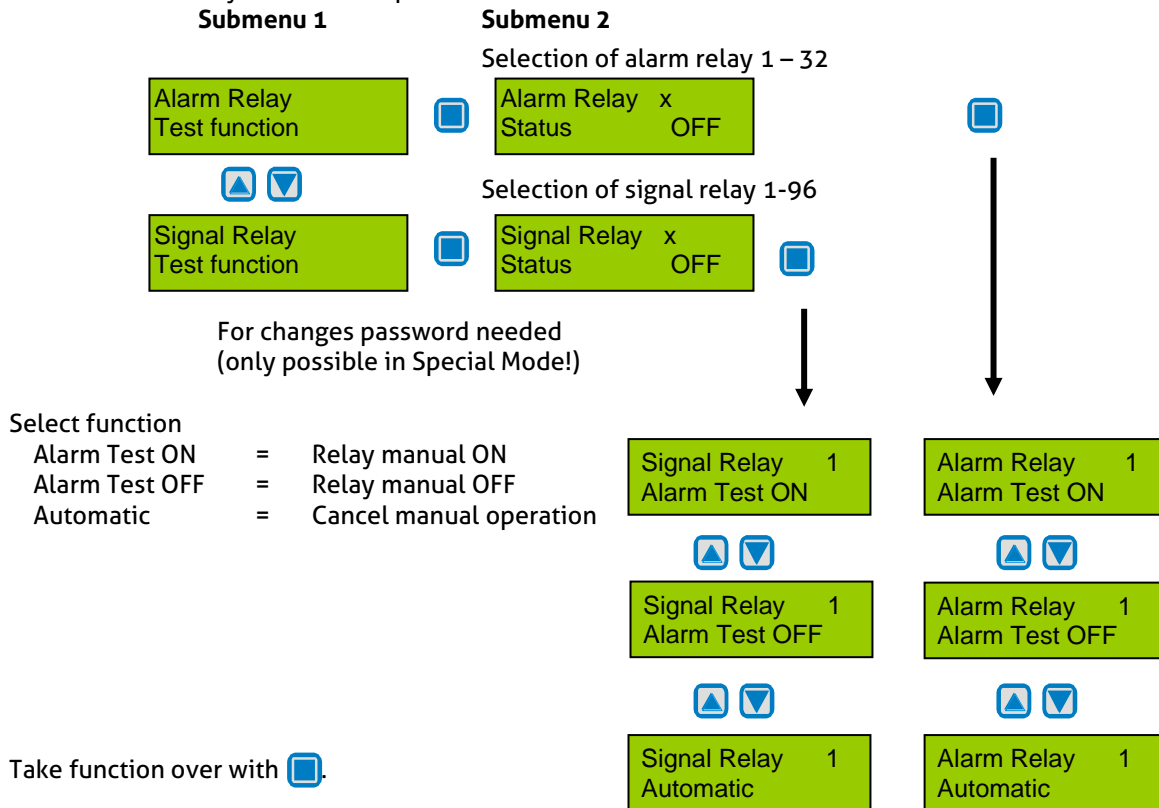

This function is for testing only the relays with the local setting 'Remote'. The relays with local control must be tested locally with a tool. When Alarm Test ON is set, the relay switches to alarm state. Depending on the parameterization it can cause different reactions. For example, the flashing mode will cause the relay to start flashing, and so on.

The external operation of the relays via an assigned digital input has priority to the manual test function in this menu item.

Symbol	Description	Function
AR Status	Relay Nr. X	X = 1 – 32 Select alarm relay
SR Status	Relay Nr. X	X = 1 – 96 Select signal relay
Status OFF	Relay Status	Status OFF = Relay OFF (no gas alarm) Status ON = Relay ON (gas alarm)
Alarm test ON	Manual Setting	Alarm Test OFF = Relay manual OFF Alarm Test ON = Relay manual ON Automatic = Resets the relay in automatic mode

4.8.7 Test Function of the Analog Outputs

This feature is only available in Special Mode.

With the test function you can enter the value (in mA) that should be physically output.

The test function via the controller can only be applied when the analog outputs are overridden (configuration 1 of analog outputs in the system parameters of the associated device, see 4.8.4.8)

If an analog output is not assigned anywhere, it is displayed as inactive and cannot be tested.

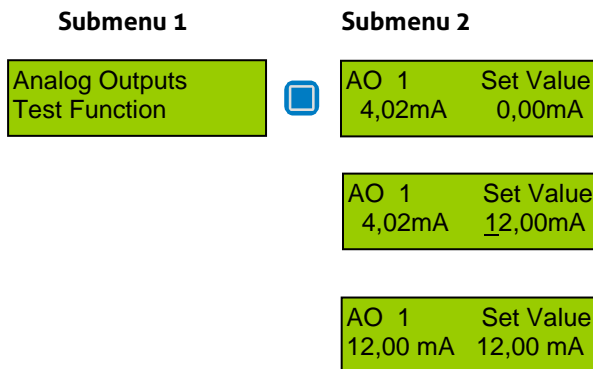

On the left, the current set point of the AO is shown. On the right, there is the default value entered by the operator.

After confirming the AO accepts the predetermined value and outputs it physically. As the current set point is transmitted again and again, the confirmation appears in the display at the left.

The default value is output until the test function is exited with ESC or via the idle time.

5 Notes and General Information

It is important to read this user manual carefully in order to understand the information and instructions. The PolyGard®2 GC-06 gas monitoring, control and alarm system may only be used for applications in accordance to the intended use. The appropriate operating and maintenance instructions and recommendations must be followed.

Due to permanent product developments, MSR reserves the right to change specifications without notice. The information contained herein is based on data considered to be accurate. However, no guarantee or warranty is expressed or implied concerning the accuracy of these data.

5.1 Intended Product Application

The PolyGard®2 GC-06 is designed and manufactured for controlling, for saving energy and keeping OSHA air quality in commercial buildings and manufacturing plants.

5.2 Installer's Responsibilities

It is the installer's responsibility to ensure that all PolyGard®2 GC-06 are installed in compliance with all national and local regulations and OSHA requirements. All installation shall be executed only by technicians familiar with proper installation techniques and with codes, standards and proper safety procedures for control installations and the latest edition of the National Electrical Code (ANSI/NFPA70).

The equipotential bonding required (also e.g. secondary potential to earth) or grounding measures must be carried out in accordance with the respective project requirements. It is important to ensure that no ground loops are formed to avoid unwanted interference in the electronic measuring equipment.

It is also essential to follow strictly all instructions as provided in the user manual.

5.3 Maintenance

We recommend checking the PolyGard®2 GC-06 system regularly. Due to regular maintenance differences in efficiency can easily be corrected. Re-calibration and replacement of parts can be realised on site by a qualified technician with the appropriate tools. Alternatively, the removable Gas Controller can be returned to MSR-Electronic GmbH for services.

5.4 Limited Warranty

MSR warrants the PolyGard®2 GC-06 against defects in material or workmanship for a period of one (1) year beginning from the date of shipment. Should any evidence of defects in material or workmanship occur during the warranty period, MSR will repair or replace the product at their own discretion, without charge.

This warranty does not apply to units that have been altered, had attempted repair, or been subjected to abuse, accidental or otherwise. The above warranty is in lieu of all other explicit warranties, obligations or liabilities.

This warranty extends only to the PolyGard®2 GC-06. MSR-Electronic GmbH shall not be liable for any incidental or consequential damages arising out of or related to the use of the PolyGard®2 GC-06.